

<b>NORDYNE</b> ENGINEERING SPECIFICATION (SYSA Friendly Rev. 2)	SPEC. NO. <b>1011727</b> REV. <b>0</b>			REASON FOR REV.	
	DATE	<b>10/27/2016</b>	SHEET <b>1</b> OF <b>1</b>	NEW PART	<b>X</b>
	S'SEDE'S		See literature with same #	ADDED PART	
	DATED		See vendor print w/ same #	CHANGE	

DESCRIPTION:  
LABEL, WIRING DIAGRAM, 2-SPEED MOTOR, 208-240 VOLTS, R7TQ-090/120

EXTENDED DESCRIPTION:  
MATERIAL: Pressue sensitive adhesive, per Nortek Spec #800166-  
COLOR: Black ink on White paper  
SIZE: 11.0" X 17.0" including 0.125" perimeter border  
PAGES: 2

NOTE: When printed in house, print on 11.0" x 17.0" sheet following all specifications noted

REV.	ECM	ENG. APPROVAL / DATE	TOLERANCES (UNLESS OTHERWISE SPECIFIED)	
-	402468	Richard Blasko / 10/27/2016	Fractions(±)	1/32
			Hole spacing(±)	
			Decimals(±)	0.031
			Hole Location(±)	

**ANY CONSTRUCTION CHANGE IN THIS PART FROM THE APPROVED SAMPLE PROVIDED NORDYNE ENGINEERING (ON WHICH THIS SPECIFICATION IS BASED) MUST RECEIVE WRITTEN ENGINEERING APPROVAL PRIOR TO SUPPLYING SUCH REVISED PARTS**

# DSI BOARD LED'S

REFER TO DRAWING # 1011991 FOR STANDARD PLUG & ECONOMIZER PLUG CONNECTION

LED STATE		
COLOR	CODE	
GREEN	STEADY ON	NORMAL OPERATION NO CALL FOR HEAT
GREEN	FAST FLASH	NORMAL OPERATION CALL FOR HEAT
GREEN	1 FLASH	IN LOCKOUT FROM FIELD IGNITIONS OR FLAME LOSSES
GREEN	2 FLASHES	PRESSURE SWITCH DOES NOT CLOSE WITHIN 30 SECONDS OF VENTER ENERGIZED
GREEN	3 FLASHES	LIMIT SWITCH OPEN
GREEN	4 FLASHES	PRESSURE SWITCH IS CLOSED BEFORE VENTER IS ENERGIZED
GREEN	STEADY OFF	INTERNAL CONTROL FAULT OR NO POWER
YELLOW	STEADY ON	FLAME SENSED
YELLOW	SLOW FLASH	WEAK FLAME
YELLOW	FAST FLASH	UNDESIRED FLAME (VALVE OPEN & NO CALL FOR HEAT)

### NOTES

1. DISCONNECT ALL POWER BEFORE SERVICING.
2. CAUTION: IF ANY OF THE ORIGINAL WIRE AS SUPPLIED WITH THE APPLIANCE MUST BE REPLACED, IT MUST BE REPLACED WITH WIRING MATERIAL HAVING A TEMPERATURE RATING OF AT LEAST 105 DEGREES C.
3. LINE AND BLOWER MOTOR BRANCH CIRCUIT WIRE SHOULD BE OF A SIZE TO PREVENT VOLTAGE DROP BEYOND FIVE PERCENT OF SUPPLY LINE VOLTAGE.
4. SEE RATING PLATE LABEL FOR MCA, TO DETERMINE LINE FEED COPPER WIRE SIZE. LINE FEEDS CONNECT TO THE LOCKABLE DISCONNECT OR DISTRIBUTION BLOCKS.
5. USE #18 GA. WIRE FOR 24 VOLT CONTROL WIRING ON UNIT.
6. WHEN PROVIDING OR REPLACING FUSES IN THE FUSIBLE DISCONNECT SWITCH USE DUAL ELEMENTS TIME DELAY FUSES AND SIZE ACCORDING TO 1.25 TIMES THE MAXIMUM TOTAL INPUT AMPS.
7. ALL MOTORS MARKED IOL HAVE INTERNAL LINE BREAK.
8. FUSIBLE DISCONNECT IS FIELD FURNISHED OR AVAILABLE FROM FACTORY AS AN OPTION.
9. THE LINE SIDE OF THE DISCONNECT SWITCH MUST BE CONNECTED TO THE INCOMING POWER SUPPLY SUCH THAT THE VOLTAGE BETWEEN L1 AND GROUND IS THE GREATER VALUE.

### FIELD CONTROL WIRING

TOTAL WIRE LENGTH	MINIMUM RECOMMENDED WIRE SIZE
150 FEET	#18 GA.
250 FEET	#16 GA.
350 FEET	#14 GA.

### WIRING CODE

- BLACK - BK
- BROWN - BR
- RED - RD
- ORANGE - OR
- YELLOW - YE
- GREEN - GN
- BLUE - BL
- VIOLET - VI
- WHITE - WH
- GRAY - GY

————— FACTORY WIRING  
 - - - - - FIELD WIRING

□ TERMINAL BLOCK -- UNIT PANEL (HIGH VOLTAGE SECTION)  
 ◇ TERMINAL BLOCK -- UNIT PANEL (LOW VOLTAGE SECTION)

□	L1	◇	L1
	L2		L3
	L3		3

1  
2  
3  
4  
5  
6  
7  
8  
9  
10  
11  
12  
13  
14  
15  
16  
17  
18  
19  
20  
21  
22  
23  
24  
25  
26  
27  
28  
29  
30  
31  
32  
33  
34  
35  
36  
37  
38  
39  
40  
41  
42  
43  
44  
45  
46  
47  
48  
49

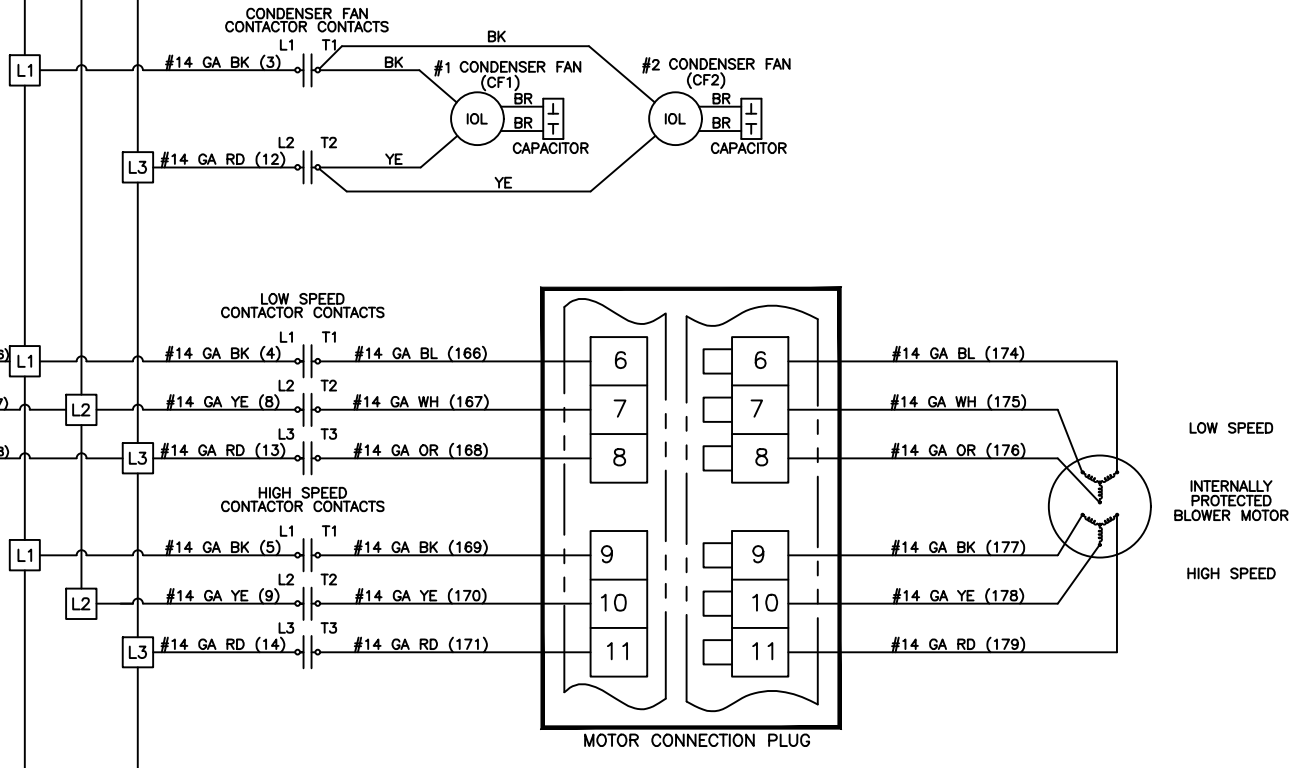
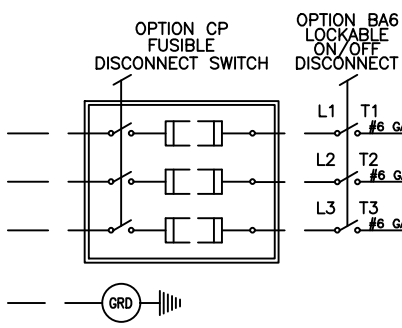
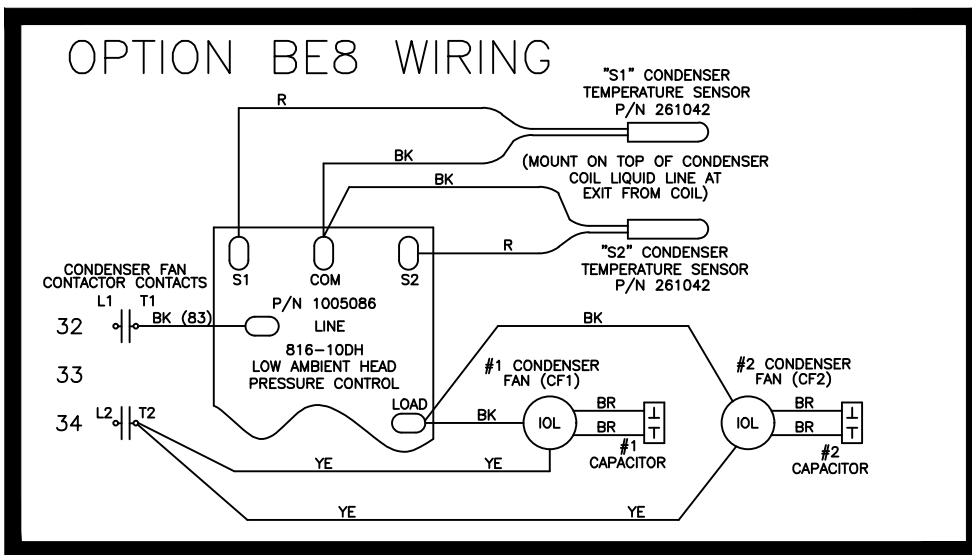
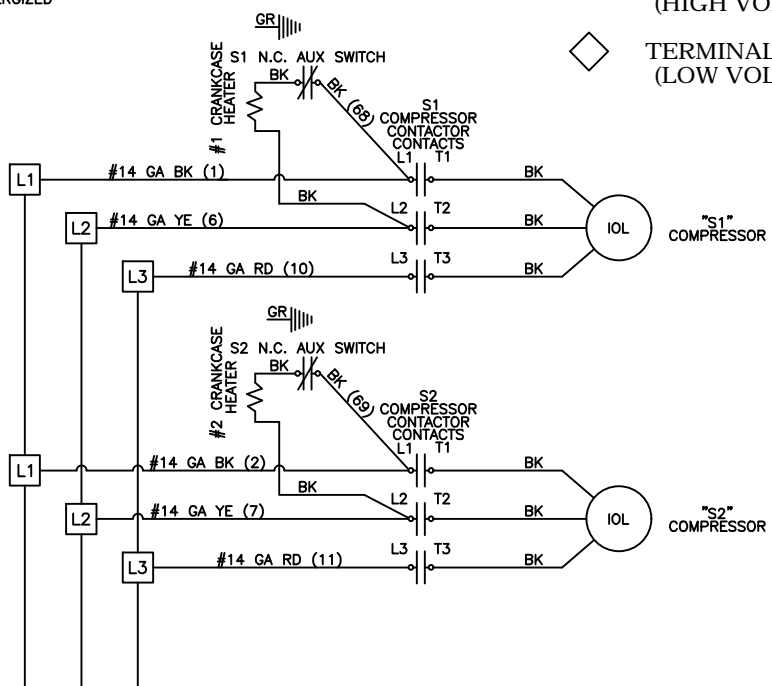
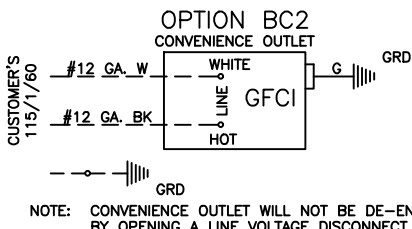

TRANSFORMER NOTE:

FOR 208V OPERATION REMOVE WIRE FROM 230V TAP AND PLACE ON 208V TAP.

