

P7TQ-090/120: AK7-AMS6 SHT. #1

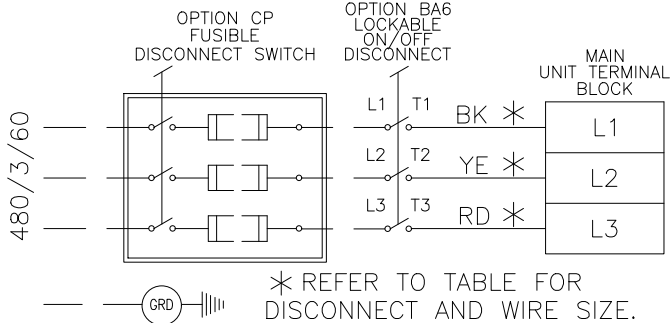

* REFER TO TABLE FOR DISCONNECT AND WIRE SIZE.

DISCONNECT & WIRE SIZES			
VOLTAGE	ELECTRIC SIZE (kW)	WIRE GA	DISCONNECT SIZE
208-230/3/60	9	6	60
	18	6	60
	30	2	100
460/3/60	9	6	60
	18	6	60
	30	6	60
575/3/60	10	6	60
	20	6	60
	30	6	60
	40	6	60

- NOTES**
1. DISCONNECT ALL POWER BEFORE SERVICING.
 2. CAUTION: IF ANY OF THE ORIGINAL WIRE AS SUPPLIED WITH THE APPLIANCE MUST BE REPLACED, IT MUST BE REPLACED WITH WIRING MATERIAL HAVING A TEMPERATURE RATING OF AT LEAST 105 DEGREES C.
 3. LINE AND BLOWER MOTOR BRANCH CIRCUIT WIRE SHOULD BE OF A SIZE TO PREVENT VOLTAGE DROP BEYOND FIVE PERCENT OF SUPPLY LINE VOLTAGE.
 4. SEE RATING PLATE LABEL FOR MCA, TO DETERMINE LINE FEED COPPER WIRE SIZE. LINE FEEDS CONNECT TO THE LOCKABLE DISCONNECT OR DISTRIBUTION BLOCKS.
 5. USE #18 GA. WIRE FOR 24 VOLT CONTROL WIRING ON UNIT.
 6. WHEN PROVIDING OR REPLACING FUSES IN THE FUSIBLE DISCONNECT SWITCH USE DUAL ELEMENTS TIME DELAY FUSES AND SIZE ACCORDING TO 1.25 TIMES THE MAXIMUM TOTAL INPUT AMPS.
 7. ALL MOTORS MARKED IOL HAVE INTERNAL LINE BREAK.
 8. FUSIBLE DISCONNECT IS FIELD FURNISHED OR AVAILABLE FROM FACTORY AS AN OPTION.
 9. THE LINE SIDE OF THE DISCONNECT SWITCH MUST BE CONNECTED TO THE INCOMING POWER SUPPLY SUCH THAT THE VOLTAGE BETWEEN L1 AND GROUND IS THE GREATER VALUE.
 10. ALL 24 VAC LOW VOLTAGE CONNECTIONS TO UNIT MUST BE CLASS 2.

WIRING CODE

- BLACK - BK
- BROWN - BR
- RED - RD
- ORANGE - OR
- YELLOW - YE
- GREEN - GN
- BLUE - BL
- VIOLET - VI
- WHITE - WH
- GRAY - GY

FIELD CONTROL WIRING

TOTAL WIRE LENGTH	MINIMUM RECOMMENDED WIRE SIZE
150 FEET	#18 GA.
250 FEET	#16 GA.
350 FEET	#14 GA.

— FACTORY WIRING
- - - FIELD WIRING

□ TERMINAL BLOCK -- UNIT PANEL (HIGH VOLTAGE SECTION)

◇ TERMINAL BLOCK -- UNIT PANEL (LOW VOLTAGE SECTION)

□ L1
□ L2
□ L3

◇ L1
◇ L2
◇ L3

- 1
- 2
- 3
- 4
- 5
- 6
- 7
- 8
- 8
- 10
- 16
- 20
- 21
- 22
- 36
- 37
- 38
- 39
- 40
- 41
- 46
- 48
- 50
- 51
- 52
- 53
- 54
- 72

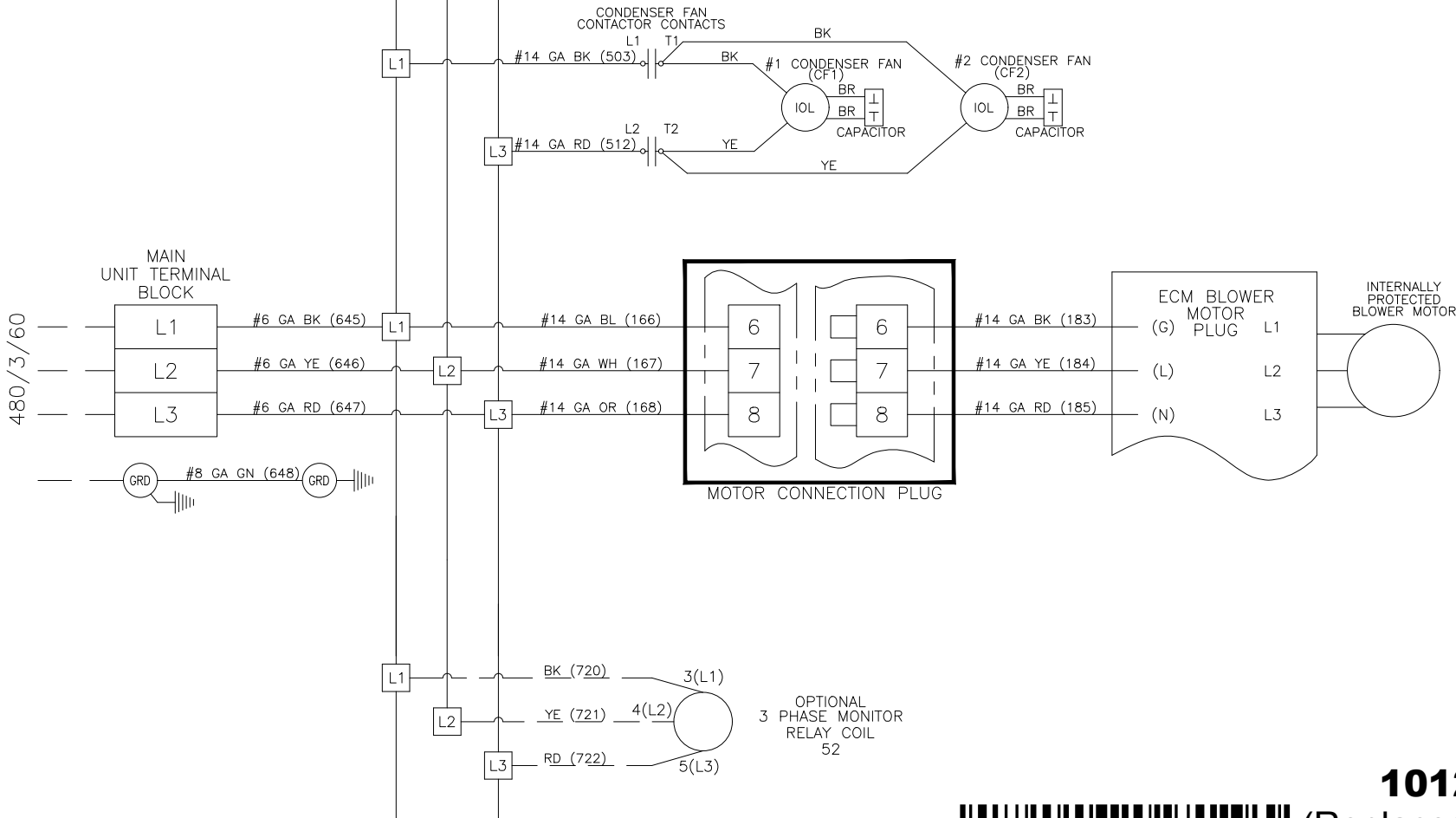
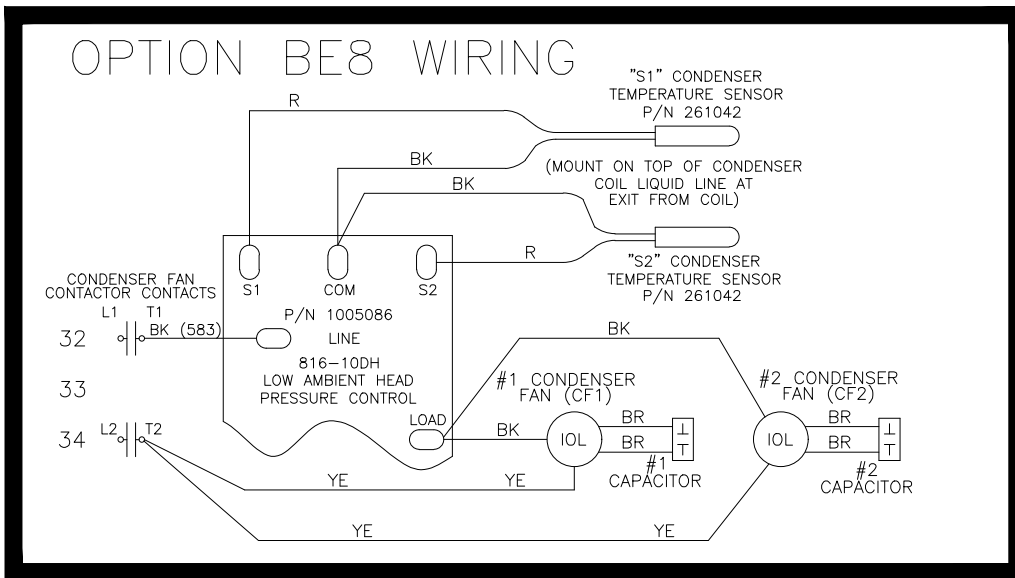
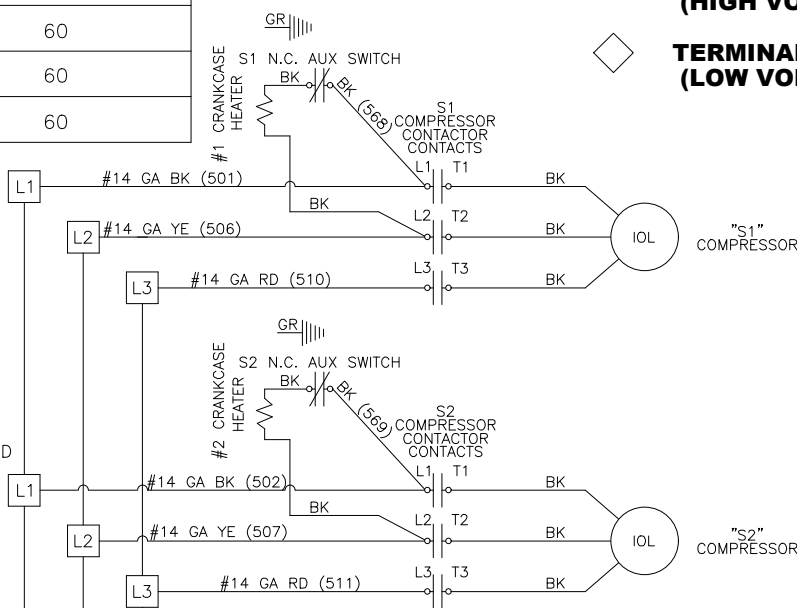
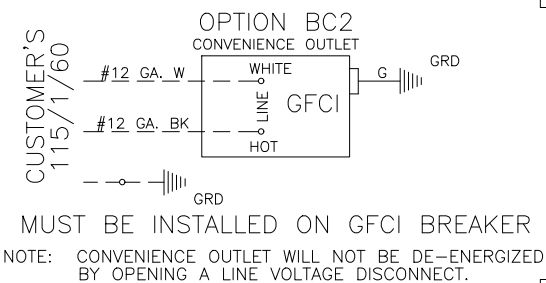

1012122C

(Replaces 1012122B)

04/18



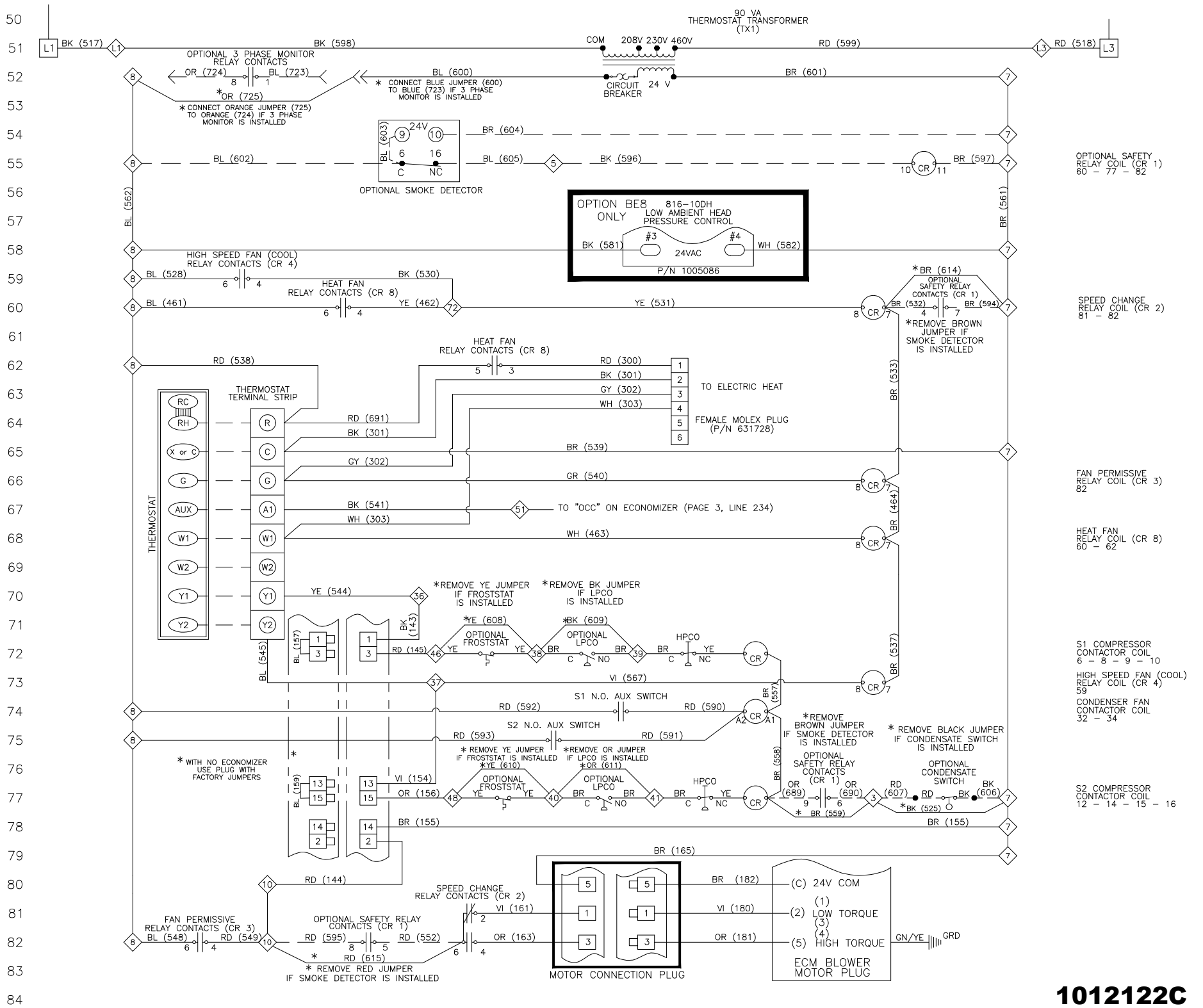

1012122C
 (Replaces 1012122B)
 04/18

