

R7DA Series

6, 7 ½, 10 and 12 ½ Ton DOAS Packaged Gas/Electric Units

**>4.0 ISMRE Commercial System
81% Steady State Efficiency**

Standard Features

- Fits Pre-Existing Curbs
- High-Efficiency
- Low Refrigerant Requirement
- Foam Panel Wall Construction
- Hinged Access Doors
- Compatible Utility Connections



FEATURES and BENEFITS

Backward Incline Plenum Fan with Direct Drive ECM

- Vibration isolation.
- Supply fan CFM measuring ports.

Modulated Air Colled DX

- >4.0 ISMRE rated system.
- 10-100% capacity control.
- Rust proof double sloped drain pan.
- 4 row evaporator coil with TXV.
- Micro channel aluminum condenser coil.
- High pressure cut-off safety switch.
- Crank case heaters.
- Liquid line and filter drier & service ports.
- Low noise condenser fan & motor.

Indirect Fired Natural Gas Heat

- 81% steady state thermal efficiency.
- 6:1 modulation (17-100%).
- Constant efficiency combustion air control.
- Stainless steel Heat Exchanger.
- Low noise condenser fan & motor.

1" Foam Panel Cabinet Construction

- 1" all wetted areas, bottom pan and roof.
- > 6.4 R insulation value.
- Full perimeter base rail with fork lift holes
- Galvanized steel with Gloss 90 finish.
- Utilizes industry standard dimensions.
- Hinged door access with hold down rods.

Electrical & DDC Controls

- MUA, space temp control & VAV sequence.
- Monitored alarms & diagnostics.
- Fans speed control.
- Inlet damper control sequences.
- Ice cube relays & terminal strip wiring.

OPTIONAL FEATURES

Power

- 208/230/460V 3Phase 60Hz
- Factory installed rotor disconnect with lockout
- Field install disconnnet, fusible, outdoor, UL

DX Cooling & Reheat Options

- Hot gas reheat coil & control
- Condensate overflow float switch
- Evaporator coil frostat - Low temperature < 33°F
- Electrofin® coil coating, evap/cond
- Low ambient DX system operation > 32°F
- Mesh condenser hail guard

Heat (Gas)

- Heat sizes (MBH) - 100, 166, 200, 225
- Propane conversion kit
 - 5:1 modulated control
- High altitude kit gas (natural gas)
- 409 stainless steel heat exchanger
- Flue extension kit

Supply Speed Control

- High-low volume control
- 0-10V input signal for fan control
- BMS control through BacNet point
- Fan RPM by duct stactic pressure sensor (0-2.5" w.c.)
- RPM by building static pressure sensor (+0.5" w.c.)
- 2-speed CO2 control (high/low)
- RPM by supply fan CFM
- Occupied/unoccupied speed
- Constant volumen - summer/winter

Intake & Damper Options

- Outdoor air intake hood
- 4" MERV 8 filters - unit
- 4" MERV 13 filters - unit
- 100% OA damper/no return - AR8
- OA & RA dampter - modulating
- Dampter control
 - High-low volume control
 - 0-10V input signal for fan control
 - BMS control through BacNet point
 - Fan RPM by duct stactic pressure sensor (0-2.5" w.c.)
 - RPM by building static pressure sensor (+0.5" w.c.)
 - 2-speed CO2 control (high/low)

Unit Control Options

- Space temperature control w/ thermostat
- Makeup air control sequence
- Variable volume & temperature control
- DDC direct space temperature & humidity control
- Thermostat - BacNet enabled
- Thermostat - Lon enabled
- Supply fan CFM monitoring
- Space mounted CO2 sensor
- Smoke detector (duct mounted)
- Dirty filter indication
- Phase loss monitor
- BacNet communication
- Handed held unit display
- Wall mounted unit display
- Convenience outlet (requires 110V supply)
- Flue extension kit - std eff single furnance

Curbs & Curb Accessories

- 18" height, vertical discharge, no ERV, exposed external insulation
- Hurricane rated hold down clips (186 MPH)

Miscellaneous Options

- Extra set: 4" MERV 8 filters
- Extra set: 4" MERV 13 filters
- 10 business day quick ship
- 5-year compressor warranty
- 5-year gas heat exchanger warranty
- 10-year gas heat exchanger warranty
- 2-year all parts warranty

Model R7DA	072	090	120	150
Nominal Capacity (Ton)	6	7.5	10	12.5
Unit CFM Range	840-1800	1050-2250	1400-3000	1750-3750
ISMRE (lb/(kW.hr))	>4	>4	>4	>4
Weight (lb)	1145	1182	1225	
Unit Filters	4" MERV 8 (#211128)	4" MERV 8 (#211126)	4" MERV 8 (#211126)	4" MERV 8 (#211126)
	4" MERV 13 (#256666)	4" MERV 13 (#256664)	4" MERV 13 (#256664)	4" MERV 13 (#256664)
	16"x25" (qty 2)	16"x16" (qty 4)	16"x16" (qty 4)	16"x16" (qty 4)
Fan System				
Supply Blower Type	Backward Curve Centrifugal Blower			
Fan Motor Type	Electronically Communicated Motor			
Control Type	Variable Speed by Control System			
DX System				
Refrigerant	R410A			
Evaporator Coil	4Row / 14 FPI			
Condenser Coil	Aluminum Micro-Channel			
Compressor(s)	Q (1) Digital Scroll	Q (1) Digital Scroll	Q (1) Digital Scroll	Q (2) Digital Scroll & Fixed Capacity Scroll
Condenser Fan Motors QTY/HP	1/4 HP, qty 2	1/3 HP, qty 2	1/3 HP, qty 2	1/3 HP, qty 2
Hot Gas Reheat	"1 Row / 12 FPI 3 way control valve"	"1 Row / 12 FPI 3 way control valve"	"1 Row / 12 FPI 3 way control valve"	"1 Row / 12 FPI 3 way control valve"
Gas Heating System				
Fuel Type	"Natural gas (propane conversion kit)"	"Natural gas (propane conversion kit)"	"Natural gas (propane conversion kit)"	"Natural gas (propane conversion kit)"
Input Capacity (MBH)	"100 166"	"166 200 225"	"166 200 225"	"166 200 225"
Efficiency	81%	81%	81%	81%
Minimum and Maximum Temperature Rise	30-90°F	30-90°F	30-90°F	30-90°F
Modulation Range	Nat. 6:1 / Propane 5:1	Nat. 6:1 / Propane 5:1	Nat. 6:1 / Propane 5:1	Nat. 6:1 / Propane 5:1
Electrical System				
Unit Power	208-230V / 460V (60Hz)			
Minimum Current Ampicity (MCA) 208-230V/460V	36/18	42.5/22.7	53/30.5	68.6/35.6
Maximum Over Current Protection (MOP)	50/25	60/35	80/45	90/45
Control System	DDC with Display			
Control Sequence	Thermostat Interface, Make-up Air, Variable Air Volume (VAV), DDC Space Temperature Control			

R7DA COMPONENT LOCATIONS

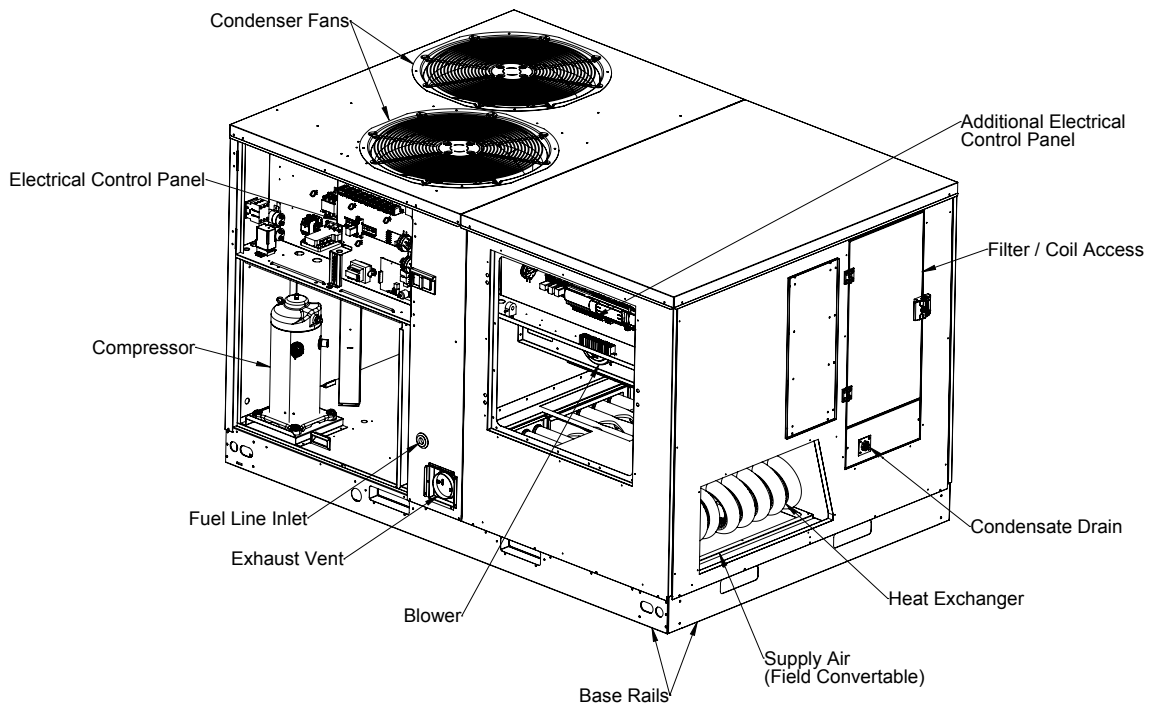

R7DA – PHYSICAL DATA

Unit Clearance: 24" Condenser Coil Airflow (A to D to C), 24" Door Access A-B-C & D)

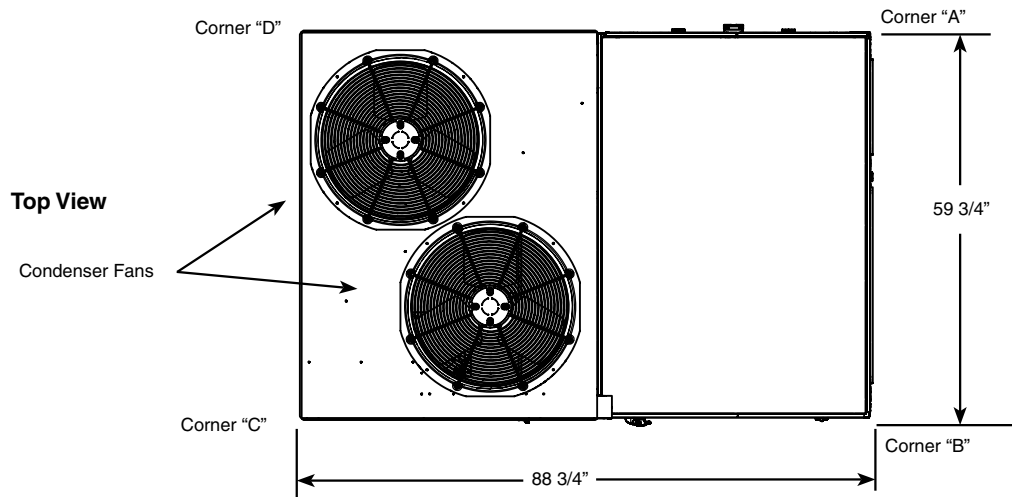

CENTER OF GRAVITY & UNIT SHIPPING WEIGHTS

MODEL NUMBER	UNIT WEIGHT		SHIPPING WEIGHT		CENTER OF GRAVITY INCHES (MM)		CORNER WEIGHTS								UNIT HEIGHT	
					A	B	A		B		C		D		HORIZONTAL DUCT APPLICATIONS	VERTICAL DUCT APPLICATIONS
	LBS.	KG.	LBS.	KG.	LBS.	KG.	LBS.	KG.	LBS.	KG.	LBS.	KG.	LBS.	KG.		
R7DA072	1145	519	1267	575	49" (1245)	27" (686)	284	129	347	157	283	128	232	105	54"	48.5"
R7DA090	1182	536	1304	591	50" (1270)	28" (711)	310	141	354	161	276	125	242	110	54"	48.5"
R7DA120	1225	556	1344	611	47" (1194)	26" (660)	280	127	367	166	328	149	251	114	54"	48.5"
R7DA150	1395	633	1514	687	43" (1092)	24" (610)	258	117	416	189	445	202	276	125	64"	58.5"

**Baseraills are not intended to be removed. Information provided is total unit height for horizontal duct applications or height dimension added to selected roof curb height for vertical duct applications.

‡ Unit weight without packaging or field installed accessories.

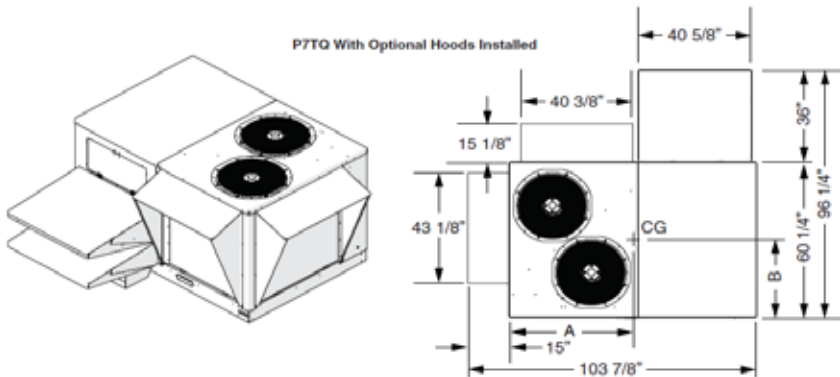
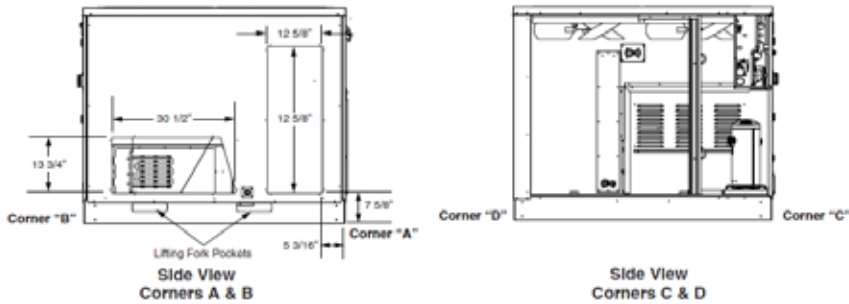

6 and 7.5 Ton Blower

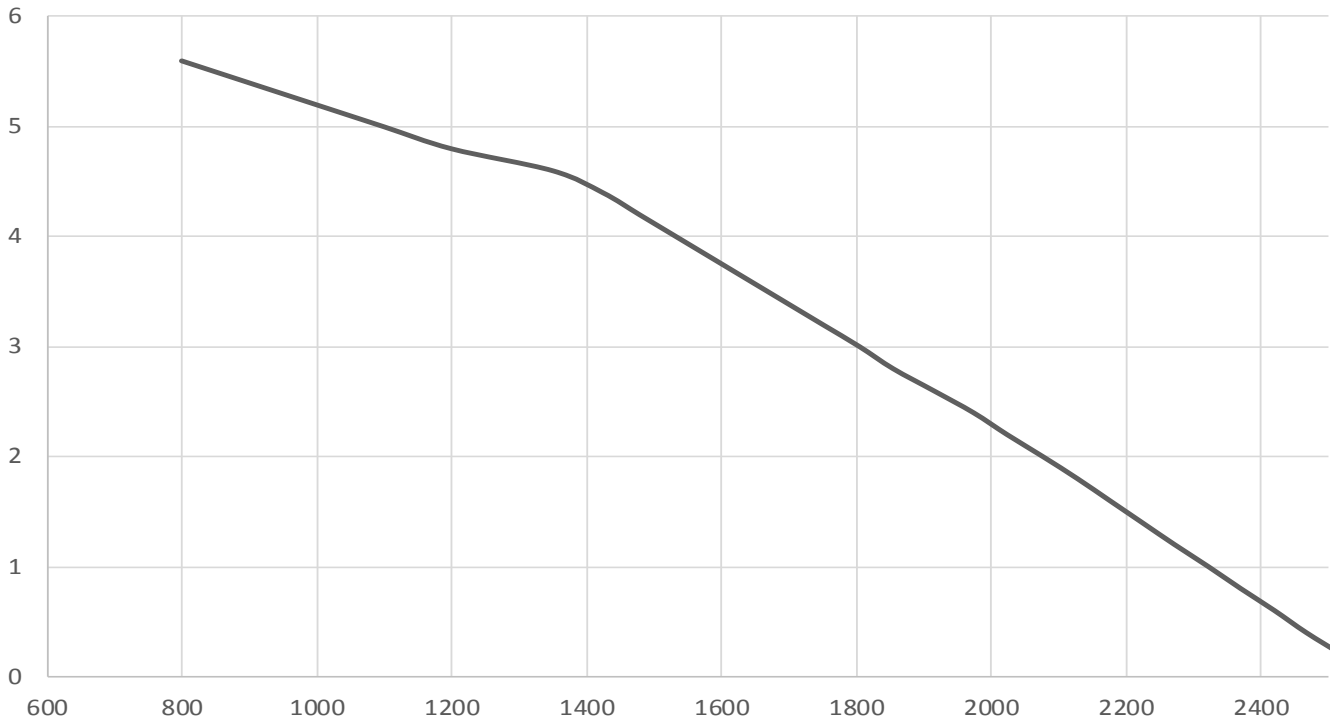

Air flow test with inlet duct, dry coil				
Inlet air temp (°F)	Blower PWM %	External SP (in wc)	Air Flow Rate (SCFM)	Blower Power (W)
69.8	100	0.1	2548	1585
70.2	100	0.2	2519	1593
70.1	100	0.4	2466	1622
69.7	100	0.6	2419	1646
69.9	100	0.8	2369	1675
70	100	1	2321	1703
70.1	100	1.2	2271	1726
70.2	100	1.4	2223	1744
70.3	100	1.6	2175	1770
70.2	100	1.8	2127	1798
70.1	100	2	2076	1821
70	100	2.2	2023	1842
69.9	100	2.4	1973	1861
69.8	100	2.6	1914	1874
69.8	100	2.8	1854	1895
		3	1804	
		3.2	1750	
		3.4	1696	
		3.6	1641	
		3.8	1587	
		4	1533	
		4.2	1479	
		4.4	1424	
		4.6	1350	
		4.8	1200	
		5	1100	
		5.2	1000	
		5.4	900	
		5.6	800	

10 Ton Blower

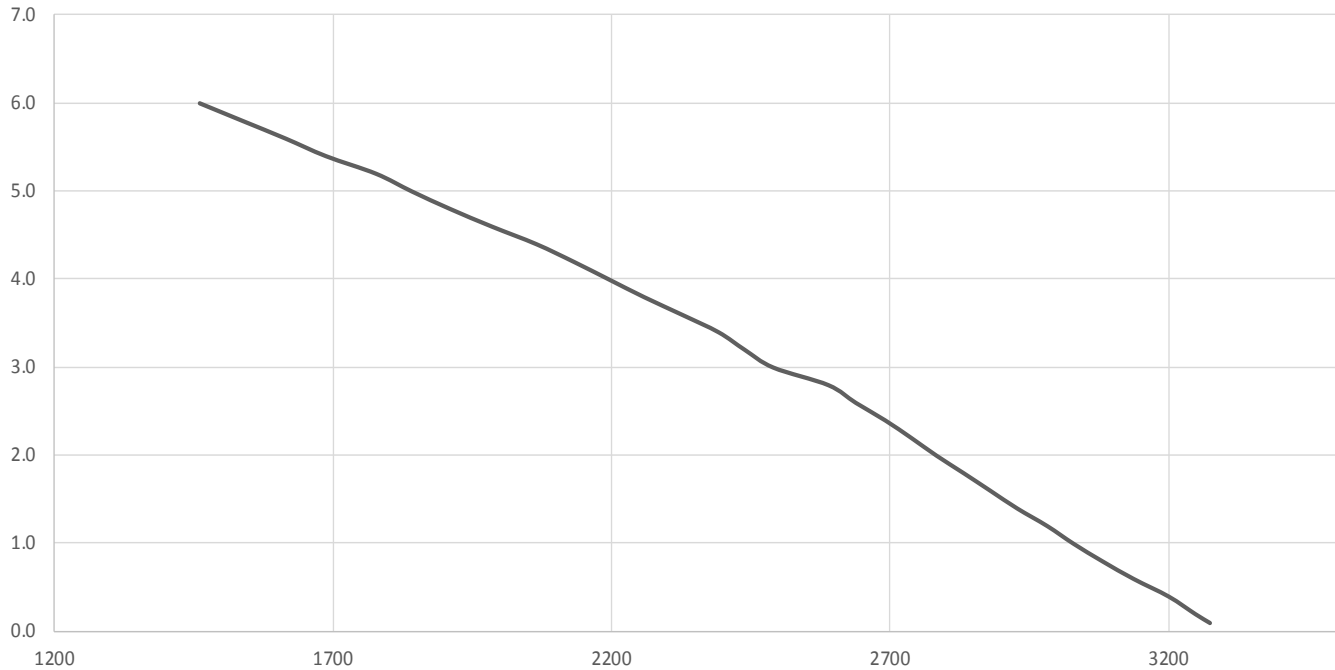

Air flow test with inlet duct, dry coil				
Inlet air temp (°F)	Blower PWM %	External SP (in wc)	Air Flow Rate (SCFM)	Blower Power (W)
70.1	100	0.1	3275	2648
70.0	100	0.2	3249	2663
69.9	100	0.4	3201	2703
69.8	100	0.6	3138	2733
69.8	100	0.8	3082	2766
69.8	100	1.0	3030	2796
70.0	100	1.2	2983	2832
70.0	100	1.4	2929	2859
70.0	100	1.6	2881	2894
70.0	100	1.8	2833	2921
69.9	100	2.0	2784	2950
69.9	100	2.2	2739	2981
70.0	100	2.4	2692	3012
70.0	100	2.6	2639	3043
70.1	100	2.8	2590	3069
70.5	100	3.0	2491	3055
70.4	100	3.2	2440	3081
69.8	100	3.4	2393	3092
69.8	100	3.6	2327	3099
70.5	100	3.8	2259	3113
70.4	100	4.0	2196	3134
70.2	100	4.2	2133	3149
69.9	100	4.4	2066	3167
69.8	100	4.6	1986	3177
69.8	100	4.8	1911	3184
69.8	100	5.0	1842	3189
69.9	100	5.2	1778	3193
70.2	100	5.4	1688	3194
		5.6	1615	
		5.8	1538	
		6.0	1461	

12.5 Ton A10E Blower

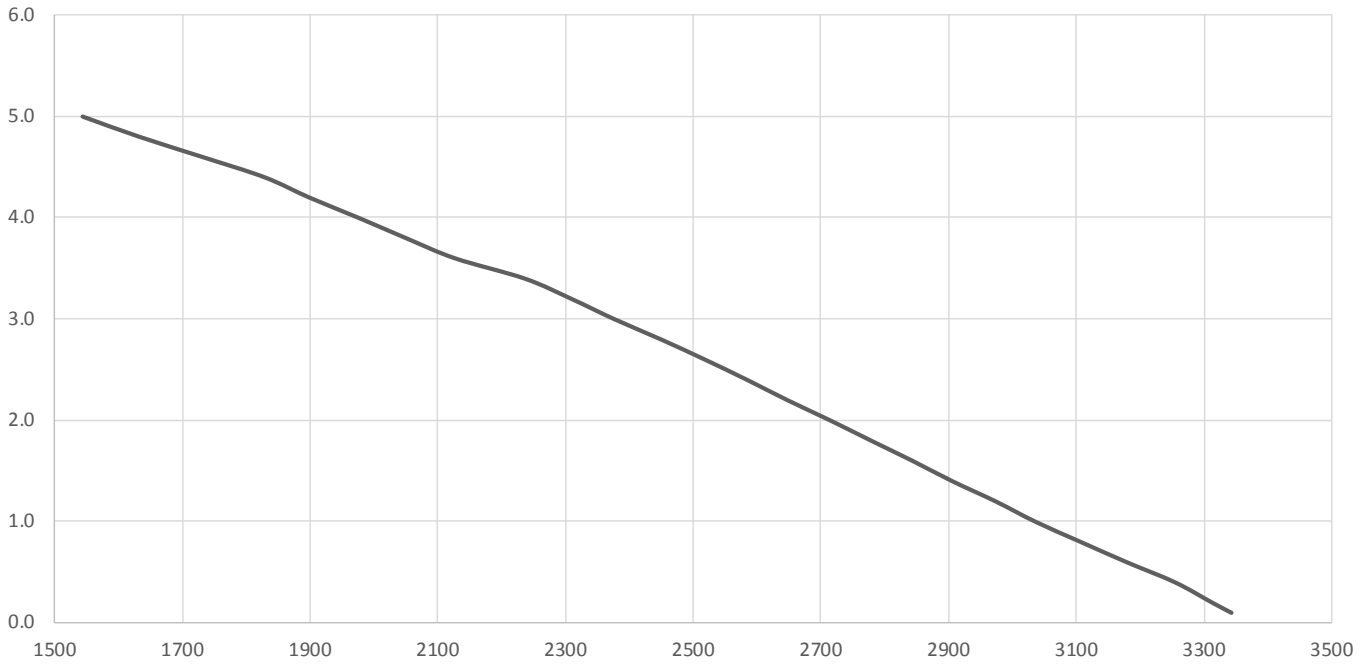

Air flow test with inlet duct, dry coil						
Inlet air temp (°F)	Blower PWM %	External SP (in wc)	Air Flow Rate (SCFM)	Blower Power (W)	Amp Draw	
70.0	100	0.1	3342	2647	6.97	6.91
70.0	100	0.2	3312	2667	7.01	6.96
70.0	100	0.4	3254	2693	7.08	7.04
70.0	100	0.6	3178	2727	7.15	7.10
70.0	100	0.8	3106	2756	7.21	7.18
70.0	100	1.0	3035	2785	7.30	7.26
70.0	100	1.2	2973	2816	7.38	7.34
70.0	100	1.4	2905	2845	7.44	7.41
70.0	100	1.6	2843	2871	7.55	7.49
70.0	100	1.8	2778	2906	7.62	7.56
70.0	100	2.0	2714	2932	7.69	7.63
70.0	100	2.2	2647	2959	7.73	7.69
70.0	100	2.4	2584	2986	7.83	7.76
70.0	100	2.6	2518	3015	7.89	7.85
70.0	100	2.8	2449	3043	7.98	7.94
70.0	100	3.0	2376	3071	8.08	8.00
70.0	100	3.2	2309	3104	8.13	8.06
70.0	100	3.4	2236	3116	8.18	8.12
70.0	100	3.6	2127	3148	8.25	8.17
70.0	100	3.8	2050	3168	8.31	8.27
70.0	100	4.0	1976	3184	8.36	8.29
70.0	100	4.2	1899	3203	8.41	8.37
70.0	100	4.4	1829	3226	8.46	8.39
70.0	100	4.6	1732	3246	8.52	8.44
70.0	100	4.8	1633	3254	8.55	8.48
70.0	100	5.0	1544	3265	8.59	8.53
70.0	100	5.2	1393	3279	8.64	8.60

12.5 Ton A11E Blower

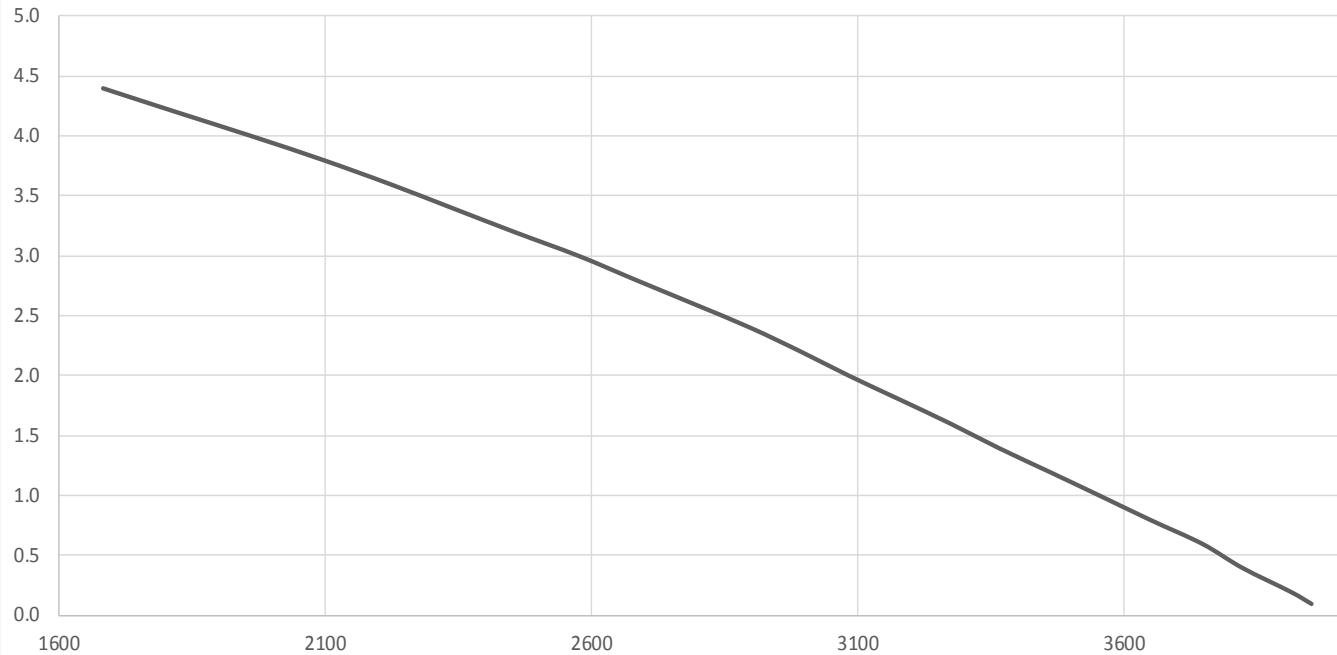

Air flow test with inlet duct, dry coil						
Inlet air temp (°F)	Blower PWM %	External SP (in wc)	Air Flow Rate (SCFM)	Blower Power (W)	Amp Draw	
70.0	100	0.1	3952	2855	7.44	7.45
70.0	100	0.2	3913	2861	7.53	7.51
70.0	100	0.4	3822	2896	7.56	7.54
70.0	100	0.6	3747	2913	7.62	7.59
70.0	100	0.8	3649	2941	7.69	7.66
70.0	100	1.0	3555	2958	7.71	7.68
70.0	100	1.2	3460	2982	7.77	7.76
70.0	100	1.4	3364	2999	7.83	7.81
70.0	100	1.6	3275	3015	7.86	7.83
70.0	100	1.8	3180	3027	7.92	7.88
70.0	100	2.0	3084	3033	7.94	7.91
70.0	100	2.2	2994	3039	7.94	7.95
70.0	100	2.4	2899	3043	7.95	7.95
70.0	100	2.6	2792	3046	7.97	7.96
70.0	100	2.8	2683	3051	7.98	7.97
70.0	100	3.0	2576	3049	7.96	7.94
70.0	100	3.2	2455	3035	7.93	7.89
70.0	100	3.4	2338	3015	7.88	7.86
70.0	100	3.6	2221	2998	7.86	7.80
70.0	100	3.8	2096	2977	7.78	7.75
70.0	100	4.0	1961	2956	7.69	7.67
70.0	100	4.2	1820	2918	7.62	7.60
70.0	100	4.4	1681	2878	7.50	7.49
70.0	100	4.6	1521	2834	7.42	7.40

**Quick Performance Reference Table @ 95°F Ambient Conditions
100% Outside Air Application**

Model Size	Air Entering Evaporator Coil DB/WB	95/73(°F)			95/76(°F)			95/80(°F)		
		Total Capacity (MBH)	Coil Leaving Air Temperature (°F)		Total Capacity (MBH)	Coil Leaving Air Temperature (°F)		Total Capacity (MBH)	Coil Leaving Air Temperature (°F)	
			DB	WB		DB	WB		DB	WB
R7DA-072	800	63	49	48	68	52	51	74	56	56
	1000	69	52	51	74	56	56	81	60	60
	1200	72	55	54	78	59	59	84	63	63
	1400	75	57	56	80	61	61	87	65	65
	1600	76	60	59	81	63	62	88	66	66
	1800	77	62	61	83	66	65	89	67	67
R7DA-090	1000	82	47	47	88	51	51	96	55	
	1200	88	52	51	95	55	55	103	58	58
	1400	92	55	54	99	58	58	108	62	62
	1600	95	57	56	102	61	60	111	64	64
	1800	98	58	58	104	62	62	114	66	65
	2000	99	59	58	104	62	62	114	66	65
	2200	99	60	59	105	63	62	114	66	66
2400	99	61	60	105	64	63	114	67	67	
R7DA-120	1200	103	46	45	110	49	48	120	52	52
	1500	111	50	50	118	53	53	127	57	57
	1800	117	53	53	124	56	56	134	60	60
	2100	121	55	55	128	58	58	139	62	62
	2400	122	57	57	129	60	60	141	64	64
	2700	121	59	58	128	61	61	140	66	65
	3000	118	60	59	125	63	63	137	67	66
	3300	113	61	60	120	64	63	132	67	67
R7DA-150	1700	133	48	48	140	51	51	150	56	55
	2000	139	51	51	146	55	55	156	58	57
	2300	145	54	54	151	58	58	161	62	62
	2600	149	57	56	156	60	60	165	64	64
	2900	153	59	58	159	62	61	169	66	66
	3200	155	61	59	162	64	62	171	68	67
	3500	157	63	61	163	66	64	173	70	68
3800	158	65	62	164	67	65	173	71	69	



We Encourage
Professionalism

Through Technician
Certification by NATE



HRAI
✓ MEMBER COMPANY

USA
DESIGNED &
ASSEMBLED 

**For complete catalog information including submittals,
energy calculations, dimension drawings, and more go to
www.ReznorHVAC.com or call 800-695-1901.**

*Note: In keeping with our policy of continuous
product improvement, we reserve the right to alter,
at any time, the design, construction, dimensions,
weights, etc., of equipment information shown here.*