

# INSTALLATION INSTRUCTIONS

## Universal Compressor Start Kit (No. 912933)

### IMPORTANT SAFETY INFORMATION

These instructions are primarily intended to assist qualified individuals experienced in the proper servicing of heating and air conditioning appliances. Some local codes require licensed installation/service personnel for this type equipment. Use of this kit must be in accordance with these instructions and with all applicable national and local codes and standards.

INSTALLER: Please read all instructions thoroughly before servicing this equipment. Pay attention to all safety warnings and any other special notes highlighted in the manual. Safety markings are used frequently throughout this manual to designate a degree or level of seriousness and should not be ignored. **WARNING** - Indicates a potentially hazardous situation that if not avoided, could result in personal injury or death. **CAUTION** - Indicates a potentially hazardous situation that if not avoided, may result in minor or moderate injury or property damage.

### **WARNING:**

The safety information listed in this manual must be followed during the installation, service, and operation of this unit. Unqualified individuals should not attempt to interpret these instructions or install this equipment. Failure to follow safety recommendations could result in possible damage to the equipment, serious personal injury or death.

### **WARNING:**

#### ELECTRICAL SHOCK, FIRE OR EXPLOSION HAZARD

Failure to follow safety warnings exactly could result in serious injury or property damage.

Improper servicing could result in dangerous operation, serious injury, death or property damage.

- Before servicing, disconnect all electrical power to furnace.
- When servicing controls, label all wires prior to disconnecting. Reconnect wires correctly.
- Verify proper operation after servicing.

### ABOUT THE START KIT

This compressor start kit includes the following items:

Description	Quantity
Compressor Start Assy .....	1
Mounting Brackets .....	2
Plastic Tie-Wrap .....	1
Screws .....	4
Installation Instructions .....	1

Start Kits are designed to provide additional starting torque for air conditioners or heat pumps equipped with compressors using a permanent split capacitor (PSC) single phase motor. This type of motor does not require a start kit under normal operating conditions, but, because low starting torque is inherent with PSC motors, special conditions such as low voltage and exceptionally high operating temperatures, short thermostat cycles, etc., can interfere with compressor starting.

- For Single Package Series Air Conditioners and Heat Pumps use the vertical bracket as shown in Figure 2.
- For Single Package Gas/Electric Models, use the horizontal bracket as shown in Figure 3.
- For Split System Air Conditioners and Heat Pumps no bracket is necessary.

### INSTALLATION SEQUENCE

1. **IMPORTANT!** Turn the power off to the unit.
2. Decide which application is required for the unit. The starting relay is position sensitive and is marked **UP** on the side of the relay. Make sure the relay is mounted so that UP faces upward. See Figures 1-3 for proper relay orientation.
3. Remove the control panel cover.
4. Attach the kit to the designated location in the control panel with the provided screws. For split system units, mount capacitor and relay at the designated locations inside the control panel. **NOTE:** This relay may be equipped with a universal bracket. With a pair of pliers, break off any portion of the bracket that prevents proper installation.
5. Attach the compressor start assembly to the proper bracket using the capacitor strap and provided screws. **NOTE:** For split system units, omit this step.
6. Connect the **BLACK** wire (Figure 1) from **TERMINAL 5** on the start relay to **T2** on the contactor.
7. Connect the **RED** wire from **TERMINAL 2** on the start relay to the compressor capacitor terminal marked **H** (or HERM).
8. Connect the **YELLOW** wire from one terminal of the start capacitor to the compressor capacitor terminal marked **C** (or COMMON). **NOTE:** Terminals 4 & 6 (if available on your relay) are not used for this application.

9. Route the starting kit wires along the side of the existing wiring and tie-wrap all of the wires together with the provided tie-wrap.
10. After installing the compressor start kit, place the enclosed wiring diagram on the control panel cover next to the unit wiring diagram.
11. Replace the control panel cover.
12. Restore power to the unit and check unit operation with the start kit installed.

**NOTE:** Your relay may appear different than the one shown in Figures 1-3. However the wires should still be connected to the same numbered terminals as detailed in steps 6-8.

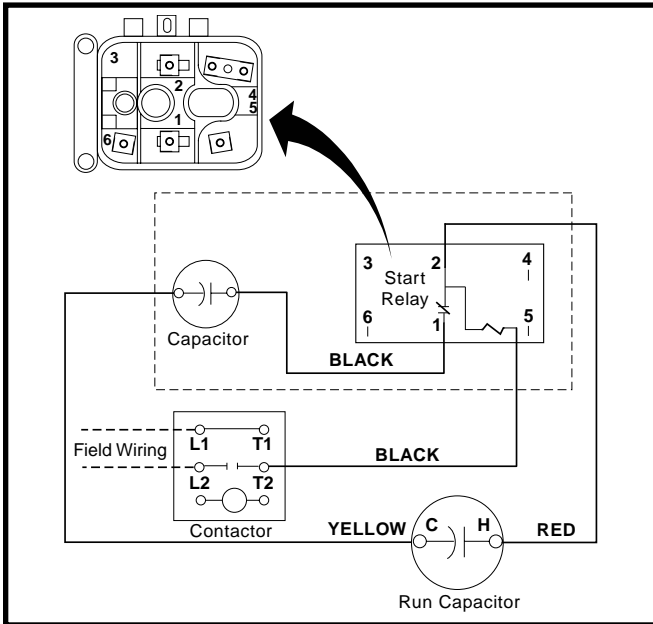

**Figure 1. Wiring Diagram**

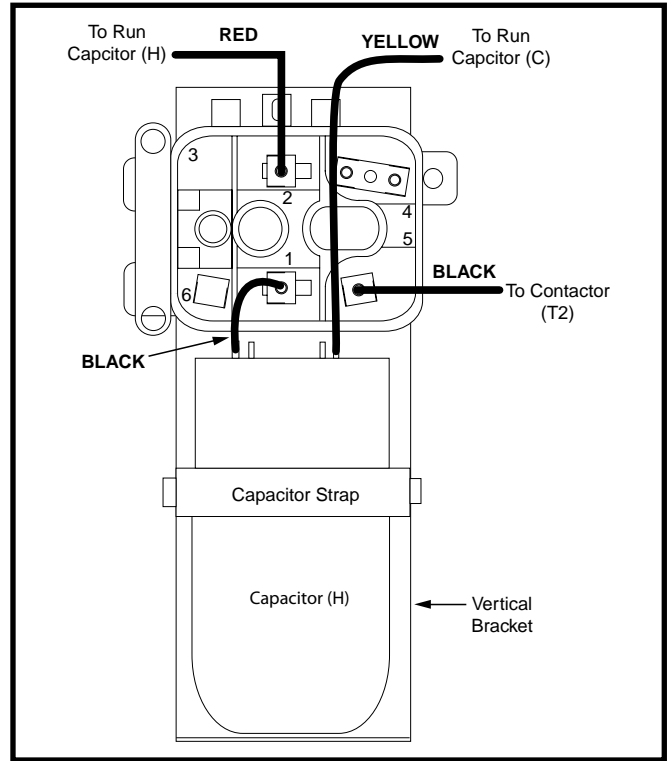

**Figure 2. Vertical Bracket Installation**

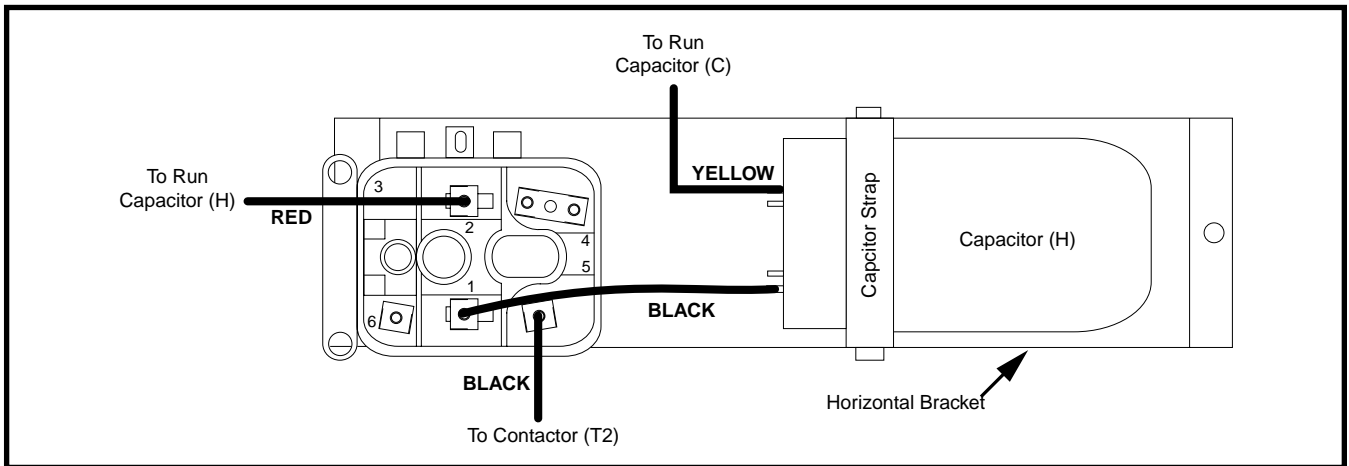

**Figure 3. Horizontal Bracket Installation**

**INSTALLER: Leave these instructions with the equipment owner.**

**NORDYNE**  
COMPLETE COMFORT. GENUINE VALUE.

Specifications & illustrations subject to change without notice or incurring obligations.  
O' Fallon MO (04/13)



**709412A** (Replaces 7094120)