

# WIRING DIAGRAM

## Packaged Two Stage Heat/Two Stage Electric Air Conditioner

208/230 Volt Single Phase

60Hz

### NOTES:

1. Disconnect power before servicing.
2. For supply connections use copper conductors only.
3. Not suitable on systems that exceed 150V to ground.

4. If any of the original wire as supplied with the furnace must be replaced, it must be replaced with wiring material having a temperature rating of at least 105°C.
5. For supply wire ampacities and overcurrent protection, see unit rating plate.

1. Couper le courant avant de faire letretien.
2. Employez uniquement des conducteurs en cuivre.
3. Ne convient pas aux installations de plus de 150 V a la terre.

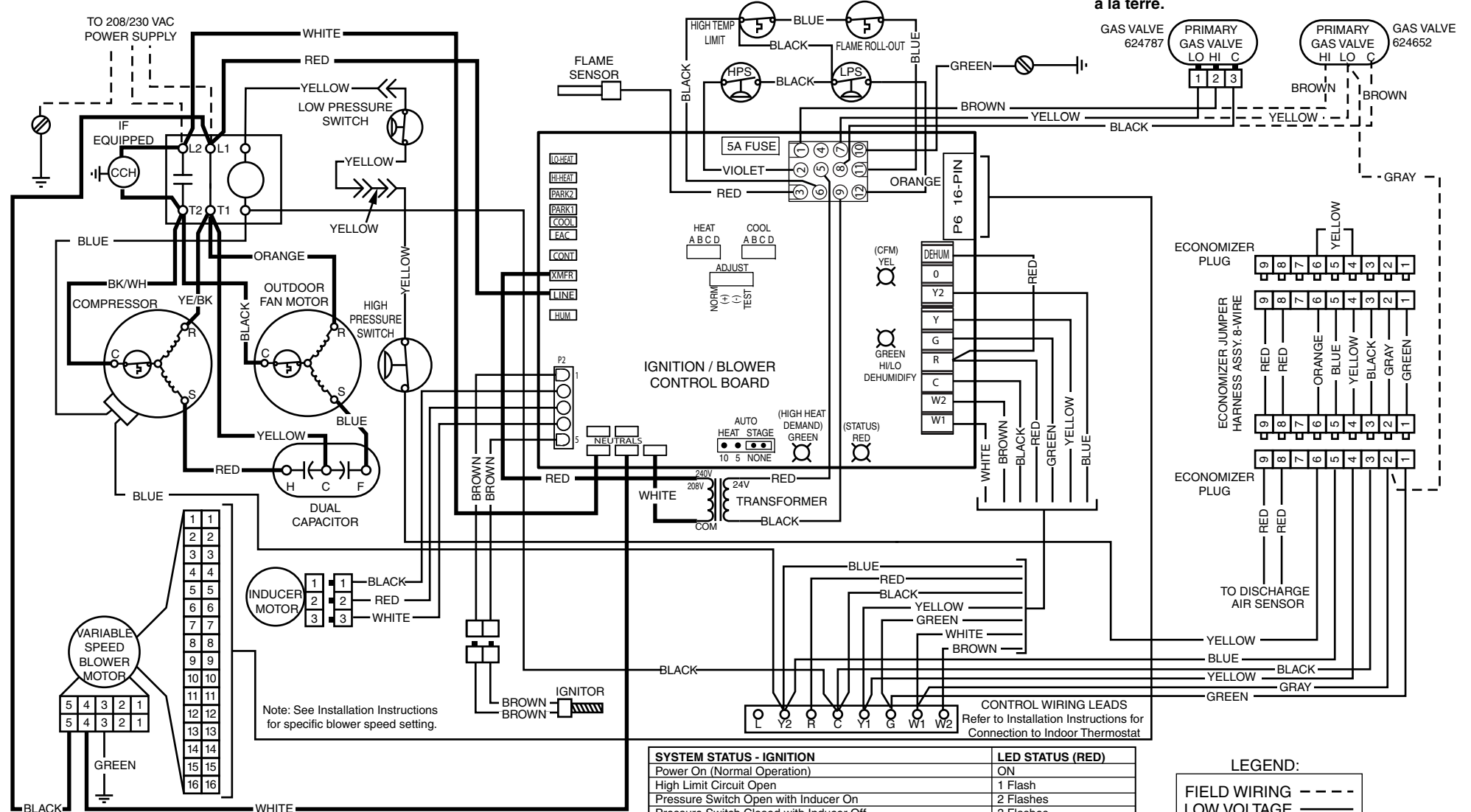

SYSTEM STATUS - 2nd STAGE HEAT DEMAND	LED STATUS (GREEN)
No demand for 2nd stage heat	OFF
2nd stage heat demand (Normal operation)	ON
2nd stage heat demand, high pressure switch not closed	Flashing

SYSTEM STATUS - HI/LO DEHUMIDIFY (Cooling Mode only)	LED STATUS (GREEN)
Factory jumper wire "R" to "DEHUM" in place or "Close on Fall" humidistat (Low humidity) - Closed	ON
Humidistat open (High Humidity) Low Speed Blower call	OFF

SYSTEM STATUS - IGNITION	LED STATUS (RED)
Power On (Normal Operation)	ON
High Limit Circuit Open	1 Flash
Pressure Switch Open with Inducer On	2 Flashes
Pressure Switch Closed with Inducer Off	3 Flashes
Failed Ignition (5 attempts) - Control in 1 Hour Lockout	4 Flashes
208-230 Volt Polarity Issue	5 Flashes
Excess High limit trips (5) within one call for heat	6 Flashes
Excess pressure switch cycles (5) within one call for heat	7 Flashes
Excess flame dropouts (5) within one call for heat	8 Flashes
Not Used	9 Flashes
Flame present with gas valve Off	10 Flashes

SYSTEM STATUS - CFM	LED STATUS (YELLOW)
NOT USED	OFF

**LEGEND:**

FIELD WIRING - - - - -

LOW VOLTAGE ———

HIGH VOLTAGE ———

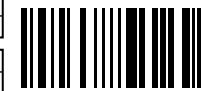

7111820  
(Replaces 7111270)