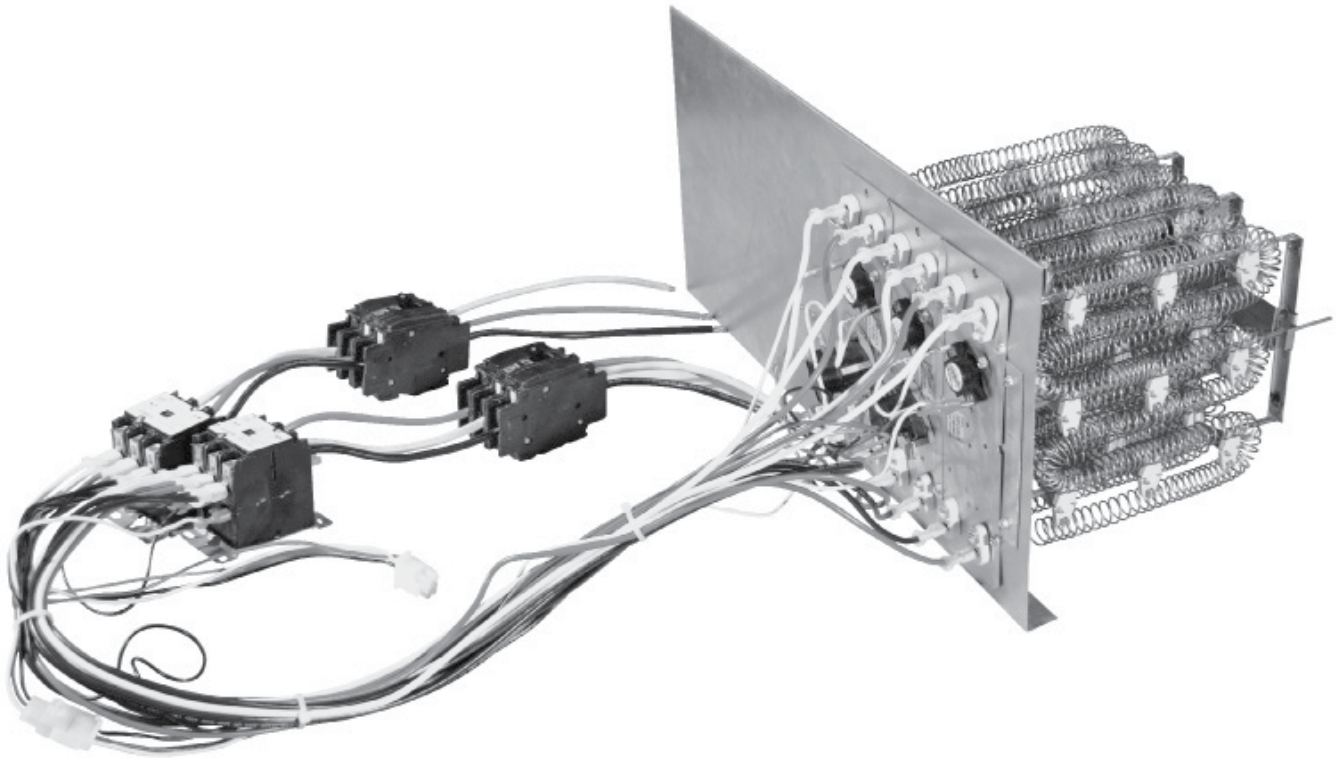


# HEATER KIT INSTALLATION INSTRUCTIONS

**H9HK SERIES HEATER KITS FOR INSTALLATION IN 208/240V, 480V, AND 575V LIGHT COMMERCIAL PACKAGED AIR CONDITIONERS AND PACKAGED HEAT PUMPS**



**NOTE: Model H9HK035Q-21 shown.**

## IMPORTANT

### ATTENTION INSTALLERS:

These instructions are primarily intended to assist qualified individuals experienced in the proper installation of this appliance. Some local codes require licensed installation/service personnel for this type of equipment. All installations must be in accordance with these instructions and with all applicable national and local codes and standards.

Please read all instructions carefully before starting the installation. Return these instructions to the customer's package for future reference.

**DO NOT DESTROY. PLEASE READ CAREFULLY AND KEEP IN A SAFE PLACE FOR FUTURE REFERENCE.**

## TABLE OF CONTENTS

<b>IMPORTANT SAFETY INFORMATION</b> .....	<b>2</b>
<b>GENERAL INFORMATION</b> .....	<b>2</b>
Clearances to Combustibles .....	3
Wiring Diagrams .....	3
Clearances .....	3
<b>ELECTRICAL SUPPLY</b> .....	<b>3</b>
Installation Preparations .....	3
Terminal Blocks .....	3
Circuit Options .....	3
Single Branch Circuit Electrical Connection .....	3
Multiple Branch Circuit Electrical Connection .....	3
Circuit Breakers .....	3
Breaker Removal .....	4
<b>HEAT KIT INSTALLATION</b> .....	<b>4</b>
<b>AIRFLOW</b> .....	<b>6</b>
<b>FIGURES AND TABLES</b> .....	<b>6</b>
Table 3. Heater Kit Model Cross Reference .....	6
Electrical Data .....	7
Table 4. MCA/MOP Data (Single Circuit) .....	7
Table 5. MCA/MOP Data (Multiple Circuit) .....	8
Electrical Diagrams .....	9
Figure 13. Single and Dual Power Supply Connections	9
Figure 14. Wiring Diagram for 9 kW, 240V, 3-Phase .....	10
Figure 15. Wiring Diagram for 9 kW, 480V, 3-Phase .....	11
Figure 16. Wiring Diagram for 10 kW, 575V, 3-Phase .....	12
Figure 17. Wiring Diagram for 18 kW, 240V, 3-Phase .....	13
Figure 18. Wiring Diagram for 18 kW, 480V, 3-Phase .....	14
Figure 19. Wiring Diagram for 20 kW, 575V, 3-Phase .....	15
Figure 20. Wiring Diagram for 30 and 35 kW, 240V, 3-Phase .....	16
Figure 21. Wiring Diagram for 30 and 35 kW, 480V, 3-Phase .....	17
Figure 22. Wiring Diagram for 30 kW, 575V, 3-Phase .....	18
Figure 23. Wiring Diagram for 40 kW, 575V, 3-Phase .....	19

## IMPORTANT SAFETY INFORMATION

INSTALLER: Please read all instructions before servicing this equipment. Pay attention to all safety warnings and any other special notes highlighted in the manual. Safety markings are used frequently throughout this manual to designate a degree or level of seriousness and should not be ignored. **WARNING** indicates a potentially hazardous situation that if not avoided, could result in personal injury or death. **CAUTION** indicates a potentially hazardous situation that if not avoided, may result in minor or moderate injury or property damage.

### **WARNING:**

**RISK OF ELECTRICAL SHOCK**  
**Shut off all electrical power to the unit before performing any maintenance or service on the system. Failure to follow this warning can cause serious injury, fire, electrical shock, or death.**

- The installer performing this work assumes all responsibility when installing this kit. These instructions are primarily intended to assist qualified individuals experienced in the proper installation of these components. Some local codes may require licensed installation/service personnel for this type of equipment. Safety should always be the deciding factor when installing this product and using common sense plays an important role as well. Improper installation of the components or failure to follow safety warnings could result in serious injury, death, or property damage.
- Unless noted otherwise in these instructions, only factory authorized parts or accessory kits may be used with this product. Improper installation, service, adjustment, or maintenance may cause fire, electrical shock or other hazardous conditions which may result in personal injury or property damage.
- Please read all instructions carefully before starting the installation. If a problem occurs, check the instructions and follow recommendations given.
- The information shown in these instructions must be followed during the installation of this kit. Unqualified individuals should not attempt to interpret these instructions or install this equipment. If you do not possess mechanical skills or tools, call your local dealer for assistance.
- Use caution when handling the appliance or removing components. Personal injury can occur from sharp metal edges present in all sheet metal constructed equipment.

## GENERAL INFORMATION

H9HK heater kits are approved for use in P7TQ packaged air conditioners and Q7TQ packaged heat pumps when applied and installed according to these instructions. Use the model identification code in [Figure 1](#), [\(page 2\)](#) and [Table 1](#), [\(page 3\)](#) for approved H9HK Heat kit applications in air conditioner and heat pump systems. Refer to the National Electric Code (ANSI/NFPA 70) or in Canada the Canadian Electric Code Part 1 (CSA C.22.1) and applicable local codes

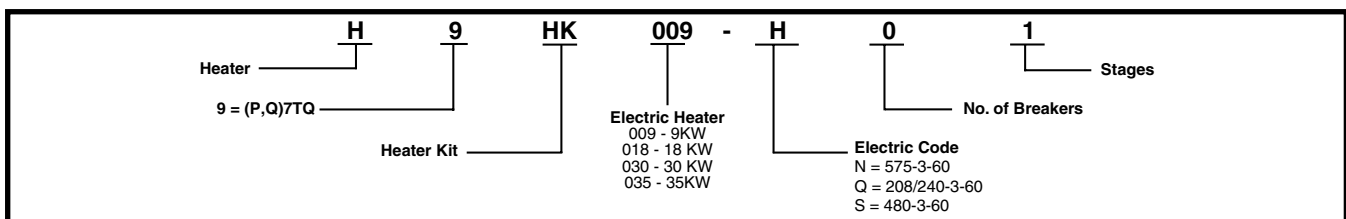


Figure 1. Heater Kit Identification Code

HEATER KITS	DESCRIPTION	PART NUMBER
<b>3 PHASE 208/240V</b>	H9HK009Q-01 (9kw)	1011669
	H9HK018Q-11 (18kw)	1011672
	H9HK030Q-21 (30kw)	1011675
	H9HK035Q-21 (35kw)	1011678
<b>3 PHASE 480V</b>	H9HK009S-01 (9kw)	1011670
	H9HK018S-01 (18kw)	1011673
	H9HK030S-01 (30kw)	1011676
	H9HK035S-01 (35kw)	1011679
<b>3 PHASE 575V</b>	H9HK009N-01 (9kw)	1011671
	H9HK018N-01 (18kw)	1011674
	H9HK030N-01 (30kw)	1011677
	H9HK035N-01 (35kw)	1011680

**Table 1. Heater Kits and Part Numbers**

for overcurrent protection and disconnect requirements. **NOTE:** If any of the original wiring supplied with the unit must be replaced, it must be replaced with material of the same gauge and temperature rating.

### Clearances to Combustibles

All units are approved for zero clearance to combustibles when installed according to these instructions and other instructions included with the unit and other approved accessories.

### Wiring Diagrams

Wiring Diagrams are shipped with each H9HK heater kit assembly. Attach the heater kit wiring diagram label over the bottom half of Sheet #2 of the unit wiring diagram label on the control panel access door. For proper adherence, make sure the surface is clean and free of oil before applying.

### Clearances

All H9HK electric heater kits are approved for use in installations with zero-clearance to combustibles at any blower speed allowed on the units blower performance charts for both Horizontal and Downflow applications when installed according to these instructions and other instructions included with the unit and other approved accessories. See note (in bold type) for vertical duct applications in Heat Kit Installation section on [page 4](#).

## ELECTRICAL SUPPLY

All wiring must comply with the current revision of the National Electric Code and must be sized for the minimum ampacities as listed on the unit data label or in [Table 1](#). Refer to the detailed wiring diagrams for proper connections: [Figure 13 \(page 9\)](#), [Figure 14 \(page 10\)](#), [Figure 15 \(page 11\)](#), [Figure 16 \(page 12\)](#), [Figure 17 \(page 13\)](#), [Figure 18 \(page 14\)](#), [Figure 19 \(page 15\)](#), [Figure 20 \(page 16\)](#), [Figure 21 \(page 17\)](#), [Figure 22 \(page 18\)](#), and [Figure 23 \(page 19\)](#).

If the unit was previously installed without electric heat, the existing supply wiring may not be sufficient to handle the increased load. See the unit rating label or [Table 4 \(page 7\)](#) or [Table 5 \(page 8\)](#) for minimum circuit ampacities and maximum overcurrent protection ratings.

### Installation Preparations

Before proceeding with the electrical connections, make sure that the voltage, frequency, and phase of the supply source are the same as those specified on the unit rating label. Also verify that the service provided by the utility is sufficient to handle the additional load imposed by this equipment.

### Terminal Blocks

Approved H9HK heater kits are shipped ready to install using single or dual circuit electrical supply and existing factory installed terminal blocks. If dual circuit supply is desired, follow instructions included under Multiple Branch Circuit Electrical Connections section.

**NOTE:** Use of the 3 pole terminal block found in the main control panel is for the unit's refrigerant cooling and heat pump circuit only. This circuit includes:

- Compressors
- Blower motors
- OD fan motors
- Low Voltage transformer (all unit electrical loads)

### Circuit Options

P7TQ and Q7TQ units installed with electric heat may be wired for single or multiple circuit supply connections.

#### Single Branch Circuit Electrical Connection

Units are factory ready for addition of H9HK heater kits. See unit rating label or [Table 4 \(page 7\)](#) for single point power circuit Minimum Circuit Ampacity (MCA) and Maximum Over-Current Protection of branch circuit wiring.

Field wiring will be routed from the branch circuit disconnect to this 3 pole terminal block for both heating and cooling operation.

#### Multiple Branch Circuit Electrical Connection

For Dual Point Power Circuit connections see the unit rating plate or electrical data in [Table 5 \(page 8\)](#) for proper high voltage branch circuit requirements. Both 3 pole terminal blocks provided in the unit will be used for converting to dual supply connections.

The 3 pole terminal block located in the electric heat vestibule is for connection of the electric heater kit branch circuit wiring. Field wiring will be routed from the electric heat branch circuit disconnect to this 3 pole terminal block for heating operation.

The factory supplied red, yellow, and black wires connected to the electric heat terminal block from the main unit 3 pole terminal block must be removed. These 3 wires (if long enough) may be used for connection between the unit main control panel 3 pole terminal block and the second branch circuit power supply disconnect for cooling and blower operation. See [Figure 13 \(page 9\)](#).

### Circuit Breakers

If circuit breakers are used for any circuit, they must be used for all electric heat circuits. Use one breaker for each circuit. See [Table 3, \(page 6\)](#). If circuit breakers are not being used, proceed to the Heat Kit Installation section on [page 4](#).

#### IMPORTANT NOTE:

**Circuit breakers (if installed) in the unit with the addition of heater kits are for short circuit protection of the internal heater element circuit wiring and DO NOT serve as a unit disconnect. The circuit breakers DO NOT provide over-current protection of the supply wiring.**

- Whether or not circuit breakers are used in the units, overcurrent protection of the unit supply wire must be provided at the branch circuit distribution panel and must be sized as shown in [Table 3, \(page 6\)](#) or on the unit rating label and according to the National Electric Code, Canadian Electrical Code and applicable local codes. **NOTE:** In most cases the overcurrent protection specified on the unit rating label is less than the 60 amp rating of the circuit breakers used in the units. This is because the function of the overcurrent protection required at the distribution panel (field supplied) and the unit mounted breakers is different.

### Breaker Removal

Insert a screwdriver into the hole (in the white release tab) and pull down. **NOTE:** The white release tab is located at the base of the breaker under the line side (right) terminals.

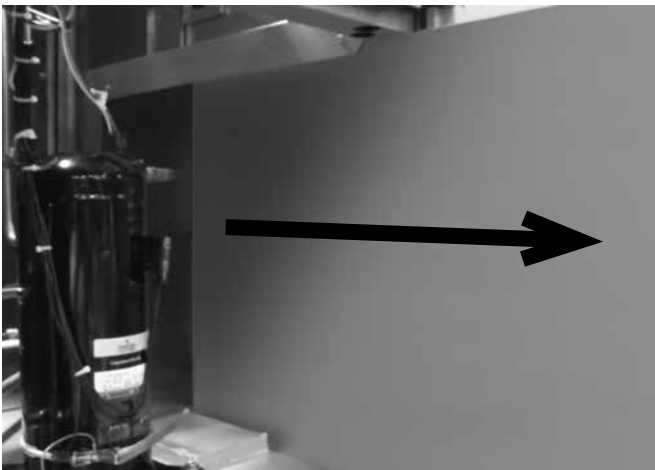
## HEAT KIT INSTALLATION

Rooftop installations with vertical ducts must be provided with a 90-degree elbow installed in the supply duct to comply with U. L. (Underwriters Laboratories) codes for use with electric heat so the elements are not directly over a supply grille.



**Figure 2. Compressor Access Panel**

1. Remove Compressor Access panel. See [Figure 2](#).
2. Remove electric heat vestibule cover by pulling straight out, perpendicular to the unit. See [Figure 3](#).

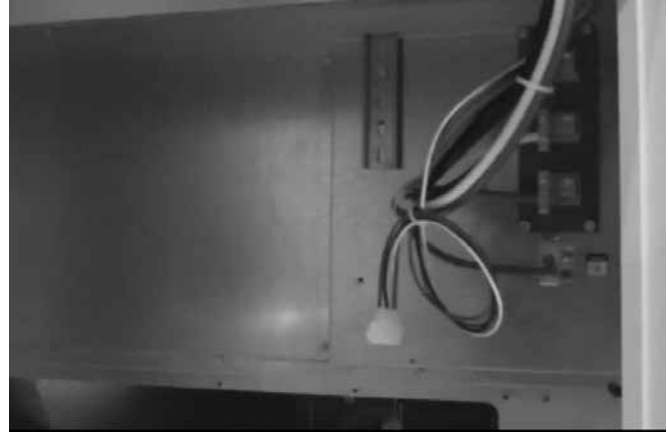


**Figure 3. Electric Heat Kit Access Panel**

3. Remove electric heat access plate. Retain all screws and foam wire guards for later use. See [Figure 4](#).
4. Install the DIN rail mounting bracket inside of the unit and tightly secure it with two screws. See [Figure 5](#). **NOTE:** This step needs to be performed only if circuit breakers are included with your kit.

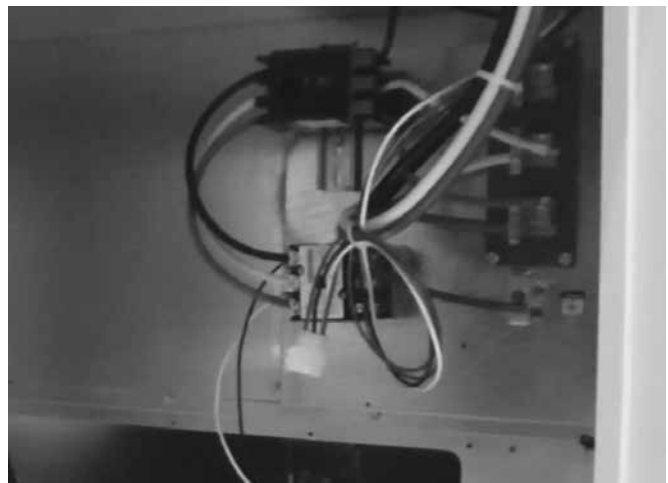


**Figure 4. Electric Heat Access Plate**



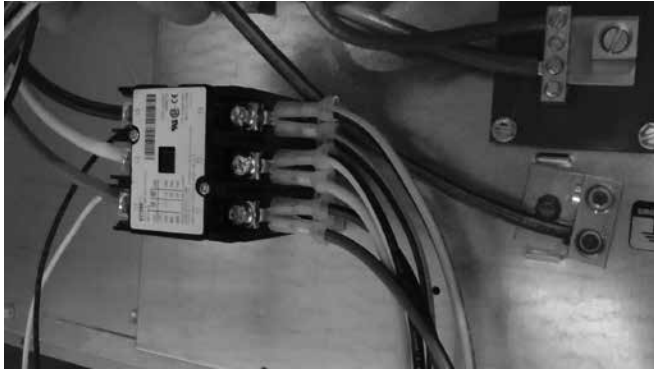
**Figure 5. DIN Rail Location**

5. Mount circuit breakers (if included with your kit) onto the DIN rail. **NOTE:** Secure circuit breaker(s) to bracket by hooking the rear top groove over the din rail and pushing in on the bottom until it snaps into place. Refer to [Table 3, \(page 6\)](#) for quantity.
6. Attach Black (T1), Yellow (T2), and Red (T3) power leads from the circuit breaker(s) to L1, L2, and L3 on the 3 pole terminal block.
7. Mount element control contactor (1 or 2 depending on kit) to the control panel with two screws. Make sure L1/ L2/L3 wiring point to the left. See [Figure 6](#).



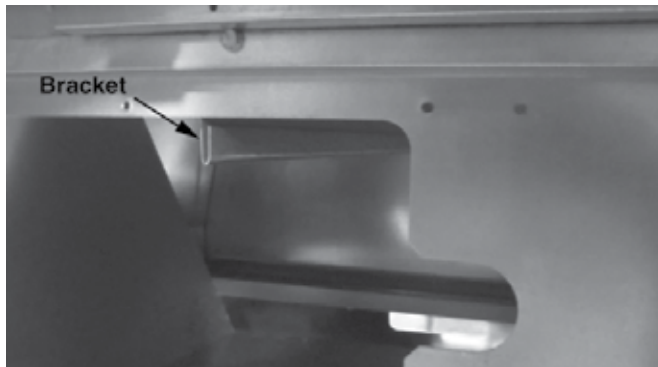
**Figure 6. Single Circuit Breaker and Contactor**

- Attach Black (T1), Yellow (T2), and Red (T3) of contactor to circuit breaker L1, L2, and L3 as shown in [Figure 7](#) or attach directly to 3 pole terminal block L1, L2, and L3 if no breaker is used.

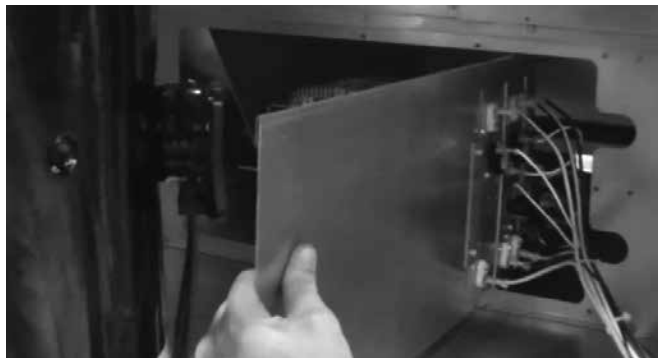


**Figure 7. Element Line Voltage Connections**

- Carefully slide electric heat kit into place by aligning the formed “J” hooks at the top of the element mounting plate to the element mounting bracket located under the blower mounting deck. See [Figure 8](#) and [Figure 9](#).



**Figure 8. Bracket Location**

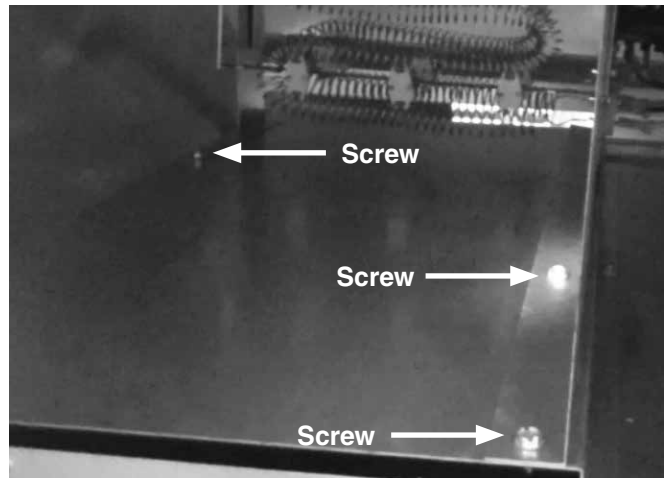


**Figure 9. Installation of Heater Elements**

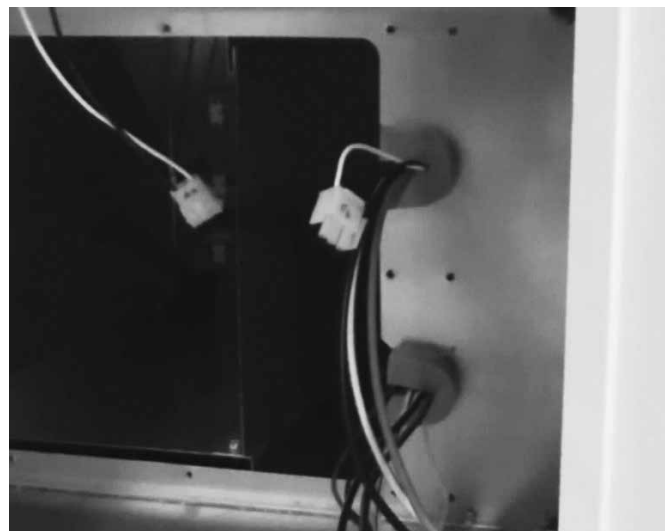
- Secure the element assembly by aligning the two clearance holes in the bottom flange of the element mounting plate to the bottom pan and then one in the rear of the element assembly support bracket (excluding 575V kits) as shown in [Figure 10](#) and [Figure 11](#).
- Route all wiring out the two wire passage holes and foam wire guards. See [Figure 12](#). **NOTE:** Power wires can exit through either opening but control wiring should exit the top.
- Attach the high voltage Black (L1), Yellow (L2), and Red (L3) element wires to T1, T2, and T3 on the 3 pole control contactor.



**Figure 10. Element Support Bracket**



**Figure 11. Securement Screw Locations (x3)**



**Figure 12. Wire Passage Foam Grommets**

- Connect and securely lock the low voltage 3 pin plug from the electric element assembly to the mating plug from the 3 pole contactor.
- Connect and securely lock the low voltage 6 pin plug from the electric element assembly to the mating plug from the main unit control panel.

15. Replace the electric heat access plate using screws removed in Step 3. **NOTE:** Make sure the wires are not pinched and foam guards are in place.
16. Replace the electric heat vestibule cover removed in Step 2 and secure with screw.
17. Replace the compressor access panel.

### AIRFLOW

The maximum external static pressure (ESP) for the unit is listed on the unit rating label.

The blower speed is preset at the factory for optimum operation in Heating and Cooling modes. It may be necessary for some applications to change the factory set speed due to the addition of electric heat kits. To change the blower speed see the “Blower Speed” section in the Installation Instructions shipped with the unit. If a lower blower speed is desired, then the heater element high temperature limits must be checked for proper operation. Nuisance tripping and cycling of the limits may result with too little of airflow. Limit operation should be checked with return air temperatures between 72°F and 78°F. If a higher blower speed is desired from the factory then no other testing is required.

### IMPORTANT NOTE:

**When installing H9HK heater kits In P7TQ/Q7TQ Series packaged units (on duct systems where the unit ESP is greater than that marked on the unit rating label) the heater kit may require the addition of a high static drive kit to increase blower performance. For blower data See the unit blower performance tables in the Installation Instructions shipped with the unit. For accessory description and part number info refer to the Technical Sales literature.**

Nominal heater kit temperature rise data shown in [Table 2](#) was calculated using the formula below.

$$\text{Temp Rise: } \Delta T = (\text{Btu/h}) / (\text{CFM} * 1.08)$$

**NOTE:** Generally the heat rise should be near values shown. Anything greater than 3–5° above that shown should be avoided.

MODEL NUMBER	NOMINAL RATED CFM	TEMPERATURE RISE °F (°C)*			
		9 KW	18 KW	30 KW	35 KW
P7TQ072-*	2,550	11°F (6°C)	22°F (12°C)	37°F (21°C)	43°F (24°C)
P7TQ090-*	3,150	9°F (5°C)	18°F (10°C)	30°F (17°C)	35°F (19°C)
P7TQ120-*	3,450	8°F (4°C)	16°F (9°C)	27°F (15°C)	32°F (18°C)
P7TQ150-*	4,300	7°F (4°C)	13°F (7°C)	22°F (12°C)	26°F (14°C)

\*Temperature rise calculation = rise (°F) = (kW\*3413) / 1.08 / nominal CFM.

**NOTE:** For 208–230V electric heat kits operating @ 208 Volts, the kW rating is derated 25%, therefore temperature rise will be lower than the values in the table.

**Table 2. Heat Rise and Range**

### FIGURES AND TABLES

NOMINAL TONNAGE	UNIT	NOMINAL KW	HEATER KIT MODEL	HEATER KIT PART NUMBER	BREAKERS	WIRING DIAGRAM NUMBER	LIMIT
6-, 7.5-, 10-, and 12.5-ton 208–230V, 3PH	P7TQ(072/090/120-C) Q7TQ(072/090/120-C)	9	H9HK009Q-01	1011669	NONE	Figure 14	155°F
		18	H9HK018Q-11	1011672	1	Figure 17	155°F
		30	H9HK030Q-21	1011675	2	Figure 20	210°F
		35	H9HK035Q-21	1011678	2	Figure 20	210°F
6-, 7.5-, 10-, and 12.5-ton 460V, 3PH	P7TQ(072/090/120-D) Q7TQ(072/090/120-D)	9	H9HK009S-01	1011670	NONE	Figure 15	155°F
		18	H9HK018S-01	1011673	NONE	Figure 18	155°F
		30	H9HK030S-01	1011676	NONE	Figure 21	210°F
		35	H9HK035S-01	1011679	NONE	Figure 21	210°F
6-, 7.5-, and 10-ton 575V, 3PH	P7TQ(072/090/120-N) Q7TQ(072/090/120-N)	9	H9HK009N-01	1011671	NONE	Figure 16	170°F
		18	H9HK018N-01	1011674	NONE	Figure 19	170°F
		30	H9HK030N-01	1011677	NONE	Figure 22	155°F
		35	H9HK035N-01	1011680	NONE	Figure 23	155°F

**Table 3. Heater Kit Model Cross Reference**

# Electrical Data

SINGLE CIRCUIT WITH NO ELECTRIC HEAT													
UNIT EQUIPPED WITH:		STANDARD 2-HP 2-SPEED MOTOR			STANDARD 2-HP 2-SPEED MOTOR + POWER EXHAUST			HIGH STATIC DRIVE 3-HP ECM 5-SPEED MOTOR			HIGH STATIC DRIVE 3-HP ECM 5-SPEED MOTOR + POWER EXHAUST		
COOLING TONNAGE*,**	UNIT VOLTAGE***	TOTAL LINE CURRENT	MCA	MOP	TOTAL LINE CURRENT	MCA	MOP	TOTAL LINE CURRENT	MCA	MOP	TOTAL LINE CURRENT	MCA	MOP
6	208-230	26.4	30.8	45	30.4	34.8	50	29.3	33.7	50	33.3	37.7	50
	460	12.8	14.9	20	14.8	16.9	25	14.3	16.4	20	16.3	18.4	25
	575	9.8	11.4	15	11.7	13.3	15	—					
7.5	208-230	36.8	40.1	50	40.8	44.1	50	39.7	43.0	50	43.7	47.0	60
	460	17.7	19.2	25	19.7	21.2	25	19.2	20.7	25	21.2	22.7	25
	575	13.2	14.3	15	15.1	16.2	20	N/A	N/A	N/A	N/A	N/A	N/A
10	208-230	42.6	46.6	60	46.6	50.6	60	45.5	49.5	60	49.5	53.5	60
	460	21.1	23.1	30	23.1	25.1	30	22.6	24.6	30	24.6	26.6	30
	575	15.8	17.2	20	17.7	19.1	20	N/A	N/A	N/A	N/A	N/A	N/A
UNIT EQUIPPED WITH:		STANDARD 3-HP 2-SPEED MOTOR			STANDARD 3-HP 2-SPEED MOTOR + POWER EXHAUST			HIGH STATIC DRIVE 5-HP 2-SPEED MOTOR			HIGH STATIC DRIVE 5-HP 2-SPEED MOTOR + POWER EXHAUST		
COOLING TONNAGE*,**	UNIT VOLTAGE***	TOTAL LINE CURRENT	MCA	MOP	TOTAL LINE CURRENT	MCA	MOP	TOTAL LINE CURRENT	MCA	MOP	TOTAL LINE CURRENT	MCA	MOP
12.5	208-230	53.4	58.2	70	57.4	62.2	80	57.6	62.4	80	61.6	66.4	80
	460	27.3	29.7	35	29.3	31.7	40	29.5	31.9	40	31.5	33.9	40

SINGLE CIRCUIT WITH ELECTRIC HEAT: STANDARD DRIVE MOTOR AND/OR POWER EXHAUST																	
UNIT EQUIPPED WITH:		2-HP 2-SPEED MOTOR + HEATER KIT								2-HP 2-SPEED MOTOR + HEATER KIT + POWER EXHAUST							
COOLING TONNAGE*,**	UNIT VOLTAGE***	MCA				MOP				MCA				MOP			
		9 KW	18 KW	30 KW	35 KW	9 KW	18 KW	30 KW	35 KW	9 KW	18 KW	30 KW	35 KW	9 KW	18 KW	30 KW	35 KW
6	208-240	31.0-34.6	52.9-59.9	82.5-94.1	98.3-112.1	45-45	60-60	90-100	100-125	36.0-39.6	57.9-64.9	87.5-99.1	103.3-117.1	50-50	60-70	90-100	110-125
	480	18.5	30.8	46.9	56.0	20	35	50	60	21.0	33.3	49.4	58.5	25	35	50	60
	575	15.5	28.1	40.6	53.3	20	30	45	60	17.9	30.5	43	55.6	20	35	45	60
7.5	208-240	40.1-40.1	52.9-59.9	82.5-94.1	98.3-112.1	50-50	60-60	90-100	100-125	44.1-44.1	57.9-64.9	87.5-99.1	103.3-117.1	50-50	60-70	90-100	110-125
	480	19.2	30.8	46.9	56.0	25	35	50	60	21.2	33.3	49.4	58.5	25	35	50	60
	575	15.5	28.1	40.6	53.3	20	30	45	60	17.9	30.5	43	55.6	20	35	45	60
10	208-240	46.6-46.6	52.9-59.9	82.5-94.1	98.3-112.1	60-60	60-60	90-100	100-125	50.6-50.6	57.9-64.9	87.5-99.1	103.3-117.1	60-60	60-70	90-100	110-125
	480	23.1	30.8	46.9	56.0	30	35	50	60	25.1	33.3	49.4	58.5	30	35	50	60
	575	17.2	28.1	40.6	53.3	20	30	45	60	19.1	30.5	43	55.6	20	35	45	60
UNIT EQUIPPED WITH:		3-HP 2-SPEED MOTOR + HEATER KIT								3-HP 2-SPEED MOTOR + HEATER KIT + POWER EXHAUST							
COOLING TONNAGE*,**	UNIT VOLTAGE***	MCA				MOP				MCA				MOP			
		9 KW	18 KW	30 KW	35 KW	9 KW	18 KW	30 KW	35 KW	9 KW	18 KW	30 KW	35 KW	9 KW	18 KW	30 KW	35 KW
12.5	208-240	58.2-58.2	58.9-65.9	88.5-100.1	104.3-118.1	70-70	60-70	90-110	110-125	62.2-62.2	63.9-70.9	93.5-105.1	109.3-123.1	80-80	70-80	100-110	110-125
	480	29.7	33.8	49.9	59.0	35	35	50	60	31.7	36.3	52.4	61.9	40	40	60	70

SINGLE CIRCUIT WITH ELECTRIC HEAT: HIGH STATIC DRIVE MOTOR AND/OR POWER EXHAUST																	
UNIT EQUIPPED WITH:		3-HP ECM MOTOR + HEATER KIT								3-HP ECM MOTOR + HEATER KIT + POWER EXHAUST							
COOLING TONNAGE*,**	UNIT VOLTAGE***	MCA				MOP				MCA				MOP			
		9 KW	18 KW	30 KW	35 KW	9 KW	18 KW	30 KW	35 KW	9 KW	18 KW	30 KW	35 KW	9 KW	18 KW	30 KW	35 KW
6	208-240	34.6-38.3	56.5-63.5	86.1-97.8	101.9-115.8	50-50	60-70	90-100	110-125	39.6-43.3	61.5-68.5	91.1-102.8	106.9-120.8	50-50	70-70	100-110	110-125
	480	20.4	32.6	48.8	57.9	25	35	50	60	22.9	35.1	51.3	60.4	25	40	60	70
	575	—															
7.5	208-240	43.0-43.0	56.5-63.5	86.1-97.8	101.9-115.8	50-50	60-70	90-100	110-125	47.0-47.0	61.5-68.5	91.1-102.8	106.9-120.8	60-60	70-70	100-110	110-125
	480	20.7	32.6	48.8	57.9	25	35	50	60	22.9	35.1	51.3	60.4	25	40	60	70
	575	—															
10	208-240	49.5-49.5	56.5-63.5	86.1-97.8	101.9-115.8	60-60	60-70	90-100	110-125	53.5-53.5	61.5-68.5	91.1-102.8	106.9-120.8	60-60	70-70	100-110	110-125
	480	24.6	32.6	48.8	57.9	30	35	50	60	26.6	35.1	51.3	60.4	30	40	60	70
	575	—															
UNIT EQUIPPED WITH:		5-HP 2-SPEED MOTOR + HEATER KIT								5-HP 2-SPEED MOTOR + HEATER KIT + POWER EXHAUST							
COOLING TONNAGE*,**	UNIT VOLTAGE***	MCA				MOP				MCA				MOP			
		9 KW	18 KW	30 KW	35 KW	9 KW	18 KW	30 KW	35 KW	9 KW	18 KW	30 KW	35 KW	9 KW	18 KW	30 KW	35 KW
12.5	208-240	62.4-62.4	64.1-71.1	93.8-105.4	109.5-123.4	80-80	70-80	100-110	110-125	66.4-66.4	69.1-76.1	98.8-110.4	114.5-128.4	80-80	70-80	100-125	125-150
	480	31.9	36.5	52.6	61.8	40	40	60	70	33.9	39.0	55.1	64.3	40	40	60	70

\*For C series units: Nominal unit input voltage = 208-230V/60-Hz/3PH, minimum allowed unit voltage = 187V, and maximum allowed voltage = 253V.

\*\*For D series units: nominal unit input voltage = 460V/60-Hz/3PH, minimum allowed unit voltage = 414V, and maximum allowed voltage = 506V.

\*\*\*To achieve the rated unit performance, unit voltage should be within 2% of nominal.

KEY: FLA = Full Load Amps, MCA = Minimum Circuit Ampacity, RLA = Rated Load Amps, MOP = Maximum Over-Current Protection, and LRA = Locked Rotor Amps.

**Table 4. MCA/MOP Data (Single Circuit)**

MULTIPLE CIRCUIT ELECTRICAL DATA																	
STANDARD 2-HP 2-SPEED MOTOR																	
COOLING TONNAGE***	UNIT VOLTAGE***	COOLING CIRCUIT								HEATING CIRCUIT							
		9 KW		18 KW		30 KW		35 KW		9 KW		18 KW		30 KW		35 KW	
		MCS	MOP	MCS	MOP	MCS	MOP	MCS	MOP	MCS	MOP	MCS	MOP	MCS	MOP	MCS	MOP
6	208-240V	30.8	45.0	30.8	45.0	30.8	45.0	30.8	45.0	23.5-27.1	30-30	45.4-52.3	50-60	75.0-86.6	80-90	90.7-104.6	100-110
	480V	14.9	20.0	14.9	20.0	14.9	20.0	14.9	20.0	14.9	15.0	27.1	30.0	43.3	45.0	52.3	60.0
	575V	11.4	15.0	11.4	15.0	11.4	15.0	11.4	15.0	12.5	15.0	26.0	30.0	37.7	40.0	50.2	60.0
7.5	208-240V	40.1	50	40.1	50	40.1	50	40.1	50	23.5-27.1	30-30	45.4-52.3	50-60	75.0-86.6	80-90	90.7-104.6	100-110
	480V	19.2	25	19.2	25	19.2	25	19.2	25	14.9	15	27.1	30	43.3	45	52.3	60
	575V	14.3	15	14.3	15	14.3	15	14.3	15	12.5	15	26	30	37.7	40	50.2	60
10	208-240V	46.6	60	46.6	60	46.6	60	46.6	60	23.5-27.1	30-30	45.4-52.3	50-60	75.0-86.6	80-90	90.7-104.6	100-110
	480V	23.1	30	23.1	30	23.1	30	23.1	30	14.9	15	27.1	30	43.3	45	52.3	60
	575V	17.2	20	17.2	20	17.2	20	17.2	20	12.5	15	26	30	37.7	40	50.2	60
STANDARD 3-HP 2-SPEED MOTOR																	
12.5	208-240V	58.2	70	58.2	70	58.2	70	58.2	70	23.5-27.1	30-30	45.4-52.3	50-60	75.0-86.6	80-90	90.7-104.6	100-110
	480V	29.7	35	29.7	35	29.7	35	29.7	35	14.9	15	27.1	30	43.3	45	52.3	60
STANDARD 2-HP 2-SPEED MOTOR WITH POWER EXHAUST (OPTIONAL)																	
COOLING TONNAGE***	UNIT VOLTAGE***	COOLING CIRCUIT								HEATING CIRCUIT							
		9 KW		18 KW		30 KW		35 KW		9 KW		18 KW		30 KW		35 KW	
		MCS	MOP	MCS	MOP	MCS	MOP	MCS	MOP	MCS	MOP	MCS	MOP	MCS	MOP	MCS	MOP
6	208-240	34.8	50	34.8	50	34.8	50	34.8	50	23.5-27.1	30-30	45.4-52.3	50-60	75.0-86.6	80-90	90.7-104.6	100-110
	480	16.9	25	16.9	25	16.9	25	16.9	25	14.9	15.0	27.1	30.0	43.3	45.0	52.3	60.0
	575	13.3	15	13.3	15	13.3	15	13.3	15	12.5	15.0	26.0	30.0	37.7	40.0	50.2	60.0
7.5	208-240	44.1	50	44.1	50	44.1	50	44.1	50	23.5-27.1	30-30	45.4-52.3	50-60	75.0-86.6	80-90	90.7-104.6	100-110
	480	21.2	25	21.2	25	21.2	25	21.2	25	14.9	15	27.1	30	43.3	45	52.3	60
	575	16.2	20	16.2	20	16.2	20	16.2	20	12.5	15	26	30	37.7	40	50.2	60
10	208-240	50.6	60	50.6	60	50.6	60	50.6	60	23.5-27.1	30-30	45.4-52.3	50-60	75.0-86.6	80-90	90.7-104.6	100-110
	480	25.1	30	25.1	30	25.1	30	25.1	30	14.9	15	27.1	30	43.3	45	52.3	60
	575	19.1	20	19.1	20	19.1	20	19.1	20	12.5	15	26	30	37.7	40	50.2	60
STANDARD 3-HP 2-SPEED MOTOR WITH POWER EXHAUST (OPTIONAL)																	
12.5	208-240	62.2	80	62.2	80	62.2	80	62.2	80	23.5-27.1	30-30	45.4-52.3	50-60	75.0-86.6	80-90	90.7-104.6	100-110
	480	31.7	40	31.7	40	31.7	40	31.7	40	14.9	15	27.1	30	43.3	45	52.3	60
HIGH STATIC DRIVE (OPTIONAL): 3-HP ECM MOTOR																	
6	208-240	33.7	50	33.7	50	33.7	50	33.7	50	23.5-27.1	30-30	45.4-52.3	50-60	75.0-86.6	80-90	90.7-104.6	100-110
	480	16.4	20	16.4	20	16.4	20	16.4	20	14.9	15.0	27.1	30.0	43.3	45.0	52.3	60.0
	575	—								12.5	15.0	26.0	30.0	37.7	40.0	50.2	60.0
7.5	208-240	43.0	50	43.0	50	43.0	50	43.0	50	23.5-27.1	30-30	45.4-52.3	50-60	75.0-86.6	80-90	90.7-104.6	100-110
	480	20.7	25	20.7	25	20.7	25	20.7	25	14.9	15	27.1	30	43.3	45	52.3	60
	575	—								12.5	15	26	30	37.7	40	50.2	60
10	208-240	49.5	60	49.5	60	49.5	60	49.5	60	23.5-27.1	30-30	45.4-52.3	50-60	75.0-86.6	80-90	90.7-104.6	100-110
	480	24.6	30	24.6	30	24.6	30	24.6	30	14.9	15	27.1	30	43.3	45	52.3	60
	575	—								12.5	15	26	30	37.7	40	50.2	60
HIGH STATIC DRIVE (OPTIONAL): 5-HP 2-SPEED MOTOR																	
12.5	208-240	62.4	80	62.4	80	62.4	80	62.4	80	23.5-27.1	30-30	45.4-52.3	50-60	75.0-86.6	80-90	90.7-104.6	100-110
	480	31.9	40	31.9	40	31.9	40	31.9	40	14.9	15	27.1	30	43.3	45	52.3	60
HIGH STATIC DRIVE (OPTIONAL): 3-HP ECM MOTOR WITH POWER EXHAUST (OPTIONAL)																	
6	208-240	37.7	50	37.7	50	37.7	50	37.7	50	23.5-27.1	30-30	45.4-52.3	50-60	75.0-86.6	80-90	90.7-104.6	100-110
	480	18.4	25	18.4	25	18.4	25	18.4	25	14.9	15.0	27.1	30.0	43.3	45.0	52.3	60.0
	575	—								12.5	15.0	26.0	30.0	37.7	40.0	50.2	60.0
7.5	208-240	47.0	60	47.0	60	47.0	60	47.0	60	23.5-27.1	30-30	45.4-52.3	50-60	75.0-86.6	80-90	90.7-104.6	100-110
	480	22.7	25	22.7	25	22.7	25	22.7	25	14.9	15	27.1	30	43.3	45	52.3	60
	575	—								12.5	15	26	30	37.7	40	50.2	60
10	208-240	53.5	60	53.5	60	53.5	60	53.5	60	23.5-27.1	30-30	45.4-52.3	50-60	75.0-86.6	80-90	90.7-104.6	100-110
	480	26.6	30	26.6	30	26.6	30	26.6	30	14.9	15	27.1	30	43.3	45	52.3	60
	575	—								12.5	15	26	30	37.7	40	50.2	60
HIGH STATIC DRIVE (OPTIONAL): 5-HP 2-SPEED MOTOR WITH POWER EXHAUST (OPTIONAL)																	
12.5	208-240	66.4	80	66.4	80	66.4	80	66.4	80	23.5-27.1	30-30	45.4-52.3	50-60	75.0-86.6	80-90	90.7-104.6	100-110
	480	33.9	40	33.9	40	33.9	40	33.9	40	14.9	15	27.1	30	43.3	45	52.3	60

\*For C series units: Nominal unit input voltage = 208-230V/60-Hz/3PH, minimum allowed unit voltage = 187V, and maximum allowed voltage = 253V.

\*\*For D series units: nominal unit input voltage = 460V/60-Hz/3PH, minimum allowed unit voltage = 414V, and maximum allowed voltage = 506V.

\*\*\*To achieve the rated unit performance, unit voltage should be within 2% of nominal.

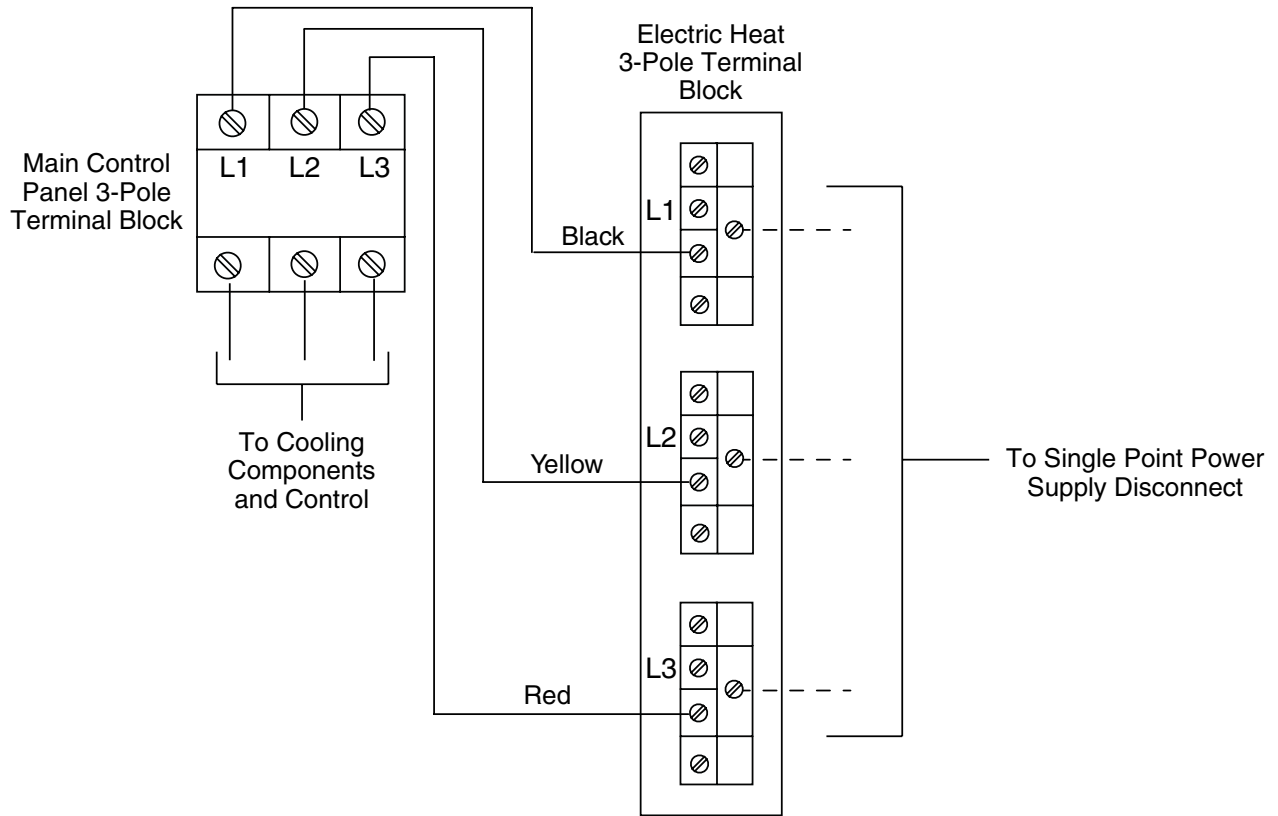
KEY: FLA = Full Load Amps, MCA = Minimum Circuit Ampacity, RLA = Rated Load Amps, MOP = Maximum Over-Current Protection, and LRA = Locked Rotor Amps.

**Table 5. MCA/MOP Data (Multiple Circuit)**



# Electrical Diagrams

## SINGLE BRANCH CIRCUIT POWER SUPPLY



## DUAL BRANCH CIRCUIT POWER SUPPLY

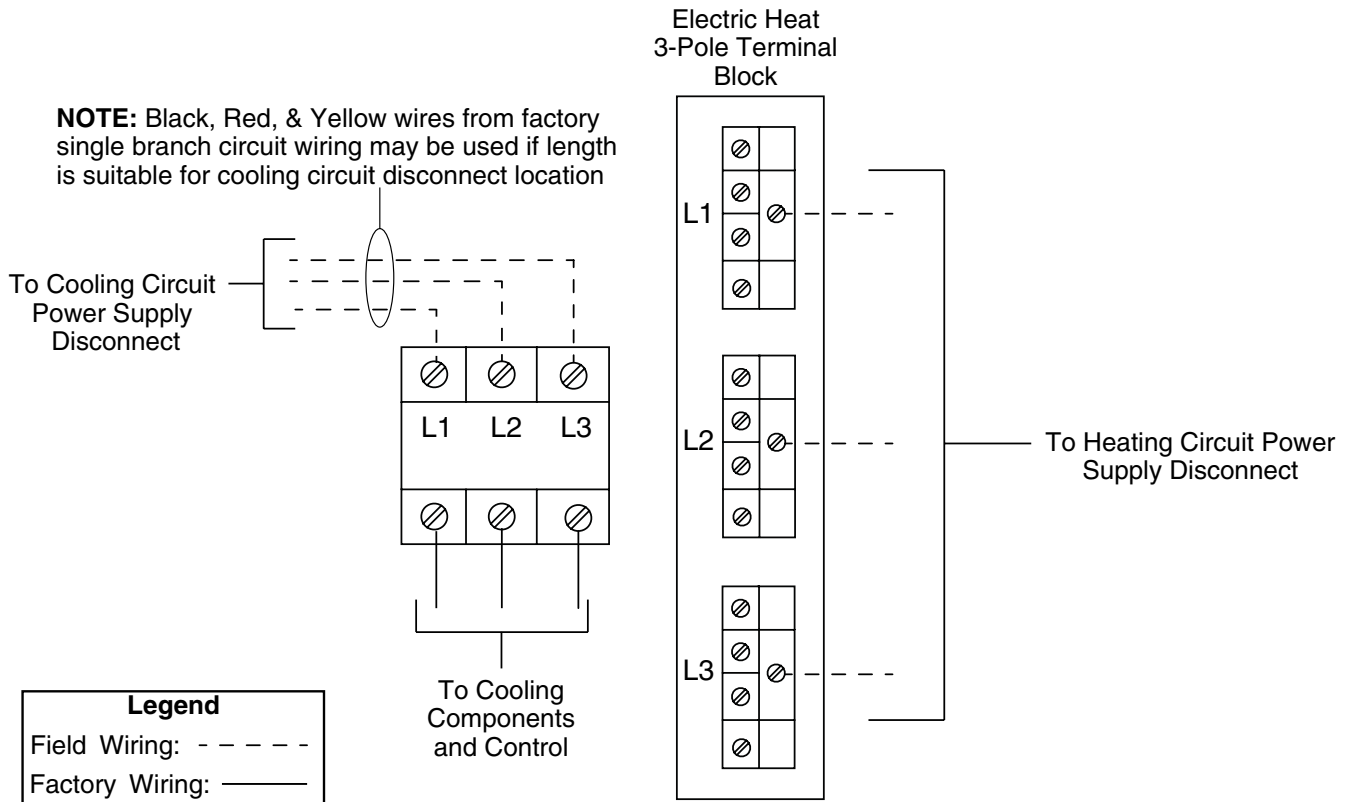


Figure 13. Single and Dual Power Supply Connections

# 9 kW, 1-Stage, 208 / 240 VAC, 3-Phase Heater Kit

85

86

87

88

89

90

91

92

93

94

95

96

97

98

99

100

101

102

103

104

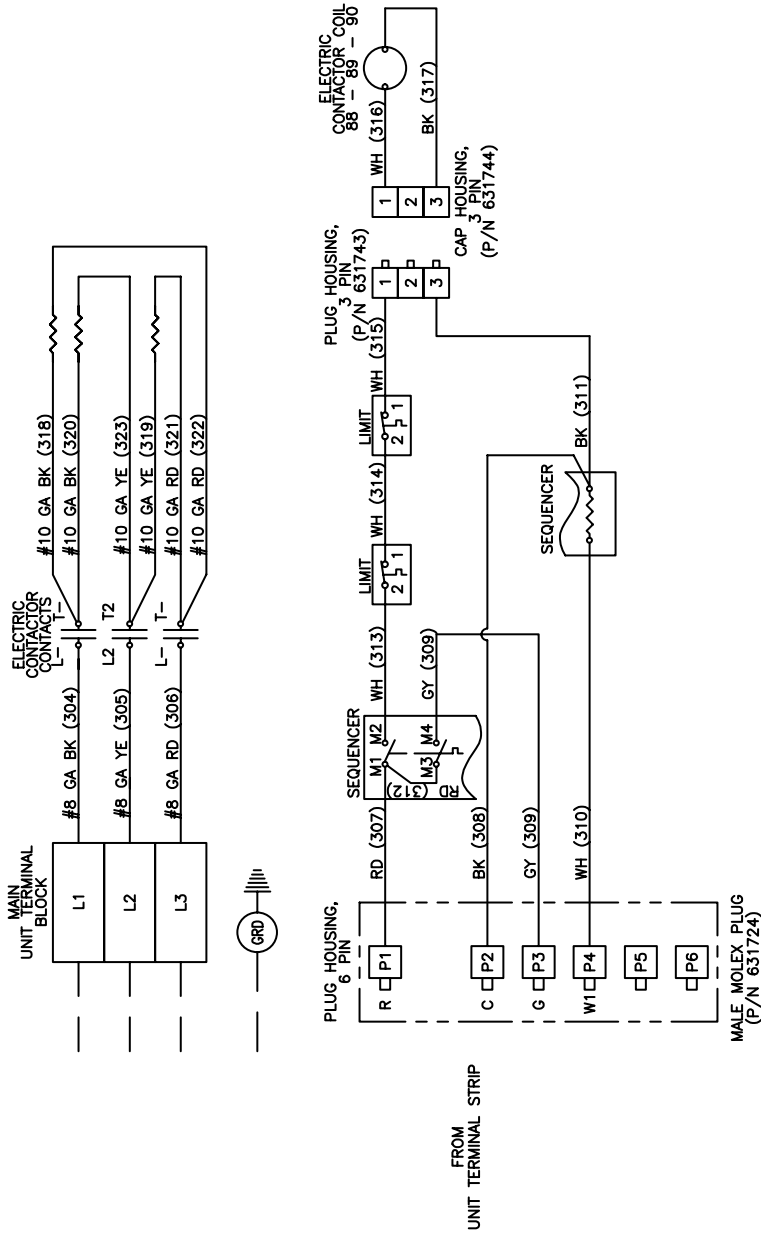
105

106

107

108

109



## NOTES

1. IF ANY OF THE ORIGINAL WIRE AS SUPPLIED WITH THE UNIT MUST BE REPLACED, IT MUST BE REPLACED WITH WIRING MATERIAL OF THE SAME GAUGE SIZE AND TEMPERATURE RATING.
2. USE COPPER CONDUCTORS WITH A MINIMUM TEMPERATURE RATING OF 60° C. FOR SUPPLY CONNECTIONS.



1012102A

(Replaces 10121020) (05/17)

Figure 14. Wiring Diagram for 9 kW, 240V, 3-Phase

# 9 kW, 1-Stage, 480 VAC, 3-Phase Heater Kit

85

86

87

88

89

90

91

92

93

94

95

96

97

98

99

100

101

102

103

104

105

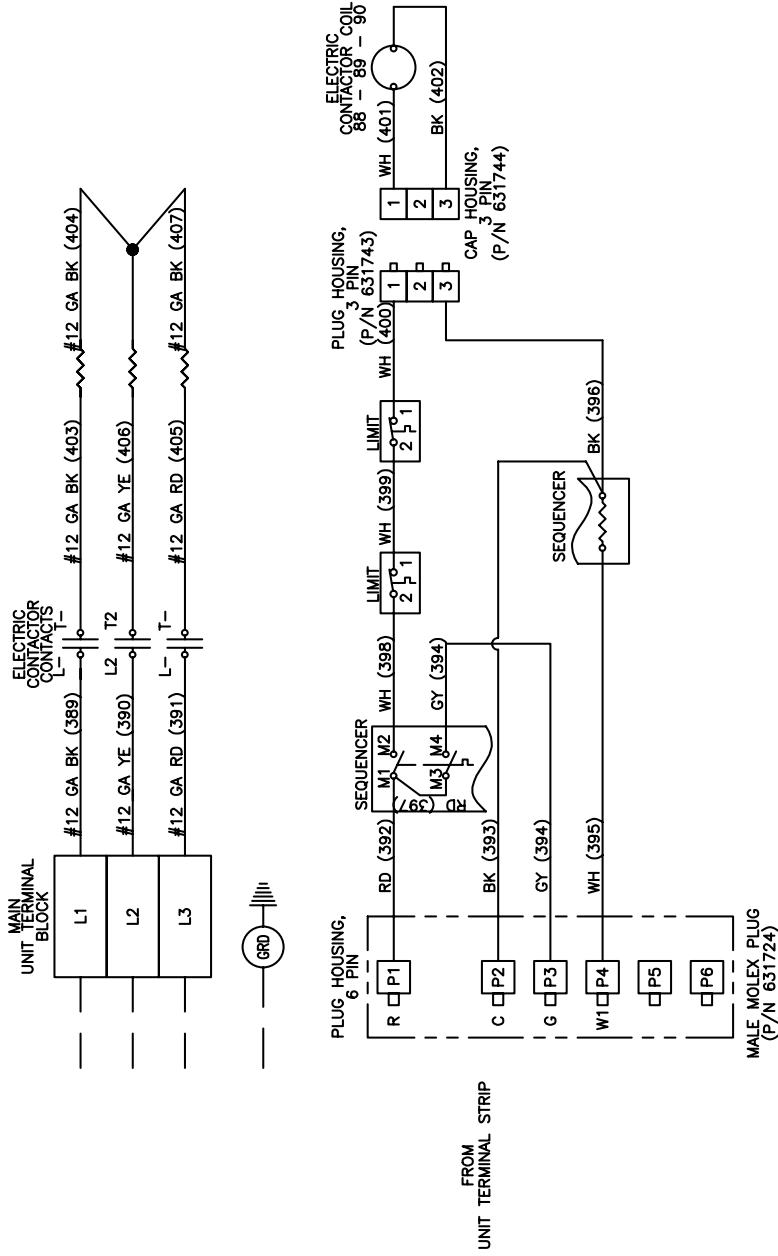
106

107

108

109

Figure 15. Wiring Diagram for 9 kW, 480V, 3-Phase



## NOTES

1. IF ANY OF THE ORIGINAL WIRE AS SUPPLIED WITH THE UNIT MUST BE REPLACED, IT MUST BE REPLACED WITH WIRING MATERIAL OF THE SAME GAUGE SIZE AND TEMPERATURE RATING.
2. USE COOPER CONDUCTORS WITH A MINIMUM TEMPERATURE RATING OF 60° C. FOR SUPPLY CONNECTIONS.



1012103A

(Replaces 10121030) (05/17)

# 10 kW, 1-Stage, 575 VAC, 3-Phase Heater Kit

100

101

102

103

104

105

106

107

108

109

110

111

112

113

114

115

116

117

118

119

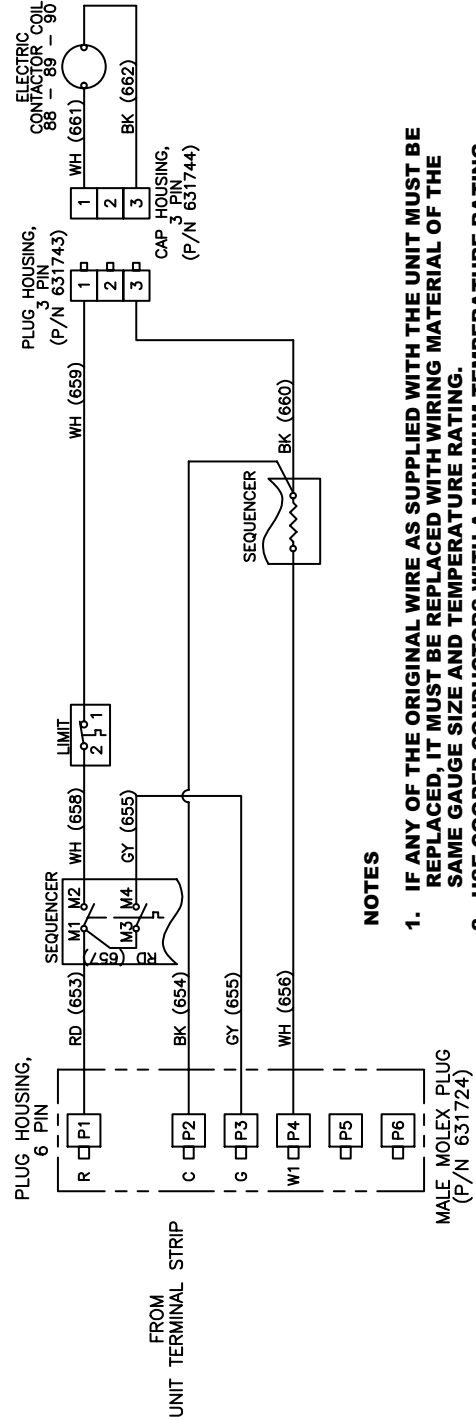
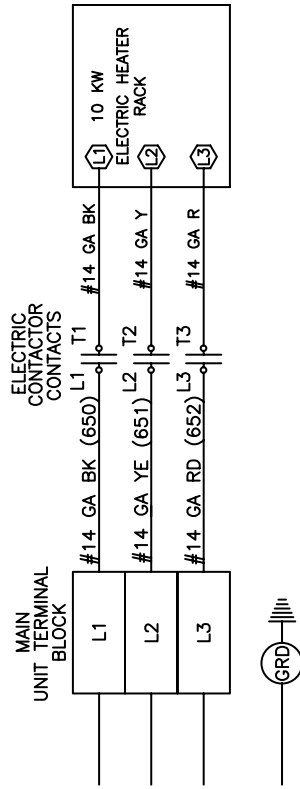
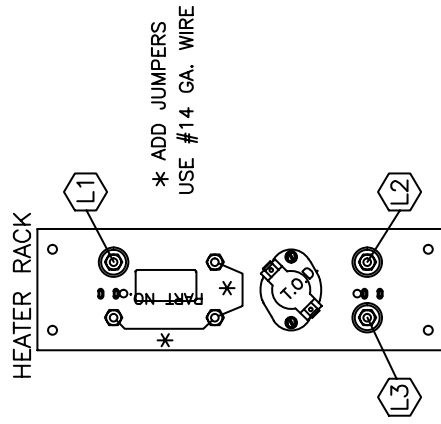
120

121

122

123

124



## NOTES

1. IF ANY OF THE ORIGINAL WIRE AS SUPPLIED WITH THE UNIT MUST BE REPLACED, IT MUST BE REPLACED WITH WIRING MATERIAL OF THE SAME GAUGE SIZE AND TEMPERATURE RATING.
2. USE COOPER CONDUCTORS WITH A MINIMUM TEMPERATURE RATING OF 60° C. FOR SUPPLY CONNECTIONS.

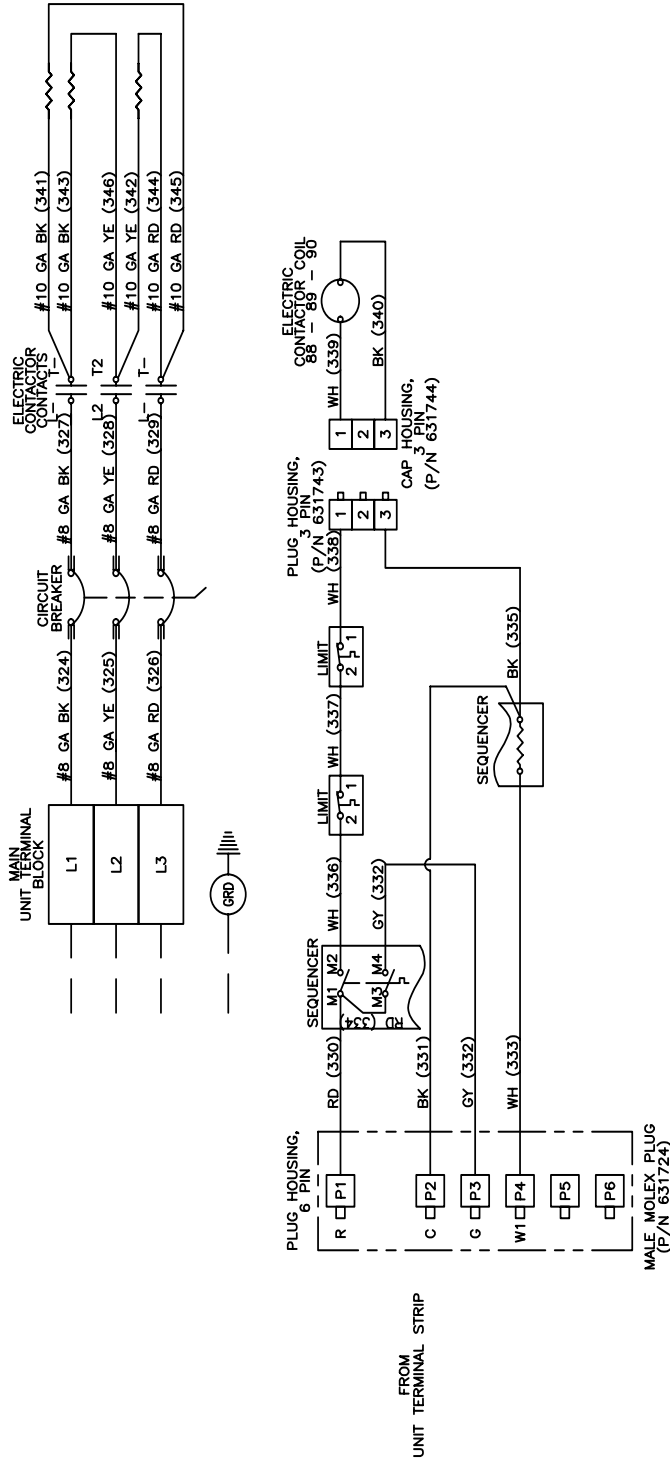


10121040  
(NEW) (05/17)

Figure 16. Wiring Diagram for 10 kW, 575V, 3-Phase

# 18 kW, 1-Stage, 208 / 240 VAC, 3-Phase Heater Kit

85  
86  
87  
88  
89  
90  
91  
92  
93  
94  
95  
96  
97  
98  
99  
100  
101  
102  
103  
104  
105  
106  
107  
108  
109



## NOTES

1. IF ANY OF THE ORIGINAL WIRE AS SUPPLIED WITH THE UNIT MUST BE REPLACED, IT MUST BE REPLACED WITH WIRING MATERIAL OF THE SAME GAUGE SIZE AND TEMPERATURE RATING.
2. USE COOPER CONDUCTORS WITH A MINIMUM TEMPERATURE RATING OF 60° C. FOR SUPPLY CONNECTIONS.



1012105A

(Replaces 10121050) (05/17)

Figure 17. Wiring Diagram for 18 kW, 240V, 3-Phase

# 18 kW, 1-Stage, 480 VAC, 3-Phase Heater Kit

85

86

87

88

89

90

91

92

93

94

95

96

97

98

99

100

101

102

103

104

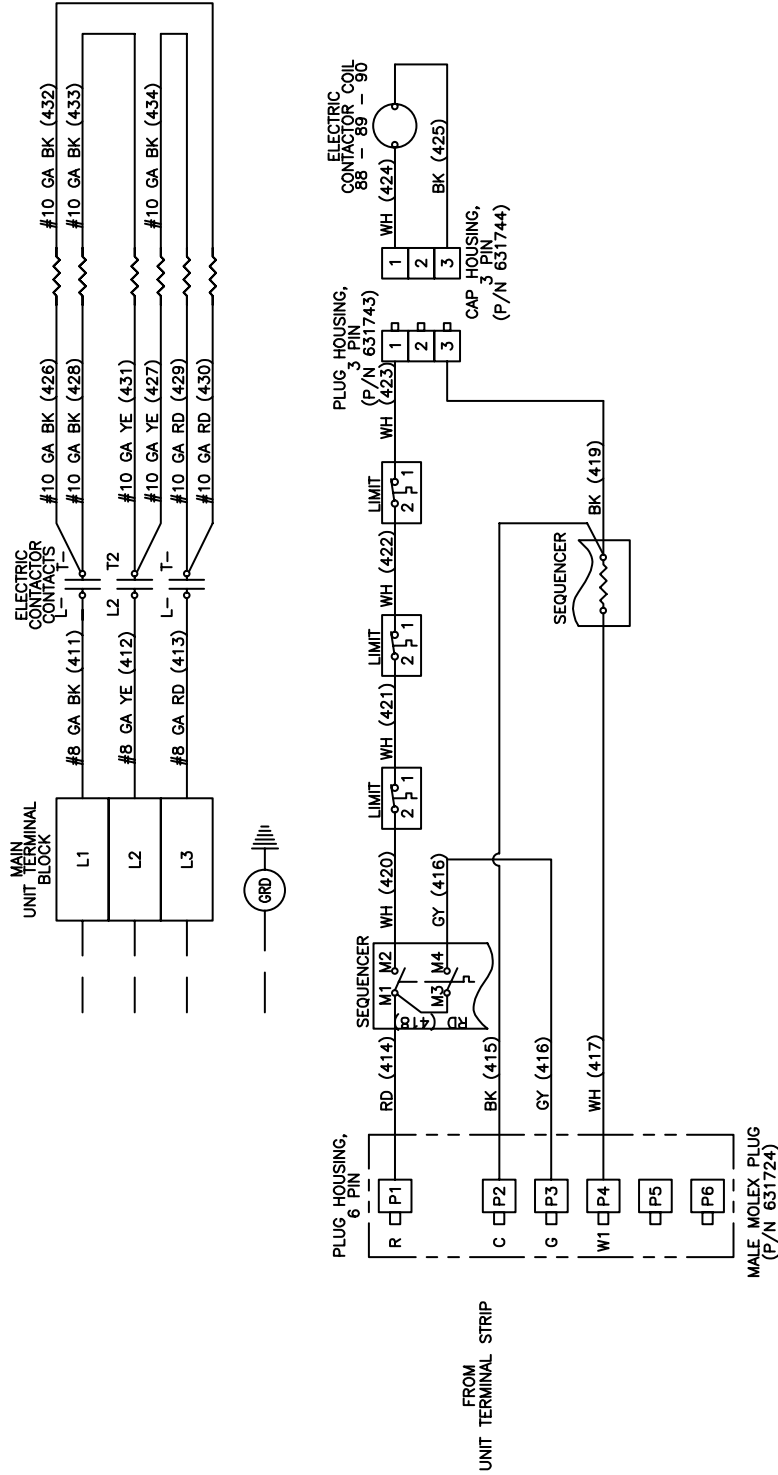
105

106

107

108

109



## NOTES

1. IF ANY OF THE ORIGINAL WIRE AS SUPPLIED WITH THE UNIT MUST BE REPLACED, IT MUST BE REPLACED WITH WIRING MATERIAL OF THE SAME GAUGE SIZE AND TEMPERATURE RATING.
2. USE COOPER CONDUCTORS WITH A MINIMUM TEMPERATURE RATING OF 60° C. FOR SUPPLY CONNECTIONS.



1012106A

(Replaces 10121060) (05/17)

Figure 18. Wiring Diagram for 18 kW, 480V, 3-Phase



# 30 & 35 kW, 1-Stage, 208 / 240 VAC, 3-Phase Heater Kit

85

86

87

88

89

90

91

92

93

94

95

96

97

98

99

100

101

102

103

104

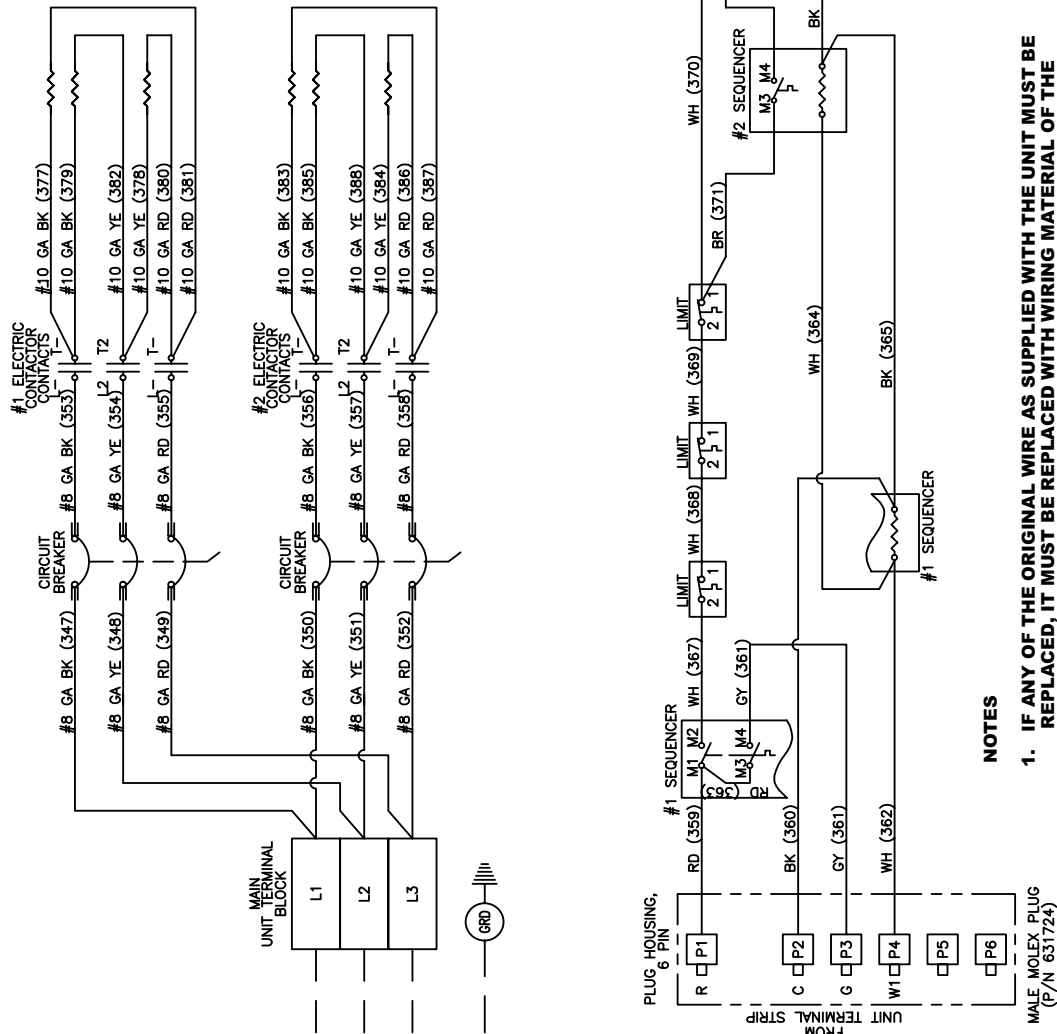
105

106

107

108

109



### NOTES

1. IF ANY OF THE ORIGINAL WIRE AS SUPPLIED WITH THE UNIT MUST BE REPLACED, IT MUST BE REPLACED WITH WIRING MATERIAL OF THE SAME GAUGE SIZE AND TEMPERATURE RATING.
2. USE COPPER CONDUCTORS WITH A MINIMUM TEMPERATURE RATING OF 60° C. FOR SUPPLY CONNECTIONS.

MALE MOLEX PLUG  
(P/N 631724)



1012108A

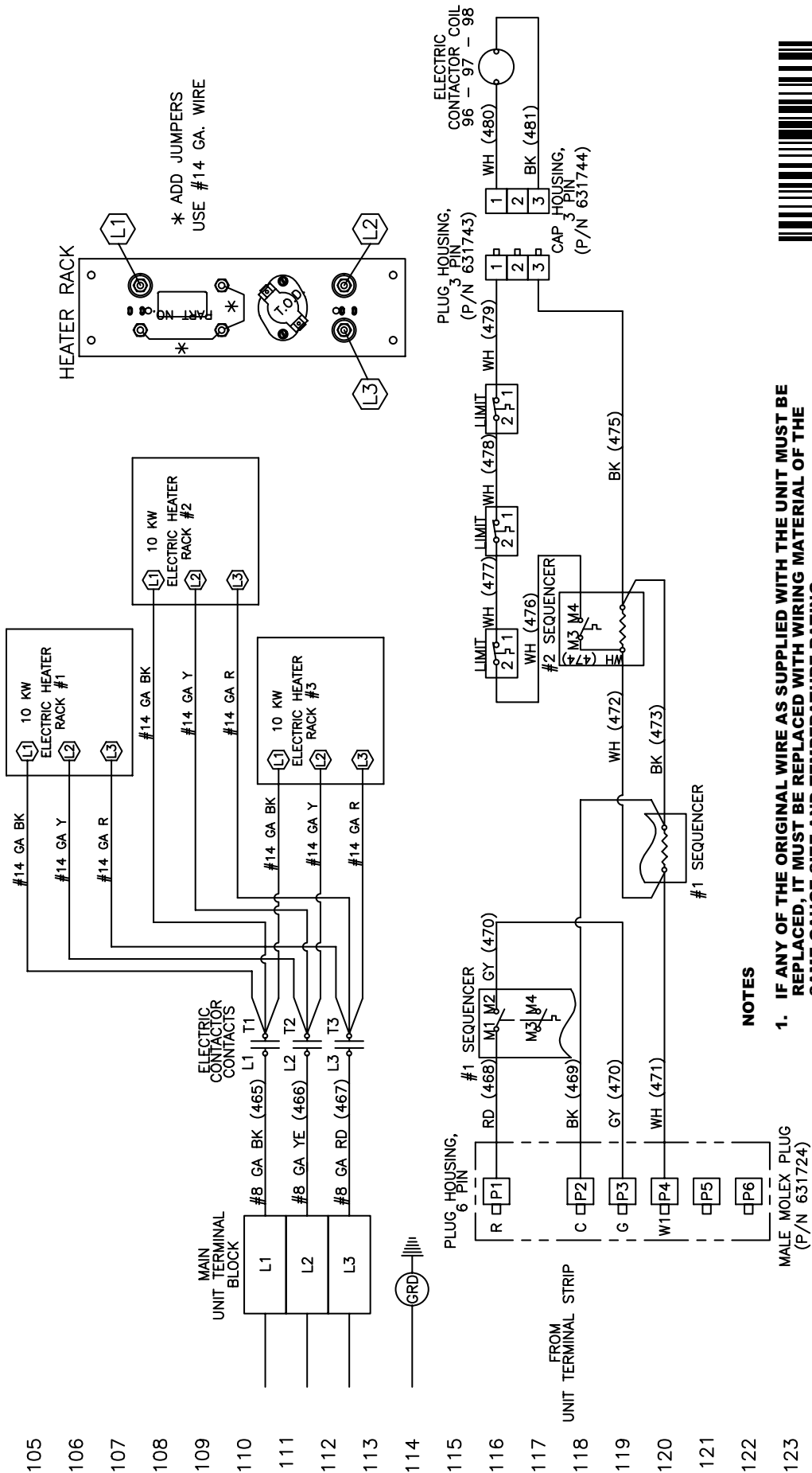
(Replaces 10121080) (05/17)

Figure 20. Wiring Diagram for 30 and 35 kW, 240V, 3-Phase





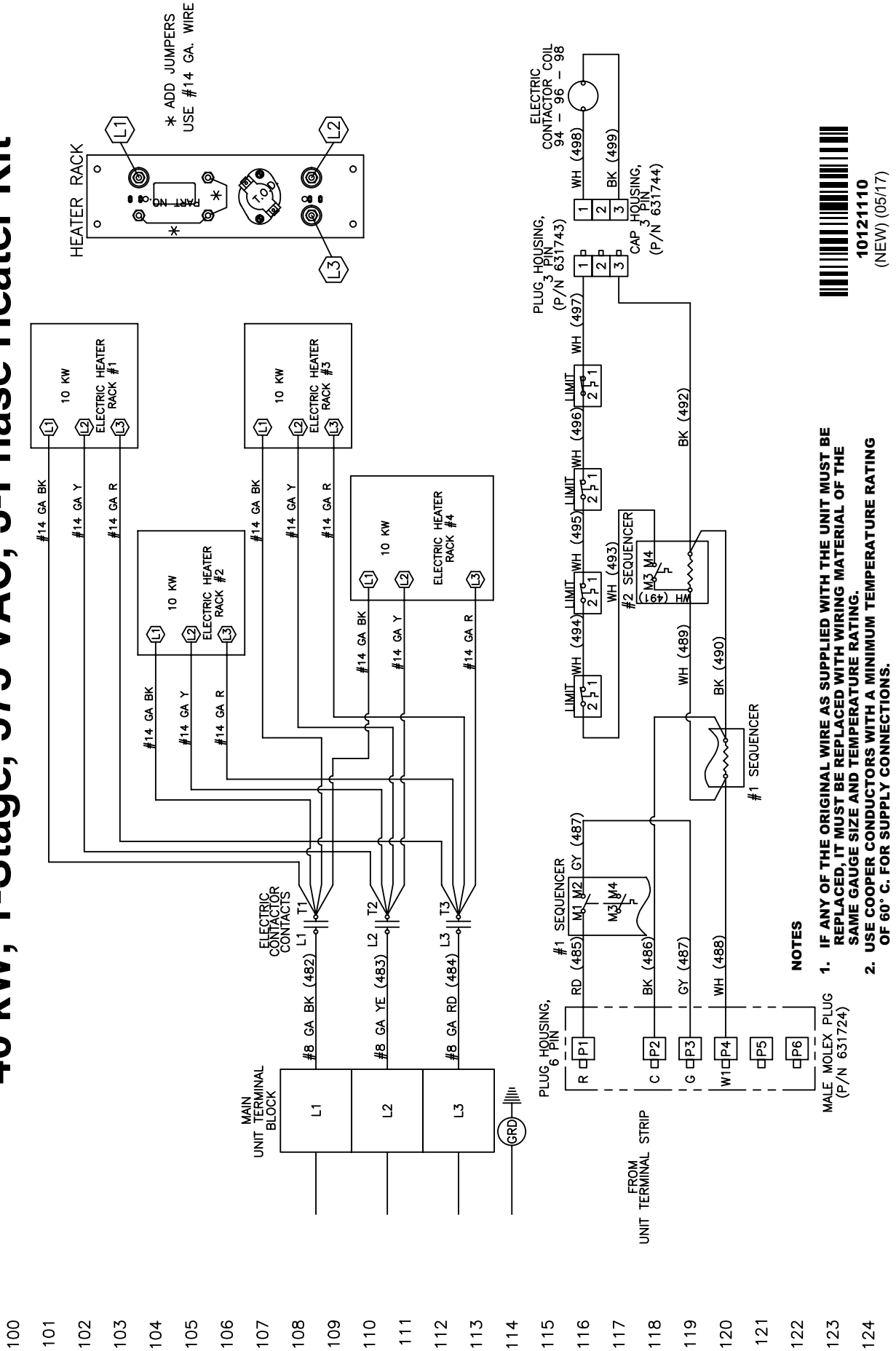
# 30 kW, 1-Stage, 575 VAC, 3-Phase Heater Kit



10121100  
(NEW) (05/17)

Figure 22. Wiring Diagram for 30 kW, 575V, 3-Phase

# 40 kW, 1-Stage, 575 VAC, 3-Phase Heater Kit



10121110  
(NEW) (05/17)

Figure 23. Wiring Diagram for 40 kW, 575V, 3-Phase



Intertek

**INSTALLER: PLEASE LEAVE THESE  
INSTALLATION INSTRUCTIONS WITH  
THE HOMEOWNER**

