

Instructions for Installing Replacement Gear Motor Kit

Applies: Modulating Gas Control Options AG39, AG40, AG41 & AG42 on Model Series SC & Model Series RP

Application / Components

This kit is designed to replace the solenoid actuator with a gear motor on heaters equipped with a modulating gas control Option AG39, AG40, AG41 or AG42. To facilitate replacement, the new flue duct, combustion air damper and gear motor is factory-assembled and wired for change out.

Gear Motor Replacement Kit includes a new factory-assembled flue duct and combustion air damper with a factory-wired gear motor installed plus three new replacement gaskets		Sizes 100, 125, 150, 175, 200, 225, 250, 300	Size 400
Kit P/N		208474	208475
Components:	Qty	P/N	P/N
Factory-assembled and Wire Flue Duct and Combustion Air Damper Assembly with Gear Motor (See FIGURE 1)	1	207975	207976
Cover Plate Gasket	1	41996	
Venter Seal Gasket	1	44695	
Flue Outlet Duct Gasket	1	31900	

FIGURE 1

Gear Motor Replacement Kit includes Factory-Assembled & Wired Flue Duct & Combustion Air Damper Assembly with Gear Motor, P/N 207975 or P/N 207976 & three Replacement Gaskets.

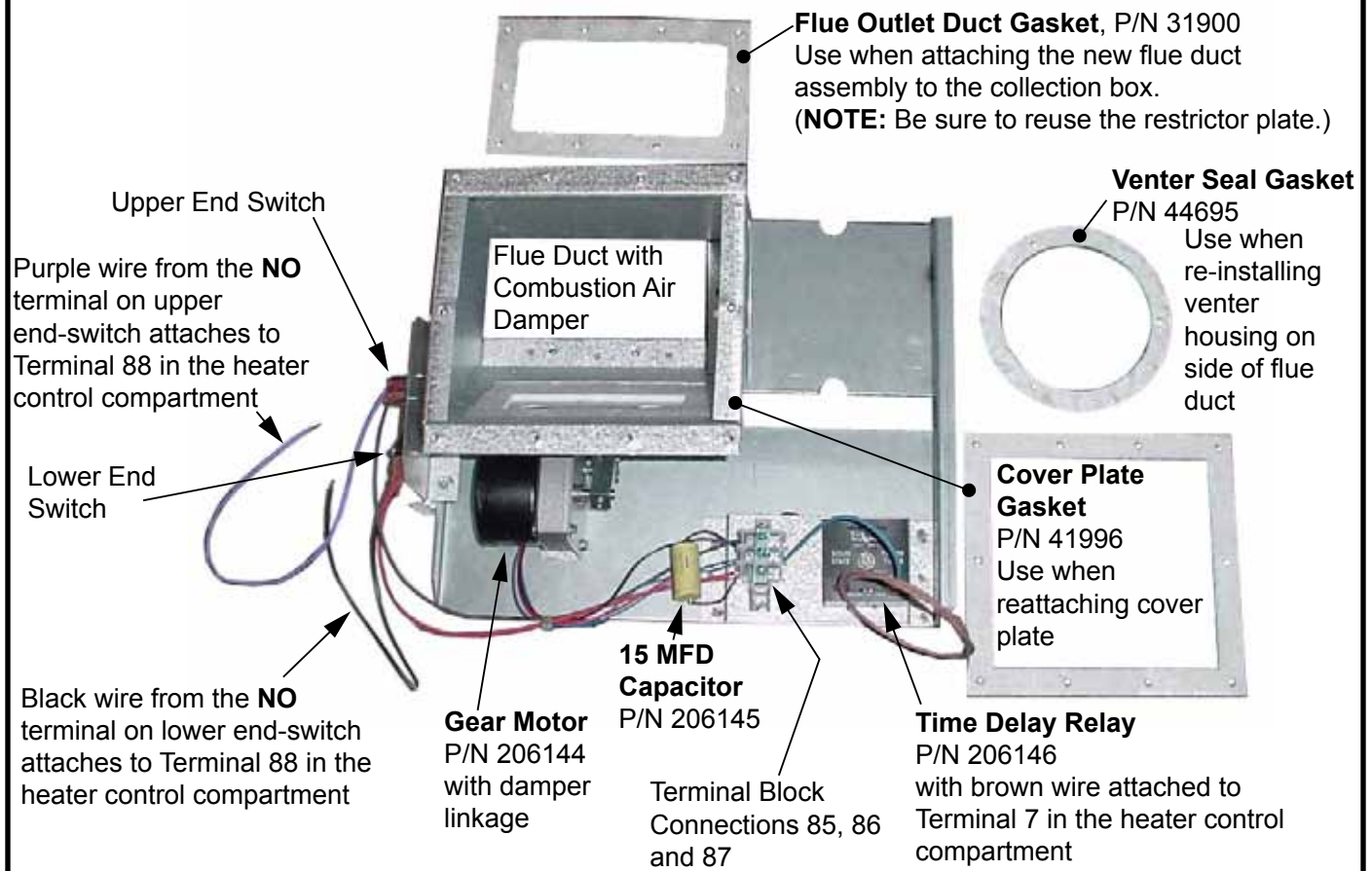

Warning: This replacement kit is to be installed by a qualified agency in accordance with these instructions and in compliance with all codes and requirements of authorities having jurisdiction. Failure to follow instructions could result in death, serious injury and / or property damage. The qualified agency performing this work assumes responsibility for this installation.

Instructions

Read carefully as many parts must be re-installed.

1. Turn off the gas supply at the shutoff valve upstream of the combination valve and turn off the electrical supply.
2. Remove the flue and combustion air damper with solenoid actuator as an assembly (See FIGURE 2):
 - a. On the outside of the cabinet, remove the two upper control access panels, revealing the control compartment, the venter assembly and the flue duct assembly. Carefully remove the venter motor and wheel assembly from the venter housing. Remove the venter housing.

(Model RP series only - Disconnect the rubber tubing from the sensing probe on the venter housing. Leave other end attached to the pressure switch). Save all venter parts including hardware, will be reused.
 - b. Disconnect Wires (Refer to original damper actuator wiring shown on page 4):
 - Disconnect and discard the black wire that connects the combustion damper actuator coil to Terminal C in the heater control compartment.
 - Disconnect and discard the white wire that connects the combustion damper actuator coil to Terminal L2 in the heater control compartment.
 - Disconnect the yellow wire at its connection on the combustion damper upper end-switch. (Leave the other end of the yellow wire connected to Terminal 87 in the heater control compartment. This yellow wire will be reused.)
 - Disconnect the orange wire at its connection on the combustion damper lower end-switch. (Leave the other end of the orange wire connected to Terminal 84 in the heater control compartment. This orange wire will be reused.)
 - Disconnect and discard the black wire that connects the combustion damper lower end-switch to Terminal 88.
 - c. Remove the flue duct cover plate from the flue duct and damper assembly.

Model SC Series only. - Disconnect the rubber tubing from the sensing probe on the flue duct cover plate.
 - d. Remove the flue duct, combustion air damper and solenoid actuator as an assembly. Remove the screws attaching the flue duct to the collection box and remove the assembly. See FIGURE 2. Keep the restrictor plate and all hardware. Discard the flue outlet duct gasket.

On Model SC Series heaters - Remove and keep the sensing probe that is attached to the side of the flue duct. Discard the remaining assembly illustrated in FIGURE 2.

FIGURE 2

Remove & discard the Flue Duct & Combustion Air Damper Assembly with Solenoid Actuator

- **Models RP & SC** - Keep the restrictor plate & all hardware. Discard the flue duct gasket.
- **Models RP & SC** - Keep the cover plate removed in Step 2c. Discard the cover plate gasket.
- **Model SC** - Remove & keep the sensing probe attached to the side of the flue duct.

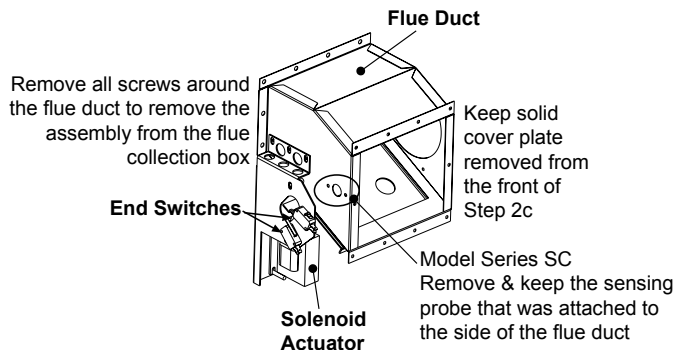

Assembly removed from a unit manufactured prior to 8/2001

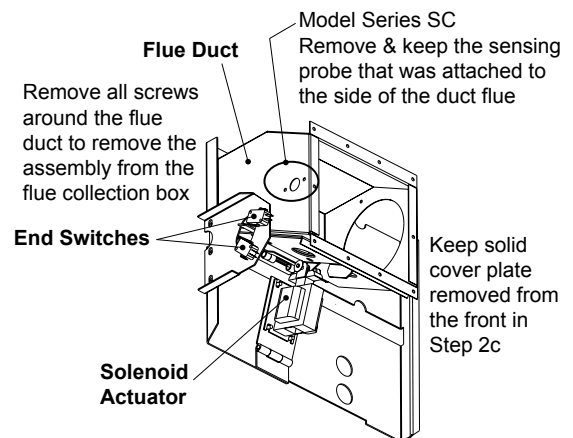

Assembly removed from a unit manufactured beginning 8/2001

FIGURE 3

Side view of Flue Duct Assembly showing Combustion Damper End-Switches

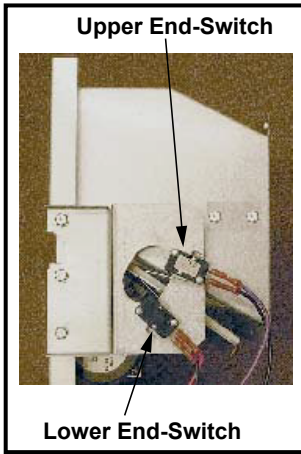

FIGURE 4

Top view of Combustion Damper End-Switches showing Damper Adjustment Screws

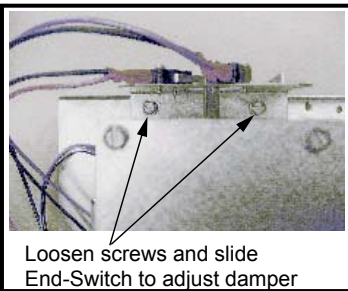
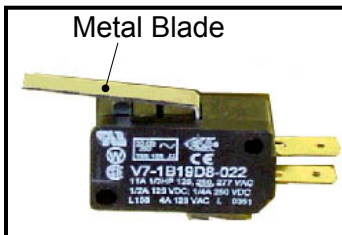

FIGURE 5

End-Switch



3. Install the replacement flue duct & damper assembly with gear motor:

- a. Using the new flue outlet duct gasket from the kit and the restrictor plate removed in Step 2d, attach the new flue duct and combustion air damper with gear motor assembly to the heater.

Model SC Series heaters - On the side of the flue duct in the new assembly, remove the patch plate to attach the sensing probe removed in Step 2d. Slide the long sensing tube through the hole and position it so that the tube will extend into the round venter opening on the side of the flue duct. Use the screws that had held the patch plate to attach the sensing tube plate to the flue duct. Slide the rubber tubing (attached to the pressure switch) over the metal tubing on the side of the flue duct. Be sure tubing is secure.

- b. Using the new cover plate gasket, attach the flue duct cover plate removed in Step 2c to the front of the newly installed flue duct and combustion air damper assembly.
- c. Using the new venter seal gasket and orifice plate removed with the venter housing, re-install the venter housing. Carefully re-attach the venter motor and wheel assembly.

Model RP Series heaters - Slide the rubber tubing (attached to the pressure switch) onto the sensing probe on the venter housing. Be sure that the tubing is secure.

- d. Connect the wires. (Refer to the Replacement Gear Motor Diagram on page 4; **FIGURE 1** on page 1 & **FIGURE 3** on this page):

- Connect the yellow wire from heater control compartment Terminal 87 to the common terminal of the new combustion damper upper-end switch.
- Connect the orange wire from the heater control compartment Terminal 84 to the common terminal of the new combustion air damper lower end-switch.
- Connect the purple wire from the normally-open terminal of the new combustion air damper **upper** end-switch to Terminal 88 in the heater control compartment.
- Connect the black wire from the normally-open terminal of the new combustion air damper **lower** end-switch to Terminal 88 in the heater control compartment.
- Connect the brown wire from the motor run time delay relay to Terminal 7 in the heater control compartment.

4. Check Operation:

- a. Turn on the electric and the gas.
- b. Set the system control to “call” for heat.
- c. Vary the control settings and observe for proper opening and closing of the damper. The gear motor was factory set to fully close the damper and to open it with approximately 1-1/8” (29mm) between the upper edge of the damper and the duct assembly. If the damper door does not fully close or open properly, loosen the adjusting screws as shown in **FIGURE 4** and slide the end-switch back and forth until proper operation is obtained. If necessary, carefully bend the metal blade (**FIGURE 5**).
- d. After it is determined that the newly installed combustion air damper is operating correctly, replace the access panels. Check for proper operation of the heater.

Keep the Field Replacement Gear Motor Wiring on page 4 with the original heater wiring diagram.

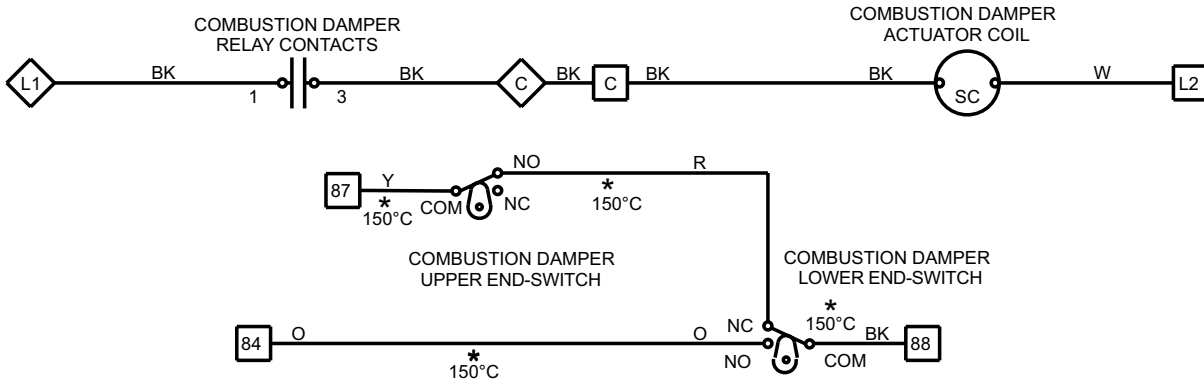

ORIGINAL DAMPER ACTUATOR WIRING (TYPICAL)

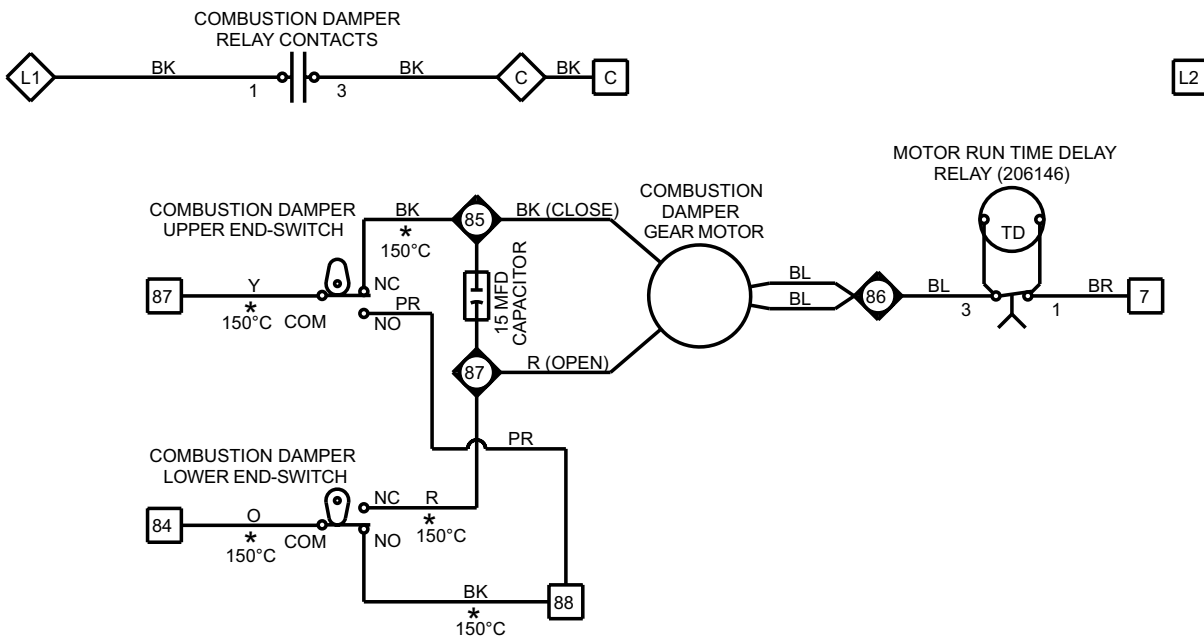

FIELD REPLACEMENT GEAR MOTOR WIRING



WIRING CODE
 BLACK - BK
 BROWN - BR
 RED - R
 ORANGE - O
 YELLOW - Y
 GREEN - G
 BLUE - BL
 PURPLE - PR
 WHITE - W

- 85, 86 & 87  TERMINAL BLOCK -- FLUE DUCT / DAMPER / GEAR MOTOR ASSEMBLY
- C & L1  TERMINAL BLOCK -- BLOWER COMPARTMENT (CERTAIN MODELS)
- 84, 87, 88, C & L2  TERMINAL BLOCK -- HEATER CONTROL COMPARTMENT

**REPLACEMENT GEAR MOTOR WIRING
 MUST BE KEPT WITH
 ORIGINAL WIRING DIAGRAM**

Specifications & illustrations subject to change without notice and without incurring obligations.
 ©Nortek Global HVAC, LLC 2016. All rights reserved.
 All marks are the property of their respective organizations.
 O'Fallon, MO | Printed in U.S.A. (6/16)
 FORM CP-OPT-GMK (6-16), PN208831 R3