

**WARNING: Improper installation, adjustment, alteration, service or maintenance can cause property damage, injury or death. Read the installation, operation, and maintenance instructions thoroughly before installing or servicing this equipment.**

**REZNOR®**

## Description

Option CQ3, Low Ambient Fan Control Relay Kit, is designed to prevent false cycling of the fan/blower on the unit heaters installed in areas with ambient temperature of less than 40°F. When the room temperature is below 40°F, the standard temperature-activated fan control may be cooled enough by the initial airflow to cause the fan/blower to shut off. Since the burner is still lit, the fan control will be reheated causing the fan/blower to cycle on and off.

The optional time delay relay is actuated electrically, independent of room temperature or heat exchanger temperature. On heater start-ups, the time delay relay will start the fan/blower in about 45 seconds. On heater shutdown, the time delay will continue to operate the fan/blower for about 60 seconds to cool the heat exchanger. If the ambient temperature in the room is increased during heater operation, the fan control will act to keep the fan/blower on longer, until the heat exchanger is adequately cooled.

**IMPORTANT:** Do not remove the fan control from the heater circuit. The fan control is a safety device.

The Option Package (P/N 113779) includes:

Qty	P/N	Description
1	114007	Time Delay Relay Assembly (consisting of a time delay relay, Thermodisc #305055, P/N 97479, and four wire assemblies)
2	82485	Screws, #4 x 3/8" long (for attaching relay assembly)
1	16354	Wire Nut
1	98117	Open/Closed Bushings (required for units with lower horizontal partition; not required on units with cable holders - See Figure 1)

### Option CQ3, Low Ambient Fan Control Relay Kit



## OPTION CQ3 LOW AMBIENT FAN CONTROL RELAY

INSTALLATION FORM I-F/B-LA (01-15)  
Obsoletes Form RZ-NAI-F/B-LA

APPLIES TO: Models F, FE, B, BE with a Single-Stage Gas Valve

## Installation Instructions

Installation should be done by a qualified agency in accordance with these instructions and in compliance with all codes and requirements of authorities having jurisdiction.

1. If the heater is installed, turn off the gas and electric power.
2. Remove the outer side panel on the left side of the heater (left when facing the back of the heater), exposing the inner side panel and wiring.
3. On the vertical partition of the inner side panel, there are three locations with holes for mounting relays. The relay in this kit is designed to attach at the top set of holes (See Figure 1). Position the relay on the electrical compartment side of the vertical partition. Attach, using the smaller holes and the screws provided.

**Figure 1 - Location for Mounting Low Ambient Fan Control Relay**

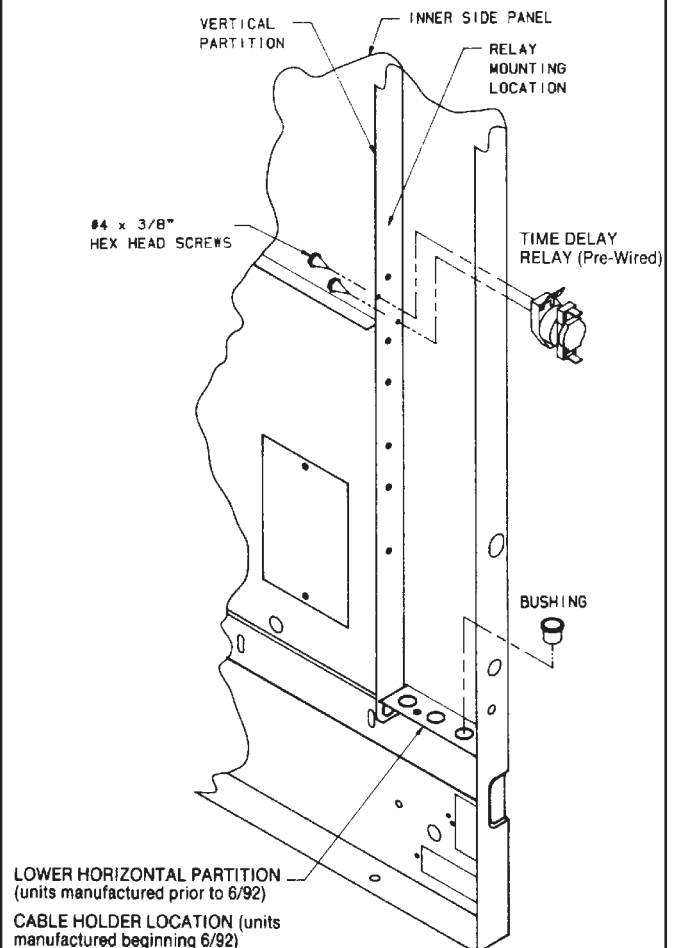

## Installation Instructions (cont'd)

4. **Electrical Wiring** – Route the brown and orange wire down through either the vacant hole (See Figure 1) in the horizontal partition or the cable holder. If the heater has a metal partition, insert the open/closed bushing included in the kit.

In order to connect the orange wire to the factory wires, it will be necessary to remove a factory-installed crimp terminal. See the original wiring portion (left side) of the wiring diagram in Figure 2.

Locate and cut off the crimp terminal. Strip the yellow and black factory-installed wires. Using the wire nut in the kit, connect the new orange wire with the yellow and black wires.

Connect the brown wire to the ground terminal on the heater terminal strip.

Connect the new black wires shown on the relay portion (right side) of the wiring diagram in Figure 2.

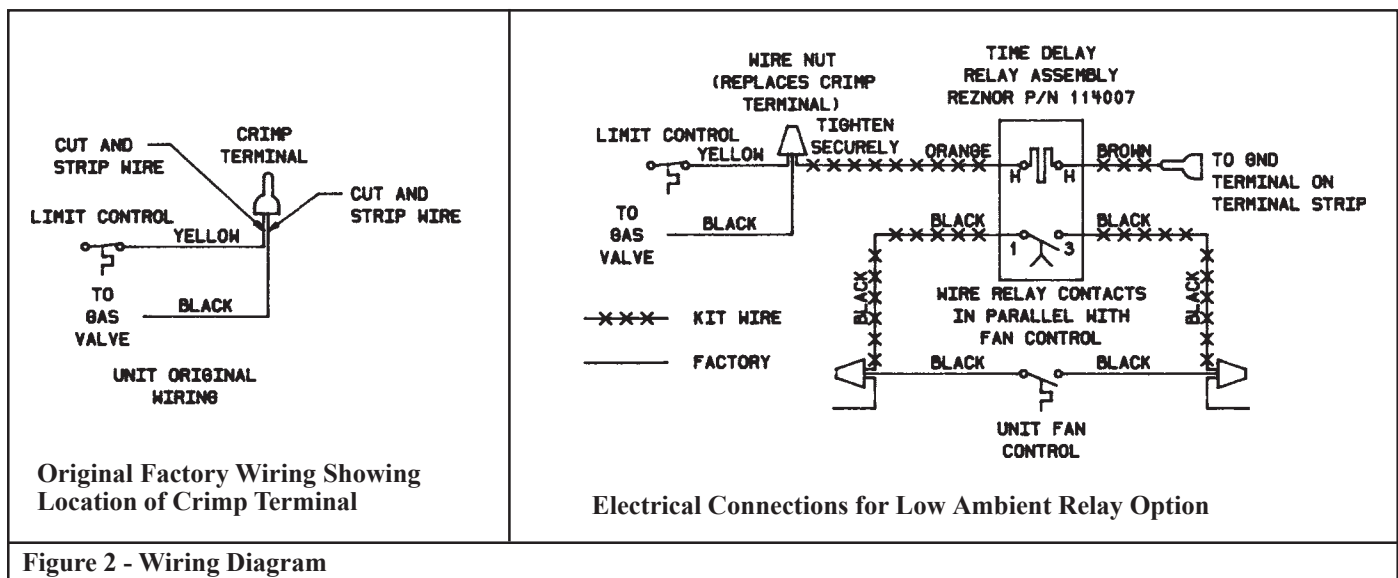

5. Replace heater side panel.
6. If the heater is installed, turn on the electric power and the gas. Re-light the heater following the instructions on the lighting instruction plate. Check the operation of the fan control. CHECK FOR PROPER OPERATION OF ALL SAFETY FEATURES.

If the heater is not installed, be sure to support the bottom with plywood or other appropriate material. Follow the installation instructions provided with the heater and check for proper operation of the controls.