

Gas-Fired, Balanced-Flue or Power-Vented Unit Heater

LCSA-3



Installation, commissioning, servicing & user instructions



These appliances meet the following EC Directives

DIR 2009/142/EC: GAD

DIR 2004/108/EC: EMC

DIR 2006/95/EC: LVD

DIR 2006/42/EC MD

Applies to

Austria, Belarus, Bulgaria, China, Czech Republic, Croatia, Cyprus, Denmark, England, Estonia, Finland, Germany, Greece, Hungary, Iceland, Latvia, Lithuania, Montenegro, New Zealand, Norway, Poland, Romania, Russian Federation, Serbia, Slovakia, Slovenia, South Africa, Spain, Sweden, Turkey, Ukraine

WARNING

Improper installation, adjustment, alteration, service or maintenance can cause property damage, injury, or death. All work must be carried out by appropriately qualified persons.

The manufacturer does not take any responsibility in the event of non-observance of the regulations concerning the connection of the apparatus causing a dangerous operation of the apparatus, possibly resulting in damage to the apparatus and/or environment in which the unit is installed.

Please read this document carefully before commencing installation commissioning and/or servicing.

Leave it with the user or attached to the appliance or gas service meter after installation.

Subject to modifications

TABLE OF CONTENTS

1.0 INTRODUCTION

- 1.1 Basic Information
- 1.2 Warranty

2.0 TECHNICAL DATA

- 2.1 Specifications
- 2.2 Dimensions

3.0 GENERAL REQUIREMENTS

- 3.1 Related Documents
- 3.2 Heater Location
- 3.3 Combustion Air Inlet Pipe and Flue Pipe
- 3.4 Air Supply
- 3.5 Air Distribution System
- 3.6 Electrical Supply
- 3.7 Gas Supply

4.0 INSTALLATION

- 4.1 Uncrating and Preparation
- 4.2 Suspending the Heater
- 4.3 Fitting the Combustion Air Inlet/Flue Pipe System
 - 4.3.1 Fitting the Flue Pipe
 - 4.3.2 Fitting the Combustion Air Socket Guard - Type B Installation
 - 4.3.3 Fitting the Combustion Air Pipe - Type C Installation
- 4.4 Gas Connection
- 4.5 Electrical Connections
- 4.6 Room Thermostat Siting

5.0 AIR DISTRIBUTION

6.0 COMMISSIONING AND TESTING

- 6.1 Electrical Check
- 6.2 Gas Connection
- 6.3 Suspension and Support
- 6.4 Lighting the Heater
 - 6.4.1 To Turn the Heater ON
 - 6.4.2 To Turn the Heater OFF for Short Periods
 - 6.4.3 To Turn the Heater OFF for Long Periods
- 6.5 Heater pipe work
- 6.6 Adjustments
- 6.7 Air Distribution System
- 6.8 Heater Controls
- 6.9 Handing Over

7.0 SERVICING INSTRUCTIONS

8.0 REMOVAL AND REPLACEMENT OF PARTS

- 8.1 Main Burner Removal
- 8.2 Main Burner Injectors
- 8.3 Ignition System
- 8.4 Operating Gas Valve
- 8.5 Limit Controls
- 8.6 Combustion Air Pressure Switch
- 8.7 Combustion Air Fan

9.0 FAULT FINDING

10.0 PARTS LIST

11.0 GAS CONVERSION

12.0 USERS INSTRUCTIONS

13.0 HEALTH & SAFETY STATEMENT

HAZARD INTENSITY LEVELS

 danger	DANGER Failure to comply will result in severe personal injury or death and/or property damage.
	WARNING Failure to comply could result in severe personal injury or death and/or property damage.
	CAUTION Failure to comply could result in minor personal injury and/or property damage.



WARNING: The electrical isolator should only be used in an emergency and should not be used for closing down the main burner, as it switches off the fan prematurely and may damage the heat exchanger, invalidating the warranty.

Attention :

This appliance is not intended for use by persons (including children) with reduced sensory or mental capacities, or lack of experience and knowledge, unless they have been given supervision or instruction concerning use of the appliance by a person responsible for their safety. Children should be supervised to ensure that they do not play with the appliance.

1 INTRODUCTION

1.1 Basic Information

The instructions in this manual apply to Model LCSA-3 gas-fired/fan-assisted warm air heaters. These models have an axial fan for air delivery. These heaters are designed for overhead suspension and are suitable for indoor installation only installed at an operation ambient temperature between -15°C and 45°C. When installed as a type C12/C32 and where the height above floor level is greater than 1.8 meters measured to the underside of the appliance they may be used as a garage air heater. This appliance must be installed in accordance with the rules in force. Before installation, check that the local distribution conditions, nature of gas and pressure and adjustment of the appliance are compatible.

A permanent electricity supply of 230 volts, 50 Hz, single phase is required.

Heaters are approved for:

Type C₁₂ - horizontal vent for balanced-flue heaters;

Type C₃₂ - vertical vent for balanced-flue heaters;

Type B₂₂ - vertical vent;

When the external control calls for heat, an electronic control begins the ignition sequence to provide for a safe start. About 30 seconds after the call for heat, the fan will begin circulating warm air. The electronic control will supervise the flame during the entire heating cycle to ensure safe operation. When the required room temperature is reached, the main burner will shut down leaving the fan running to cool down the heat exchanger. After approximately 45 seconds, the fan delay relay will turn off the fan.

1.2 Warranty : Warranty is void if:

- LCSA-3 heaters are installed in atmospheres containing flammable vapors or atmospheres containing chlorinated or halogenated hydrocarbons or atmospheres containing any silicone, aluminum oxide, etc., that adheres to spark ignition flame sensing probes.
- The installation is not in accordance with these instructions.
- Axial fan-type unit heater is connected to a duct system or fitted with a non-authorized air distribution device.

2.1 Specifications

Table 1a

LCSA		12-3	20-3	30-3	35-3	45-3	50-3	60-3	75-3	100-3	120-3	145-3
Gas category		see table 1B										
Comb. Air & Flue, type B ⁽¹⁾		B22P										
Comb. Air & Flue, type C ⁽¹⁾		C12, C32, C42, C62										
Connection collars	mm	80	100	100	130	130	130	130	130	130	130	130
Heat input Hs	kW	13,33	26,42	31,63	43,95	54,38	61,08	73,25	87,85	114,87	144,81	165,47
Heat input Hi	kW	12,00	23,80	28,50	39,60	49,00	55,00	66,00	79,15	103,50	130,40	149,00
Heat output	kW	11,14	21,82	25,99	36,23	44,64	50,77	60,92	73,13	94,50	119,32	137,39
Thermal Efficiency	%	92,80	91,70	91,20	91,50	91,10	92,30	92,30	92,39	91,30	91,50	92,20
Gas consumption G20	m ³ /h	1,27	2,52	3,02	4,19	5,19	5,82	6,98	8,38	10,95	13,80	15,77
Gas consumption G31	kg/h	NA	1,86	2,22	3,09	3,82	4,29	5,15	6,17	8,24	10,17	11,62
Gas consumption Lw (20mbar) (*)	m ³ /h	NA	3,07	3,68	5,11	6,32	7,10	NA	10,22	NA	NA	NA
Gas consumption Ls (13mbar) (*)	m ³ /h	NA	3,50	4,19	5,82	7,20	8,08	NA	11,63	NA	NA	NA
Gas pipe connection ⁽²⁾		1/2"				3/4"						
Real temperature rise ⁽³⁾	K	30	31	33	33	31	30	34	29	34	32	35
Air flow measured ⁽³⁾	m ³ /h	1100	2045	2326	3170	4270	5012	5214	7282	8024	10764	11400
Nominal motor speed	RPM	1381	1256	1333	1300	1310	928	1346	1344	935	872	875
Recommended mounting height ⁽⁴⁾	m	2,5	3	4	4	4	4	5	5	5	6	6
Horizontal throw ⁽⁵⁾	m	9,5	13	17	24	25	27	30	32	31	38	39
Sound Pressure ⁽⁶⁾	dB(A)	36	42	47	48	48	45	54	55	53	54	55
Sound Pressure ⁽⁷⁾	dB(A)	43	49	54	55	55	52	61	62	60	61	62
Electrical service (protection IP20)		230/240V 1N ~ 50Hz										
Total electrical rating	W	533	363	533	723	723	543	1233	1233	993	723	723
Weight	kg	59	59	64	94	99	114	114	126	184	242	279

(*) - only for Poland

(1) Gas Appliance Classifications for Approved Venting Methods based on CEN-report CR 1749:2001

(2) There is a difference between the gas connection diameter and the diameter of the supply line. Always use the most adequate diameter of the supply line to minimize the pressure drop through the gas pipes - if necessary, reduce the diameter of the supply line at the inlet of the unit.

(3) Figure for isothermal conditions.

(4) Height from floor to bottom surface of heater. These are recommendations only. Positioning of unit heaters for proper performance is application dependent. Care should be taken to avoid mounting the heaters above these recommendations, unless downturn nozzle options are used, as significant stratification may occur resulting in poor floor coverage and higher energy losses through the roof structure.

(5) Isothermal conditions at 20°C ambient air temperature, discharge louvre zero deflection, v = 0,5 m/s. The air throw will be influenced by the height of the building, mounting height of the unit, ambient temperature & adjustment of the louvres.

(6) Sound pressure level in dB(A) in free field conditions, measured at 5 metres from the unit

(7) Sound pressure level in dB(A), measured at 5 metres from the unit with A=160m² and Q=2

Table 1b : Gas categories

Country	Gas category
Austria	I12H3P
Belarus	I12H3+
Bulgaria	I2H or I3P
China	I12H3+
Czech republic	I12H3+
Croatia	I12H3P
Cyprus	I12H3+
Denmark	I12H3 B/P
England	I12H3+
Estonia	I12H3+
Finland	I12H3 B/P
Germany	I2ELL
Greece	I12H3+
Hungary	I12HS3P
Iceland	I12H3+
Latvia	I12H3+
Lithuania	I12H3+

Country	Gas category
Montenegro	I12H3+
New Zealand	I12H3+
Norway	I12H3 B/P
Poland	I12E3P
Portugal	I12H3+
Romania	I12H3 B/P
Russian Federation	I2H or I3P
Serbia	I12H3+
Slovakia	I12H3+
Slovenia	I12H3+
South Africa	I12H3+
Spain	I12H3+
Sweden	I12H3 B/P
Turkey	I12H3+
Ukraine	I2H or I3P

Table 2 :Injector size and burner pressures

Belarus, China, Croatia, Czech Republic, Cyprus, England, Estonia, Greece, Iceland, Latvia, Lithuania, Montenegro, New Zealand, Portugal, Serbia, Slo
Slovakia, South Africa, Spain , Turkey, Poland

LCSA-3		Model	12	20	30	35	45	50	60	75	100	120
Nat. Gas G20	Injector	quantity	5	5	6	8	10	8	8	10	12	10
	Injector size	mm	1,50	2,10	2,10	2,20	2,20	2,40	2,70	2,70	2,90	3,40
		marking	150	210	210	220	220	240	270	270	290	340
	Burner pressure (1)	mbar	8,10	8,00	7,25	7,10	6,90	9,20	8,50	8,30	7,50	9,20
	Inlet pressure	mbar	20									
Prop. Gas G31	Injector	quantity	-	5	6	8	10	8	8	10	12	10
	Injector size	mm	-	1,15	1,15	1,15	1,15	1,40	1,45	1,45	1,50	1,95
		marking	-	115	115	115	115	140	145	145	150	195
	Burner pressure (1)	mbar	-	35,80	35,80	36,20	35,90	30,10	35,60	35,40	34,40	30,70
	Inlet pressure	mbar	37									

Special poland

LCSA-3		Model	12	20	30	35	45	50	60	75	100	120
G27	Injector	quantity	-	5	6	8	10	8	-	10	-	-
	Injector size	mm	-	2,40	2,40	2,40	2,40	2,60	-	3,00	-	-
		marking	-	240	240	240	240	260	-	300	-	-
	Burner pressure (1)	mbar	-	8,30	8,20	8,35	8,25	11,40	-	9,25	-	-
	Inlet pressure	mbar	20									
G2,350	Injector	quantity	-	5	6	8	10	8	-	10	-	-
	Injector size	mm	-	2,60	2,60	2,50	2,60	3,40	-	3,90	-	-
		marking	-	260	260	250	260	340	-	390	-	-
	Burner pressure (1)	mbar	-	8,25	8,45	9,55	8,40	6,00	-	5,25	-	-
	Inlet pressure	mbar	13									

Austria, Germany, Hungary, Russian Federation, Ukraine

LCSA-3		Model	12	20	30	35	45	50	60	75	100	120
Nat. Gas G20	Injector	quantity	5**	5	6	8	10	8	8	10	12	10
	Injector size	mm	1,50	2,10	2,10	2,20	2,20	2,40	2,70	2,70	2,90	3,40
		marking	150	210	210	220	220	240	270	270	290	340
	Burner pressure (1)	mbar	8,10	8,00	7,25	7,10	6,90	9,20	8,50	8,30	7,50	9,20
	Inlet pressure	mbar	20(*)									
Prop. Gas G31	Injector	quantity	-	5	6	8	10	8	8	10	12	10
	Injector size	mm	-	1,15	1,15	1,15	1,15	1,40	1,45	1,45	1,50	1,95
		marking	-	115	115	115	115	140	145	145	150	195
	Burner pressure (1)	mbar	-	35,80	35,80	36,20	35,90	30,10	35,60	35,40	34,40	30,70
	Inlet pressure	mbar	50									

(*): Inlet pressure for Hungary = 25mbar

(**): no nat gas for Germany

Bulgaria, Denmark, Finland, Norway, Sweden

LCSA-3		Model	12	20	30	35	45	50	60	75	100	120
Nat. Gas G20	Injector	quantity	5	5	6	8	10	8	8	10	12	10
	Injector size	mm	1,50	2,10	2,10	2,20	2,20	2,40	2,70	2,70	2,90	3,40
		marking	150	210	210	220	220	240	270	270	290	340
	Burner pressure (1)	mbar	8,10	8,00	7,25	7,10	6,90	9,20	8,50	8,30	7,50	9,20
	Inlet pressure	mbar	20									
Prop. Gas G31	Injector	quantity	-	5	6	8	10	8	8	10	12	10
	Injector size	mm	-	1,15	1,15	1,15	1,15	1,40	1,45	1,45	1,50	1,95
		marking	-	115	115	115	115	140	145	145	150	195
	Burner pressure (1)	mbar	-	28,06	28,06	28,37	28,14	23,59	27,90	27,75	26,96	24,10
	Inlet pressure	mbar	30									

Romania

LCSA-3		Model	12	20	30	35	45	50	60	75	100	120
Nat. Gas G20	Injector	quantity	5	5	6	8	10	8	8	10	12	10
	Injector size	mm	1,50	2,10	2,10	2,20	2,20	2,40	2,70	2,70	2,90	3,40
		marking	150	210	210	220	220	240	270	270	290	340
	Burner pressure (1)	mbar	8,10	8,00	7,25	7,10	6,90	9,20	8,50	8,30	7,50	9,20
	Inlet pressure	mbar	20									
Prop. Gas G31	Injector	quantity	-	5	6	8	10	8	8	10	12	10
	Injector size	mm	-	1,20	1,20	1,20	1,20	1,45	1,50	1,50	1,60	1,95
		marking	-	120	120	120	120	145	150	150	160	195
	Burner pressure (1)	mbar	-	28,60	28,80	29,20	28,80	28,10	28,50	28,40	27,70	26,40
	Inlet pressure	mbar	30									

(1) : with open service door

2.2 Dimensions

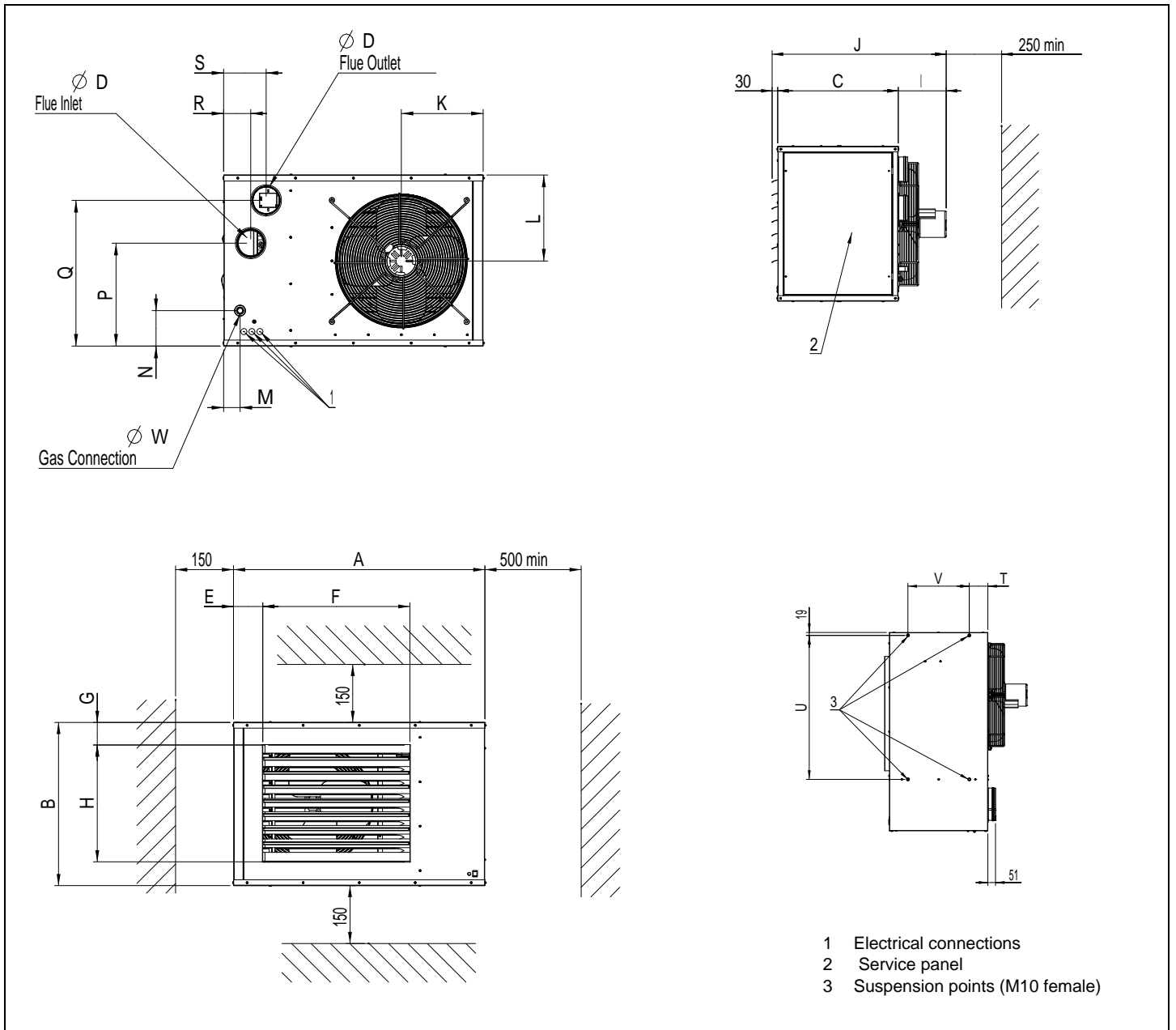

LCSA	A	B	C	D	E	F	G	H	I	J	K	L	M	N	P	Q	R	S	T	U	V	W
12-3	965	567	652	80	71	531	130	305	100	782	334	280	87	106	345	444	122	221	123	611	406	1/2"G
20-3	965	567	652	100	71	531	130	305	103	785	334	280	87	106	345	444	122	221	123	611	406	1/2"G
30-3	965	567	652	100	74	531	94	370	139	821	334	280	87	106	345	444	122	221	123	611	406	1/2"G
35-3	965	845	652	130	74	531	154	517	142	824	331	420	82	175	508	720	134	211	123	611	406	3/4"G
45-3	965	845	652	130	74	531	117	605	142	824	331	420	82	175	508	720	134	211	123	611	406	3/4"G
50-3	1298	845	652	130	151	759	154	517	156	838	409	425	82	175	508	720	135	212	123	942	406	3/4"G
60-3	1298	845	652	130	151	759	154	517	142	824	409	425	82	175	508	720	135	212	123	942	406	3/4"G
75-3	1298	845	652	130	151	759	117	605	142	824	409	425	82	175	508	720	135	212	123	942	406	3/4"G
100-3	1298	954	807	130	151	759	73	808	185	1022	479	477	82	180	608	833	212	212	123	942	550	3/4"G
120-3	1750	980	846	130	67	1100	164	602	181	1057	348	490	90	175	595	795	160	256	20	1365	770	3/4"G
145-3	1750	1150	846	130	67	1100	173	692	181	1057	348	570	90	177	736	936	160	256	20	1365	770	3/4"G

3.1 Related documents

It is important that all gas appliances are installed in accordance with the rules in force and by appropriately qualified persons. Failure to install appliances correctly could lead to prosecution. It is in your own interest and that of safety to ensure compliance with the law.

3.2 Heater location

The location chosen for the air heater must permit the provision of a satisfactory flue system venting to outdoor atmosphere and adequately ventilated to provide for combustion air. The location must also provide sufficient space to allow the heater to be serviced.

Table 3
Minimum installation clearances (mm)

LCSA-3	
Top	150
Flue connector	150
Access panel	800
Non access side	150
Bottom	150
Rear*	450

* Measure rear clearance from the back of the motor

Table 4
Recommended mounting heights to underside (m)(*)

LCSA-3	12->20	30->50	60->145
Mounting height	3	4	5

* Height from floor to bottom surface of heater. These are recommendations only. Positioning of heaters depends on application.

Air heaters should, where ever possible always be installed to blow toward or along external wall surfaces. Where two or more air heaters are installed in the same room, a general scheme to ensure continuous air circulation should be maintained for best results.

Suspended heaters are most effective when located as close to the occupancy zone as possible, this fact should be born in mind when determining the mounting heights to be used. Care should be exercised to avoid directing warm air directly onto the occupants. Partitions, columns, counters, storage racking, etc. should be taken into account when choosing the location so that an unobstructed path for the air circulation can be maintained.

Where air heaters are located in the centre of the space to be heated, the air should be discharged toward outside walls. In large areas, they should be located to discharge air along outside walls with additional heaters provided to blow air into the centre of the area.

In places where infiltration of cold is excessive, such as entrance doors it is desirable to locate a heater so that warm air is discharged directly toward the source of cold air from a distance of 4,5 - 6,0m



Air heaters should not be installed in corrosive atmospheres, i.e. near plating or degreasing plants or in areas where there is a fire risk.



Do not locate the air heater where it may be exposed to water spray, rain, etc.

3.3 Combustion air supply & flue system

The air heater may be installed as a balanced flue (Type C) heater requiring both a combustion air inlet duct and a flue pipe or as a power vented (Type B) heater, which requires only a flue pipe exhausting to outdoors. All products of combustion must be flued to outdoor atmosphere.

Figure 2a : Combustion air and flue pipe sockets

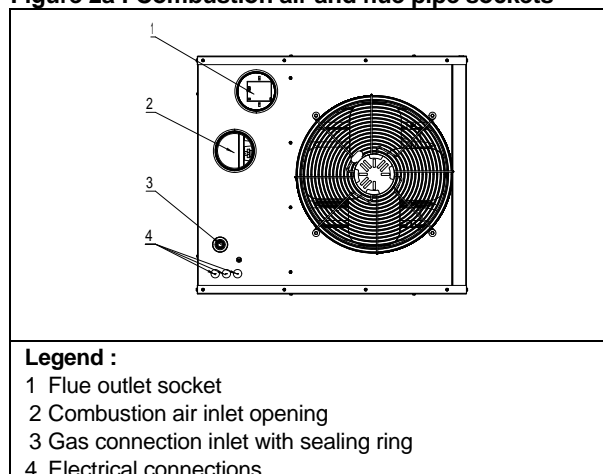

Each heater installed as a type B appliance must be fitted with an individual flue pipe and the combustion air inlet opening must be provided with a protection grill (ask your distributor for the appropriate protection grill (IP20) (dia130 = PN 02 25094). Each heater installed as a type C appliance must be fitted with an individual combustion air/flue pipe system. Only systems specified by the air heater manufacturer may be used.

Common flue and combustion air systems must not be used

IMPORTANT: The flue must be installed in accordance with national and local regulations. Failure to provide proper flueing could result in death, serious injury and/or property damage. The air heater must be installed with a flue to the outside of the building. Safe operation of any power vented gas apparatus requires a properly operating flue system, correct provision for combustion air, and regular maintenance and inspection.

3.3.1 Flues for power vented installations (Type B appliances)

If the air heater is to be installed as a type B appliance, air for combustion will be taken from within the space where the heater is installed. Ensure that an adequate air supply for combustion and ventilation is provided within the building in accordance with the regulations & rules in force.

Table 5 shows flue pipe sizes and maximum pipe lengths. The minimum flue length is 0.5 metres.

Table 5 Flue pipe diameters & maximum lengths

LCSA-3		12	20, 30	35,45,50,60,75 100,120,145
Heater socket & pipe dia	mm	80	100	130
Maximum straight length	m	9		
Equivalent length of 45° elbow	m	0.75		
Equivalent length of 90° elbow	m	1.5		

Single wall flue pipes are required. All joints must be sealed to prevent products of combustion from leaking into the building. An approved flue terminal is required.

If the flue passes through a combustible element of the building it must be enclosed by a sleeve of non-combustible material and separated from the sleeve by at least a 25 mm air break. The temperature of any combustible material near to the flue must not exceed 65°C when the heater is in operation. The flue must be at least 50 mm away from any combustible material.

Single wall flue pipe exposed to cold air or run through unheated areas must be insulated. Where condensation is unavoidable, provision must be made for the condensation to flow freely to a point to which it can be released, i.e. a drain or gully. The condensation drain from the flue must be constructed from non-corrodible material not less than 20 mm diameter. Copper or copper based alloys must not be used for condensation drains.

3.3.2 Combustion air inlet pipe & flue pipe for balanced flue installation (Type C appliances)

Balanced flue air heaters are designed to be fitted with a combustion air inlet pipe that obtains outdoor air and a flue pipe that exhausts flue products to outdoors.

Air heaters if fitted with a power venter permitting either a vertical or horizontal combustion air inlet/flue pipe system. **The heaters must be installed with a concentric vertical or horizontal flue/combustion air inlet. The heaters are only approved for use when installed with the appropriate approved concentric vent terminal.** See table 6.

Both the flue and combustion air pipes must be sealed. Use gasket sealed seamless aluminium pipe or equivalent.

The flue pipe must include a re-sealable test port to allow good average sampling of the flue gas mixture for testing, the port must be at least 450 mm away from the air heater flue connection socket.

Follow any flue pipe manufacturers' installation instructions for making joints, including connections to the air heater, for passing through a building element and for support requirements. If more than one air heater is being installed in the same place each heater must have a separate flue system.

Where condensation is unavoidable, provision must be made for the condensation to flow freely to a point to which it can be released, i.e. a drain or gully. The condensation drain from the flue must be constructed from non-corrodible material not less than 20 mm diameter. Copper or copper based alloys must not be used for condensation drains.

Figure 2b : Combustion air and flue pipe sockets, Type C

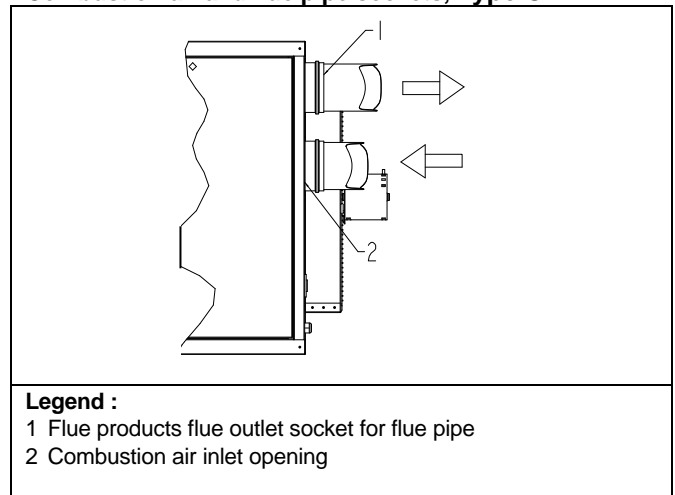

Table 6 Combustion air inlet & flue pipe requirements

LCSA-3		12	20, 30	35 -> 145	
Heater socket & pipe dia	mm	Flue pipe	80	100	130
		Inlet pipe	80	100	130
Max. straight length	m	Flue pipe	9		
		Inlet pipe	9		
Equivalent length of 45° elbow	m	Flue pipe	0,75		
		Inlet pipe	0,75		
Equivalent length of 90° elbow	m	Flue pipe	1,5		
		Inlet pipe	1,5		

Concentric vertical vent or wall terminal : Mugro/Burfix dia 130
 Concentric horizontal vent or roof terminal : Mugro/Burfix dia 130

3.4 Air supply

It is important to ensure that there is an adequate air supply at all times for both combustion and heating requirements. Modern constructions involve the greater use of insulation, improved vapour barriers, and weather proofing. This practice means that buildings are sealed much tighter than in the past.

The combustion air supply for a power vented gas fired air heater (Type B installation) can be affected by lack of air supply. Natural infiltration may not be adequate. Use of extract fans aggravates this situation. It is important to ensure that there is an adequate air supply at all times. Reliance on doors and windows is not allowed. Always ensure that an adequate inlet for fresh air for combustion is provided sized to suit the total installation of any combustion apparatus.

Fit an access guard to the combustion air inlet on the back of the heater and take appropriate action to ensure that it remains unblocked. See figure 2c.



WARNING: This model air heater is installed as a type B application and is designed to take air for combustion from the space in which it is installed. Do not restrict the combustion air intake.

Figure 2c :
Combustion air and flue pipe sockets, Type B

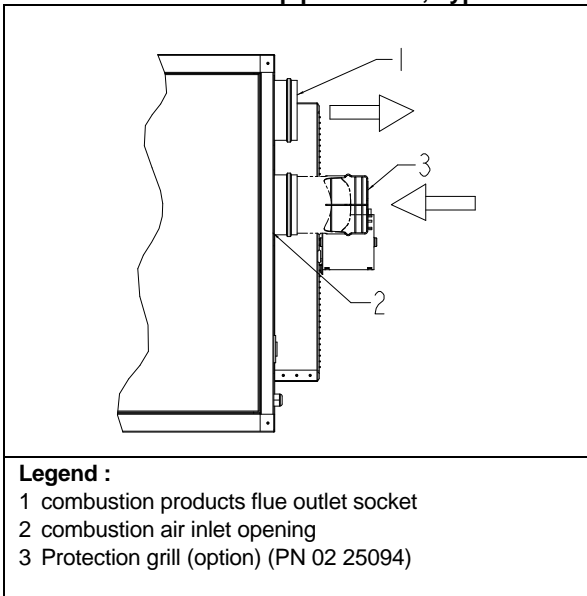

3.5 Air distribution

Follow recommended practice for building air distribution.

The following notes are of particular importance:

"Where free blowing air heaters are installed it must be taken into account that heated air is buoyant when it leaves the appliance, therefore, air patterns within the space being heated will modify the air throw pattern achieved.

In building having low heat loss where single heaters are required to cover a large floor area and in buildings with high ceiling heights, air re-circulation fans e.g. Maximizers may be fitted to ensure even heat distribution and minimize stratification. Care should be taken to avoid impeding air flow with storage racking, partitions, etc."

3.6 Electrical supply

Wiring external to the air heater must be carried out in accordance with the rules of force and by appropriately qualified persons.

A constant 230 Volt 50 Hertz single phase fused electricity supply with neutral link is required. All heaters and controls must be earthed. A lockable isolator with contact separation of at least 3.0 mm on all poles should be installed adjacent to the appliance and within reach of any person working on the heater.

When a number of heaters are to be connected as part of a single installation each heater must be provided with a separate isolator.

The electrical connection to the air heater is at the back of the appliance. The final connection must be made in the terminals provided in the control compartment. Follow the wiring diagram provided with the air heater.

Electrical supply cable conductor size should be 1.5 mm. Fit the cord grip supplied with the heater. The length of conductors between the cord grip and the terminals must be such that in the event that the cable becomes taut the line conductors do so before the earth conductor.

3.7 Gas supply

LCSA-3 air heaters are designed to operate on either natural gas (G20) or propane gas (G31). Refer to the specifications in section 2 of this document and to the data plate for details of supply pressures.

The gas meter and gas service must be checked by the supply undertaking to ensure that they are adequate to deal with the total load of all gas fired apparatus installed.

4.1 Unpacking and preparation

Prior to dispatch, the air heater was operated and tested at the factory. If the heater has incurred any damage in shipment, file a report claim within 2 working days from receipt.

Check the shipping label and data plate to ensure the specification of gas and electrical supplies are compatible. Read this document and become familiar with the installation requirements and the appliance before commencing installation.

4.2 Suspending the air heater

Before installing the appliance, check to ensure that the supporting structure is adequate to carry the weight of the appliance and its ancillaries i.e. flue system.

Table 7 Approximate Net weights (kg)

LCSA-3	12 20	30	35	45	50 60	75	100	120	145
Weight	59	64	94	99	114	126	184	242	279

When the heater is lifted for suspension, support the bottom of the heater with plywood or other appropriately placed material. If the bottom is not supported, damage could occur.

The heater is supplied with four point suspension. All points must be used. Two threaded nut retainers are provided on each side of the top of the heater. See dimensions in section 2.2 and figure 3.

Figure 3 Suspension detail

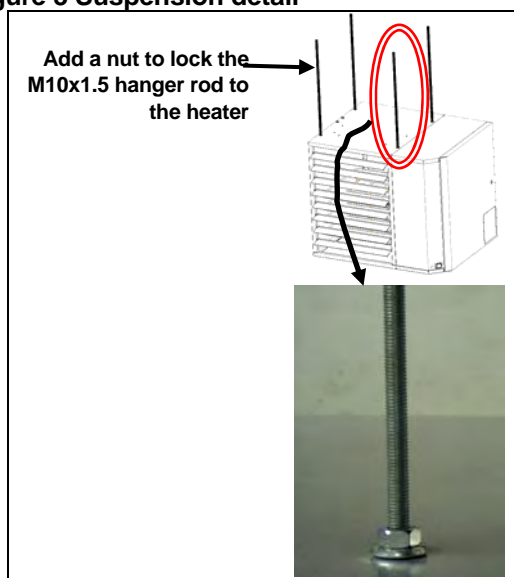

Be sure that the threaded hanger rods are locked to the heater as illustrated. Recommended maximum hanger rod length is 1.8m.

IMPORTANT:

Suspend the heater from the threaded nut retainers. Do not suspend from the heater cabinet panels.

Do not place or add additional weight to the suspended air heater. See hazard levels, page 2.

The heater must be installed in a level plane to ensure proper operation.

4.3 Fitting the Combustion air inlet/Flue system

Flue pipe runs may be horizontal or vertical and terminate either through the wall or roof. See table 5 for maximum pipe length for an appliance installed as type B or table 6 for maximum lengths and approved supplied concentric terminals for a heater installed as a type C appliance.

All pipe runs must be independently supported so that the heater does not carry any of the weight of the flue system.

4.3.1 Fitting the flue pipe

The flue pipe socket is located on the back of the air heater.

Flue pipes must be sealed. Use seamless, aluminium pipe or equivalent. Follow pipe manufacturer's instructions (see figures 4 & 5).

Table 8 Flue pipe socket size (dia mm)

LCSA-3	12	20,30	35 -> 145
Socket	80	100	130

4.3.2 Installing a guard on the combustion air inlet pipe for power vent (Type B installations)

The combustion air inlet socket is located at the back of the heater. When installed as a type B appliance, protect the inlet by fitting an access guard on the socket. **Do not block this socket as it supplies combustion air for the burner (see figure 4).**

4.3.3 Fitting the combustion air inlet pipe for balanced flue (Type C installations)

The combustion air pipe attaches directly to the inlet socket at the back of the heater. Air inlet pipes must be sealed. Use seamless aluminium or equivalent. Follow the pipe manufacturer's installation instructions. See typical installations in figure 5.

Table 9 Air inlet socket size (dia mm)

LCSA-3	12	20,30	35 -> 145
Socket	80	100	130

Figure 4

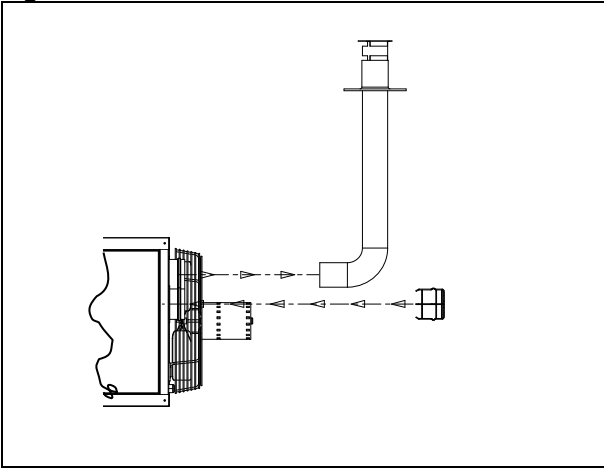

4.4 Gas connection

Connection to a gas network may only be carried out by appropriately qualified persons. The gas installation must comply with the rules in force using materials appropriate for gas installation.

To facilitate servicing, the air heater must be fitted with an approved gas service tap and union fitting or union tap adjacent to the appliance.

The inlet gas supply line must be installed so as to permit the access door to be opened and to allow removal of the slide out burner assembly.

Air heaters suspended by flexible suspension materials or drop rods must be connected to the gas supply using an approved flexible connector. Sufficient slack must be provided in the connection to allow for movement of the appliance. Use a flexible connector of suitable size to reduce the pressure drop and the possibility of gas flow noise.



Do not use the appliance gas supply to balance or support any part of the appliance.

Figure 6

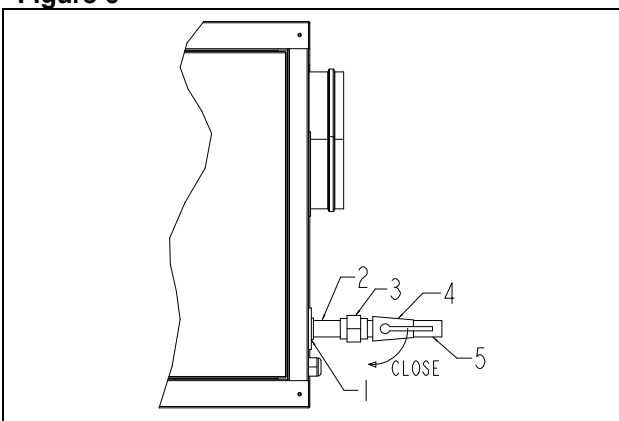

Legend :

- 1 Gas tube inlet sealing ring
- 2 Inlet gas pipe
- 3 Union fitting
- 4 Gas service tap
- 5 Gas pipe

Figure 5

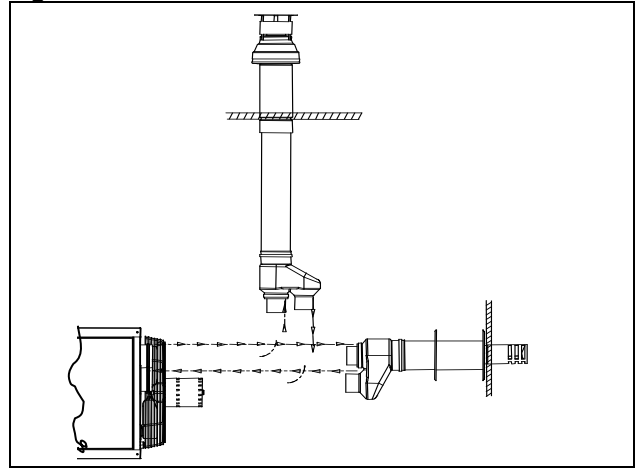

4.5 Electrical connections

The electrical installation may only be carried out by appropriately qualified persons observing the rules in force.

All electrical connections should be made in the heater control compartment (refer to figure 9). Screw type terminals are provided. Connections should be in accordance with the terminal markings and the wiring diagram affixed to the air heater or included with this document.



THIS APPLIANCE MUST BE EARTHED!

ATTENTION : Failure in electrical wiring can bring real damage to components of this appliance. Please follow very carefully the wiring diagram supplied with this air heater.

The minimum external controls required for the air heater are a room thermostat. **It is essential the main input line and neutral to terminals L and N remains live at all times even when the appliance is switched off this is to ensure correct operation of the unit.**

An indicator light and burner reset button are fitted inside the appliance. To add a remote reset button, make connections to the terminals in the electric box as indicated on the wiring diagram.

IMPORTANT:

If the reset button requires activating for any reason the cause should be identified before resetting. After resetting stay with the appliance for long enough to ensure that lock-out does not reoccur (suggest 5 minutes).

Fix all electric cables and installer's wiring to the control panel and ensure they do not touch the combustion collector box.

4.6 Room thermostat location

Do not attempt to control more than 1 air heater from a room thermostat or control panel unless a properly wired relay is fitted. Follow instructions supplied with such panels.

The location of the room thermostat is important. It should not be fitted on an outside wall. Avoid location in draughty areas or where it may be influenced by heat

sources e.g. the sun, process plant, etc. The thermostat or temperature sensor should be mounted on a vibration free surface and mounted about 1,5 meters above floor level. Follow the thermostat manufacturers fitting instructions. The thermostat must be suitable for switching 230 volts.

5 AIR DISTRIBUTION

LCSA-3 air heaters are fitted with adjustable horizontal louvers over the range 0 - 45 degrees from the horizontal so as to be able to direct the airflow downwards.

DO NOT ADJUST THE LOUVRES BEYOND THEIR STOPS.

6 COMMISSIONING & TESTING

The commissioning and testing may only be carried out by appropriately qualified persons. This section should be read and fully understood before commencing commissioning and testing.

6.1 Electrical check

After completion of the installation and before switching on the electrical supply to the appliance, a preliminary check must be carried out by a qualified electrician. The following must be checked:

- * Ensure that all cables & installer's wiring are fixed to the gas pipe & that they do not touch the combustion collector box
- * Check that all wiring is connected in accordance with the appliance circuit diagram;
- * Ascertain that the correct fuse value and cable size has been provided;
- * Check to ensure that the appliance is earthed by conducting an earth continuity test. Connect a test meter, one lead to the appliance earth terminal and the other to the mains incoming earth point at the electrical isolator. A resistance reading of 1,0 ohm or less must be indicated. If a higher reading is obtained, check all cable connections to ensure adequate security and cleanliness. If problem still exists, it may be necessary to consult the electricity supply undertaking;
- * Carry out a polarity test. Connect one lead of a suitable AC voltmeter to earth and connect the

other lead to the live supply terminal (L) at the air heater. Switch ON the power to the air heater and check for correct voltage.

The same result should be obtained by connecting the test leads between live and neutral.

Connect the voltmeter test leads to N and E. A reading of 0V should be obtained. If these tests do not conform to the above, there is a fault which must be rectified before proceeding further with the commissioning;

- * Check that a suitable thermostat or control panel has been fitted;
- * Ensure that an electrical isolator with two pole separation with a minimum air break between poles of 3,0 mm has been fitted adjacent to the air heater.

6.2 Gas connection

Only persons formally qualified to work on gas fired apparatus may carry out commissioning and testing.

The whole of the gas service installation including the meter must be inspected, tested for soundness and purged in accordance with appropriate requirements by a qualified person.



Never use a flame for checking gas soundness.

6.3 Suspension and support

Check to ensure that the air heater is adequately suspended or supported and that no other parts have been fitted that are not independently supported and secured. For safe and correct operation, check the heater is level in both planes.

6.4 Lighting the air heater

LCSA-3 air heaters are all fitted with automatic spark ignition systems. When adequate airflow for combustion is proven by an air proving control and a pre-purge period has elapsed, the integral ignitor and multi-functional gas control operate. The ignition spark ignites the gas creating the burner flame which is detected by a flame rod sensor. If a burner flame is not detected, the ignition controller proceeds to lock-out and requires manually resetting. Lock-out is indicated by the red warning light on the air heater.

Note : If the first reset is not successful, wait 15 seconds before attempting reset.

6.4.1 To turn the air heater "ON"

The following checks should be carried out before attempting to light the air heater.

- * Ensure that the gas supply to the air heater is turned ON;
- * Ensure that the electrical supply to the air heater is switched **ON**;
- * If fitted ensure that a time switch is set to an ON period
- * Set room thermostat to call for heat. e.g. to above room ambient temperature. The burner will now light.

The burners can be seen through the viewing port.

- * Adjust the room thermostat to the required operating comfort temperature. The air heater will now start automatically when heat is called for by the room thermostat.

Note : If the air heater will not start on initial start-up, the ignition controller may be in lock-out position and require resetting. This may occur especially if the appliance has been on stand-by for a prolonged period.

6.4.2 To turn the air heater "OFF" for short periods

Adjust the room thermostat to its lowest setting or 'OFF'. The fan will continue to run to cool the heater and then switch OFF automatically.

6.4.3 To turn the air heater "OFF" for long periods

Adjust the room thermostat to OFF or its lowest setting. When the fan has stopped, turn OFF the gas supply and then switch OFF the electricity supply to the air heater.

6.5 Air heater gas pipe work

The soundness of the air heater pipe work has been checked prior to leaving the factory. However during installation, connections may have been loosened. Check the soundness of the appliance pipe work using a soapy solution. If any leaks are found they must be rectified immediately.



Never use a flame for checking gas soundness.

6.6 Adjustments

6.6.1 Burner gas pressure adjustment

The gas pressure is set for the required heat input before the appliance leaves the factory. Provided the gas supply to the air heater is in accordance with the supply pressure described on the appliance data plate the operating pressure will not require adjustment. To check the pressure, the following procedure should be carried out:

- * Ascertain from section 1 of this document and the appliance data plate the correct operating gas pressure for the air heater;
- * Turn the room thermostat control to its lowest setting;
- * Remove the screw from the burner pressure test point of the multi-functional control valve. Connect a manometer to the test point(see figure 7);
- * Adjust the room thermostat to call for heat e.g. above room ambient temperature;
- * Observe the burner gas pressure on the manometer and compare to the required pressure;
- * If necessary, adjust the burner gas pressure (only for natural gas). Remove the cover screw. Turn the regulator screw anti-clockwise to decrease pressure or clockwise to increase pressure (see figure 7);
- * Set room thermostat to lowest setting to turn the burners OFF. Replace the test point screw (if removed) and with the main burner alight, test for gas soundness using a soapy solution. Reset temperature control/room thermostat to comfort operating level.

Figure 7 : Honeywell gas valve

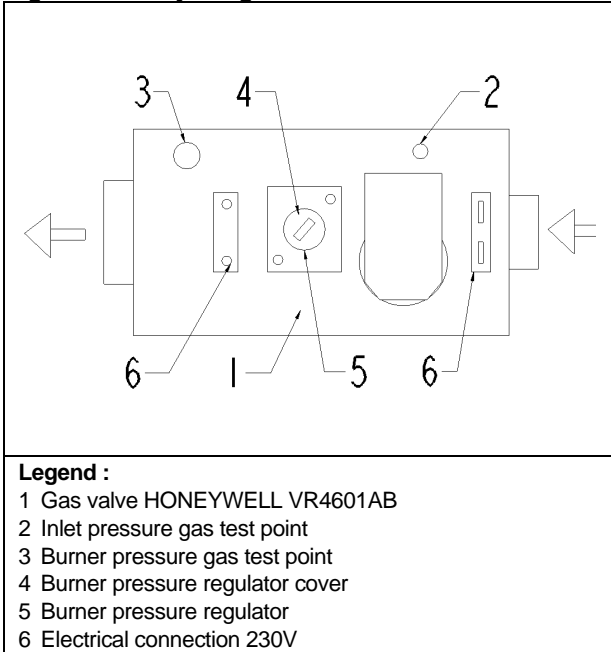

Turn room thermostat to its lowest setting. The main burners should extinguish while the fan continues to run to cool the air heater. The fan delay relay will normally be de-energized and stop the fan motor in approximately 45 seconds.

Table 10 Combustion air pressure control settings

LCSA-3	Normal equilibrium warm (Pascal)	Set point 'off' (Pascal)
12-3	>131	119
20-3	>163	135
30-3	>170	130
35-3	>200	155
45-3	>183	155
50-3	>183	155
60-3	>240	175
75-3	>290	185
100-3	>250	210
120-3	>250	238
145-3	>250	238

at 2x1m pipe with terminal

6.7 Air distribution system

Adjust the air outlet discharge louvres to provide a satisfactory spread of the warm air. Direct the air towards the floor avoiding blowing directly on people who may be in the vicinity of the appliance.



If louvre adjustment is carried out whilst the appliance is hot wear gloves to avoid being burnt.

6.8 Air heater controls and operation

Check air heater operation after all adjustments have been carried out. Set the temperature control above ambient temperature.

LCSA-3 air heaters are fitted with a pressure sensitive, combustion air safety control that monitors the combustion airflow.

The control operates with the settings given in table 10 (settings are for sea level installations)

When the combustion air safety control closes, verifying airflow, the gas control valve will open and the burner will light. When insufficient airflow, the burner will extinguish until the airflow returns to the acceptable level.

Wait approximately 30 seconds after the burner has lit, the time delay relay will activate the thermal fan control which will energize the fan motor. Continue to operate the air heater for several minutes to ensure correct operation.

6.9 Handing over

Upon satisfactory completion of commissioning and testing, hand the instructions to the user or their representative.

Advise the appropriate person how to safely use and operate the air heater and describe the use of appropriate external controls. Ensure that the person understands how to start the heater and how to turn it OFF.

Suggest that the instructions are placed close to the air heater for future reference. In the absence of an appropriate location fix them to the gas service meter. Ensure they are not placed where they may restrict the airflow from the heater or where they may catch fire from a hot surface.

Advise the person who is resuming responsibility that for continued safe operation the air heater should be serviced at least once a year.

IMPORTANT:

Only appropriately qualified persons may carry out servicing and fault finding on this gas fired equipment. Before commencing service ensure that both the gas and the electricity are turned and switched "OFF" and that the air heater has cooled down. Inadvertent substitution or replacement of components similar to those specified or replacement in a manner contrary to the method herein described could constitute a hazard and lead to prosecution.



When cleaning air heaters, wearing of eye protection and a dust face mask is recommended.

LCSA-3 air heaters will operate with a minimum of maintenance. To ensure long life and satisfactory and safe performance, an air heater that is operated under normal conditions should be inspected and cleaned at the start of each heating season. If the air heater is operated in an area where unusual amounts of dust, etc are present in the air, more frequent servicing is recommended.

When any service is completed, be sure that components are reassembled correctly to ensure that no unsafe condition exists.

Upon completion of the service carry out the commissioning instructions outlined in section 6 of this document.



WARNING: Excessive dirt build-up on the inside of the burner ports could cause unburnt gas to spill out of the back of the burner tube causing a fire or explosion. To prevent this occurring, clean all of the burner ports at least annually.

Service procedure

The following procedures should be carried out at least annually:

- Remove the burner assembly as in section 8.1. Clean thoroughly, (cleaning the burners requires an emery cloth, wire brush and a cleaning cloth - stubborn deposits on burners are best cleaned using "acetone" as a solvent).
 - * Check the condition of the ignitor and clean to remove all deposits. Check the spark gap (3,0 mm).
 - * Check the sensor - clean as necessary.
 - * Remove any soot deposits from the burner with a wire brush. Clean the ports with a degreaser or acetone. A vacuum cleaner or compressed air may assist in this cleaning operation. Wipe the
- inside of the burner tube clean (cleaning thoroughly with a degreaser as recommended will retard future build-up of dirt). Inspect the burner for any damage or deterioration. If the burner is damaged or corroded, replace it.
- The heat exchanger should remain clean unless a problem has developed due to poor combustion. Examine the heat exchanger tubes internally and externally for any sign of deterioration. The outside of the tubular heat exchanger can be cleaned from the front of the heater with an air jet and/or a flexible brush. Remove any dust and grease deposits. The inner surfaces of the heat exchanger can be reached for cleaning with the burner and combustion air fan (venter) assemblies removed. Clean with a flue brush or a heavy wire to which wire wool has been attached. Brush inside each heat exchanger tube until all foreign material has been removed. The use of a flashlight is necessary to carry out this operation.
- Clean the axial fan blades, fan guard, and fan motor to remove all external dirt . Check the security of the fan on the motor.

Note: Fan motors are lubricated for life and do not require lubricating.

- Remove any dirt and/or grease that may have accumulated on the venter fan motor and its housing. **NOTE:** The combustion air fan motors are lubricated for life and do not require oiling or greasing.
- The gas multi-functional control valve requires no field maintenance except cleaning of its exterior and checking the condition of the wire connections. Instructions for testing pressure are given in section 6.6.
- Check the flue/combustion air system for soundness. Reseal/replace any parts that are not sound.
- Check all wiring connections. Check wiring for any signs of damage. Replace any suspect wiring with an equivalent specification.
- Check operation of thermal fan control and control relay.
- When service is complete carry out full commissioning procedure as per section 6 of this document.

8 Removal & replacement of parts

LCSA-3 air heaters must only be fitted with authorized replacement parts. These heaters must use certificated spare parts to comply with legislation.

8.1 Main burner removal

Instructions for burner removal (see figure 8):

1. Turn OFF the gas supply to the air heater.
2. Switch OFF the electricity supply to the air heater.
3. Open the access door.
4. Disconnect the union in the gas supply outside of the appliance.
5. Remove gas supply pipe from multi-functional gas control valve.
6. At the burner rack assembly, remove the nuts that secure the burner manifold to the burner rack. Lift the burner rack/manifold assembly upward and pull the assembly out of the air heater.

Instructions for re-assembly:

1. Reverse the procedure for removal making sure that all parts are installed correctly. Check that all components are secure.
2. When lighting, always follow the lighting instructions on the air heater.

Remember!

After any service work has been carried out, the air heater must be fully commissioned. See section 6 of this document

Figure 8 (for clarity, the heater cabinet & other parts are not illustrated)

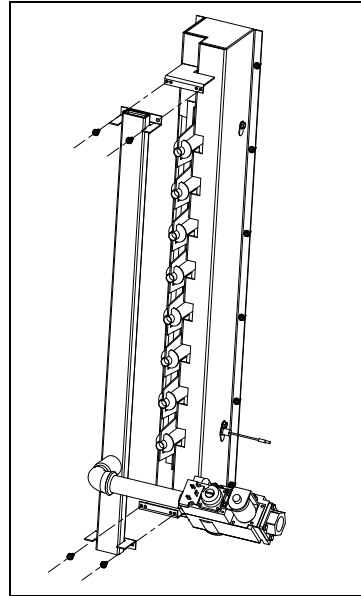
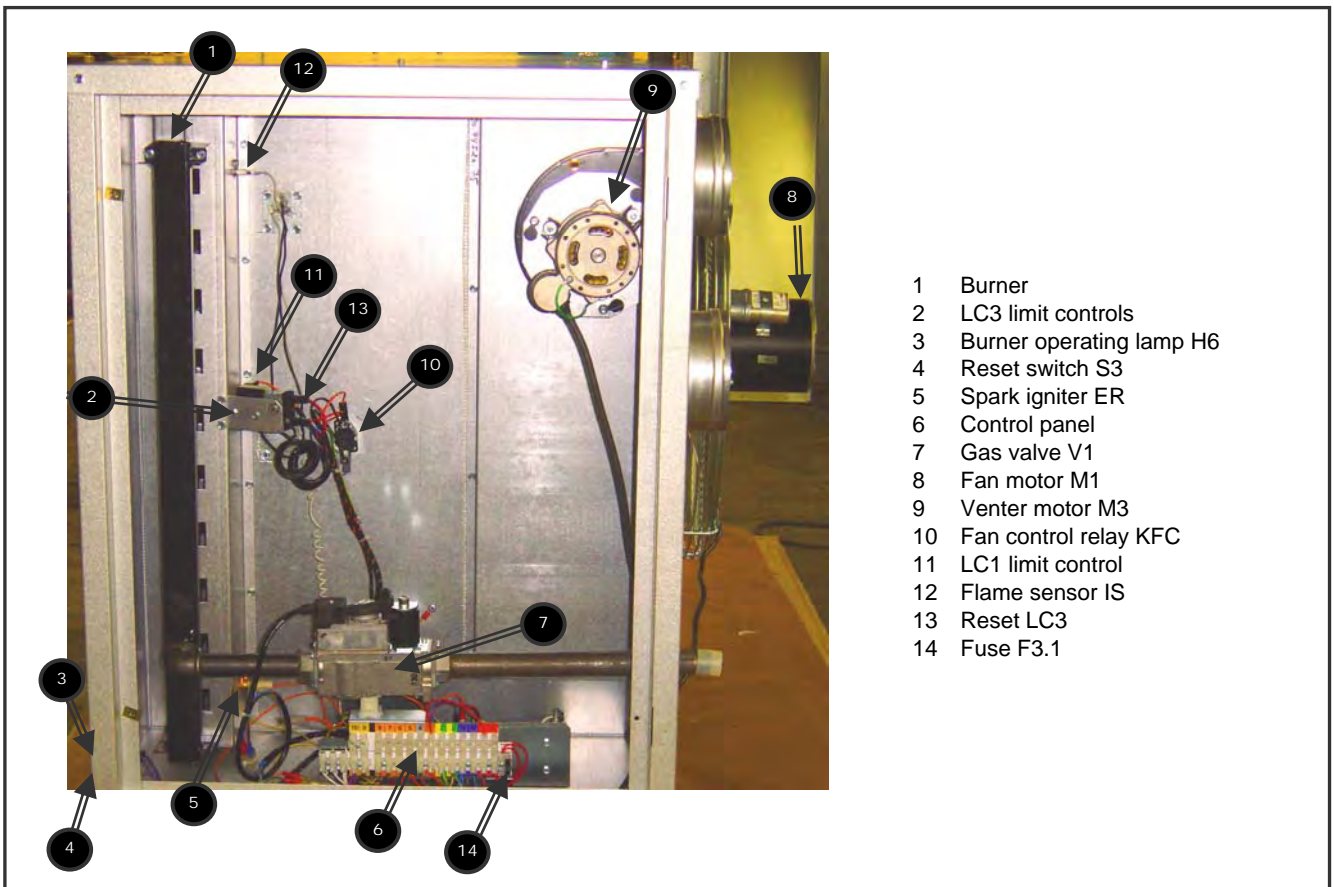

Figure 9 View of the Control Compartment



8.2 Burner injectors

1. Carry out steps 1 to 6 of section 8.1.
2. Unscrew the main burner injectors.
3. Re-fit new injectors.
4. Re-assemble in reverse order.

8.3 Ignition system

To access the ignition system, follow steps 1 to 3 in section 8.1.

Ignitor- refer to figure 9 and locate the ignitor (on the side of the burner rack). Disconnect the wire, remove the screw and the ignitor. Clean with an emery cloth.

Note: Spark gap must be maintained to 3.0 mm (see figure 10a)

Re-fit the ignitor as per figure 10b.



Due to high voltage on the spark wire and electrode, do not touch when energized. See hazard levels.

Flame sensor - Refer to figure 9 and locate the flame sensor. Disconnect the wire, remove the screw and the flame sensor. Clean with an emery cloth.

Ignition controller - The enclosed integrated circuit monitors the operation of the burner including ignition. Do not attempt to dismantle the ignition controller. Each heating season ignition cables should be checked for insulation deterioration and good connections.

Proper operation of the direct spark ignition system requires a minimum flame current of 1,0 μ A when measured with a micro-ammeter.

Fig. 10a - Ignitor assembly

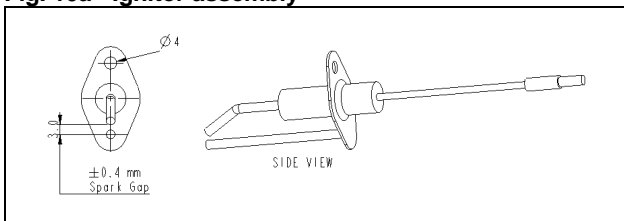
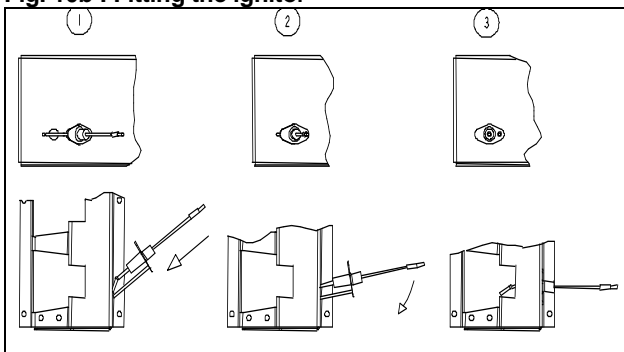

Fig. 10b : Fitting the ignitor



For further information and checkout procedure of the direct spark ignition system, refer to the manufacturers control operating instructions a copy of which is supplied with the air heater.

8.4 Multi-functional gas control valve

1. Ensure gas supply to the air heater is turned OFF.
2. After the air circulation fan has stopped, switch OFF the electricity supply to the air heater.
3. Mark for future identification and disconnect the wires connected to the valve.
4. Disconnect the gas service union between the control valve and the gas service tap. Remove the gas control valve.
5. Re-fit a replacement valve making all of the required connections.
6. Carry out complete commissioning procedure prior to placing the appliance back into service as outlined in section 6.0



The gas control operating valve is the prime safety shut-off.

All gas supply lines must be free of dirt, scale, etc. before connecting to the air heater thus ensuring positive closure of the control valve.

8.5 Thermal overheat (limit) controls

If it is determined that the thermal overheat control needs replacing, use only authorized replacements that are designed for this appliance.

To gain access to the control, open the controls compartment access door. Refer to figure 9 for control locations. The control near the top of the air heater is a disc type control. Both controls are capillary types with a capillary tube that extends into the heat exchanger area. To remove the controls, disconnect the wires leading to them, remove the fixing screws and lift clear of the inner casing panel.

Note: The capillary control is fitted to a bracket. With the bracket removed from the air heater, remove the control from the bracket.

When replacing a capillary control be careful not to damage the capillary tube by kinking. Make bends with a generous radius (approx 25 mm).

8.6 Combustion air control/switch

If it is determined that the air differential pressure switch needs replacing, use only authorized replacements that are designed for the air heater being serviced. These switches are calibrated to operate at the designed combustion air flow duty for each appliance size in the product range.

8.7 Combustion air fan (venter)

1. Ensure gas supply to the air heater is turned OFF
2. After the air circulation fan has stopped, switch OFF the electricity supply to the air heater.
3. To gain access to the fan open the hinged controls compartment access door. refer to figure 9 for location
4. Mark for future identification and disconnect the wires connecting the fan motor at the terminals on the main wiring junction.
5. Remove combustion air fan and clean as necessary using a wire brush and solvent to remove sticky residues.
6. Re-assemble and check for free rotation before proceeding to test the appliance.

Note : the combustion air fan motor is lubricated for life. DO NOT OIL or GREASE.

👉 Fault finding may only be carried out by appropriately qualified persons

9.1 Main fault finding chart - Lock-out indicator light is "OFF", but air heater will not operate

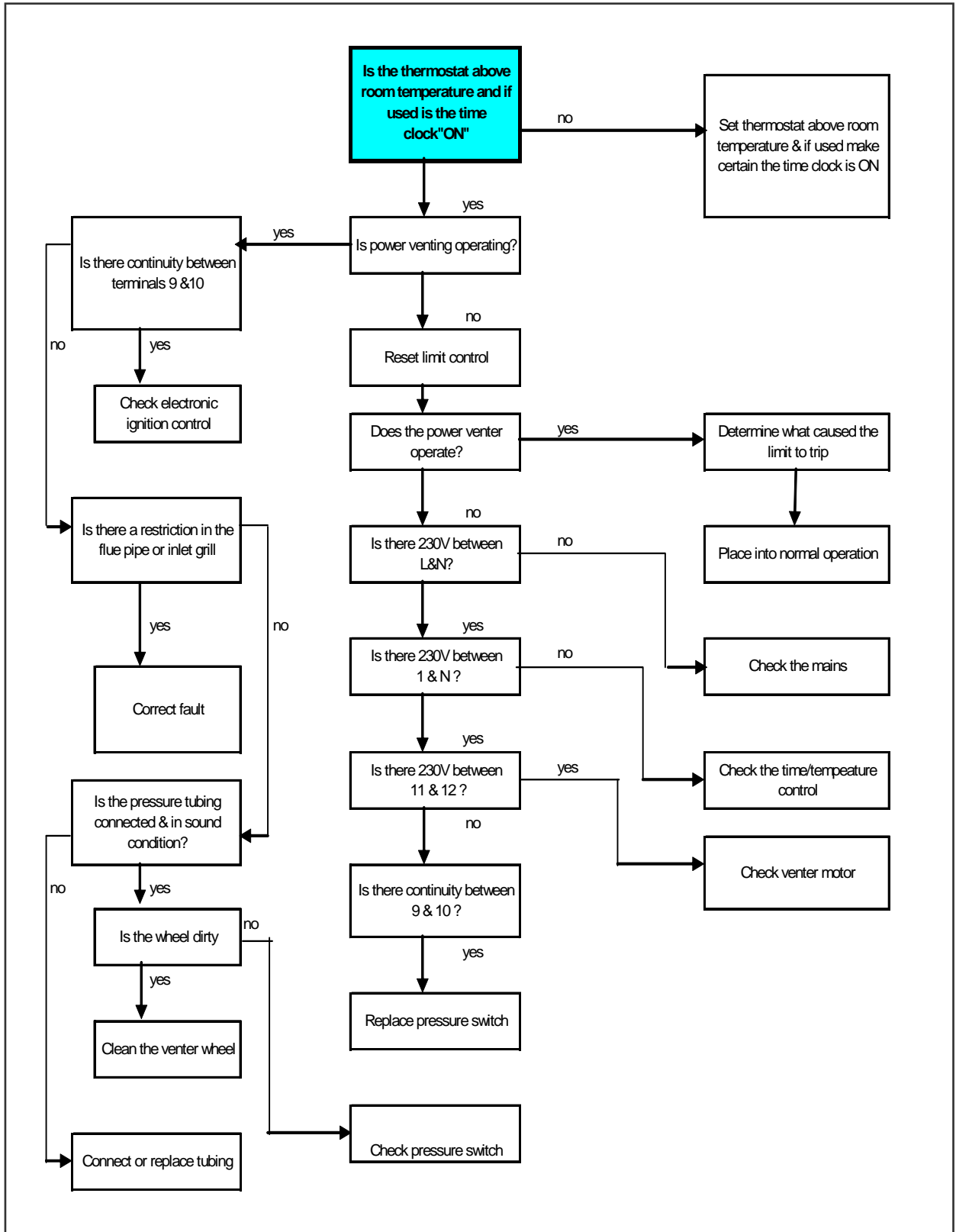

9.2 Ignition Controller Lockout indicator Light Repeatedly Comes "ON"

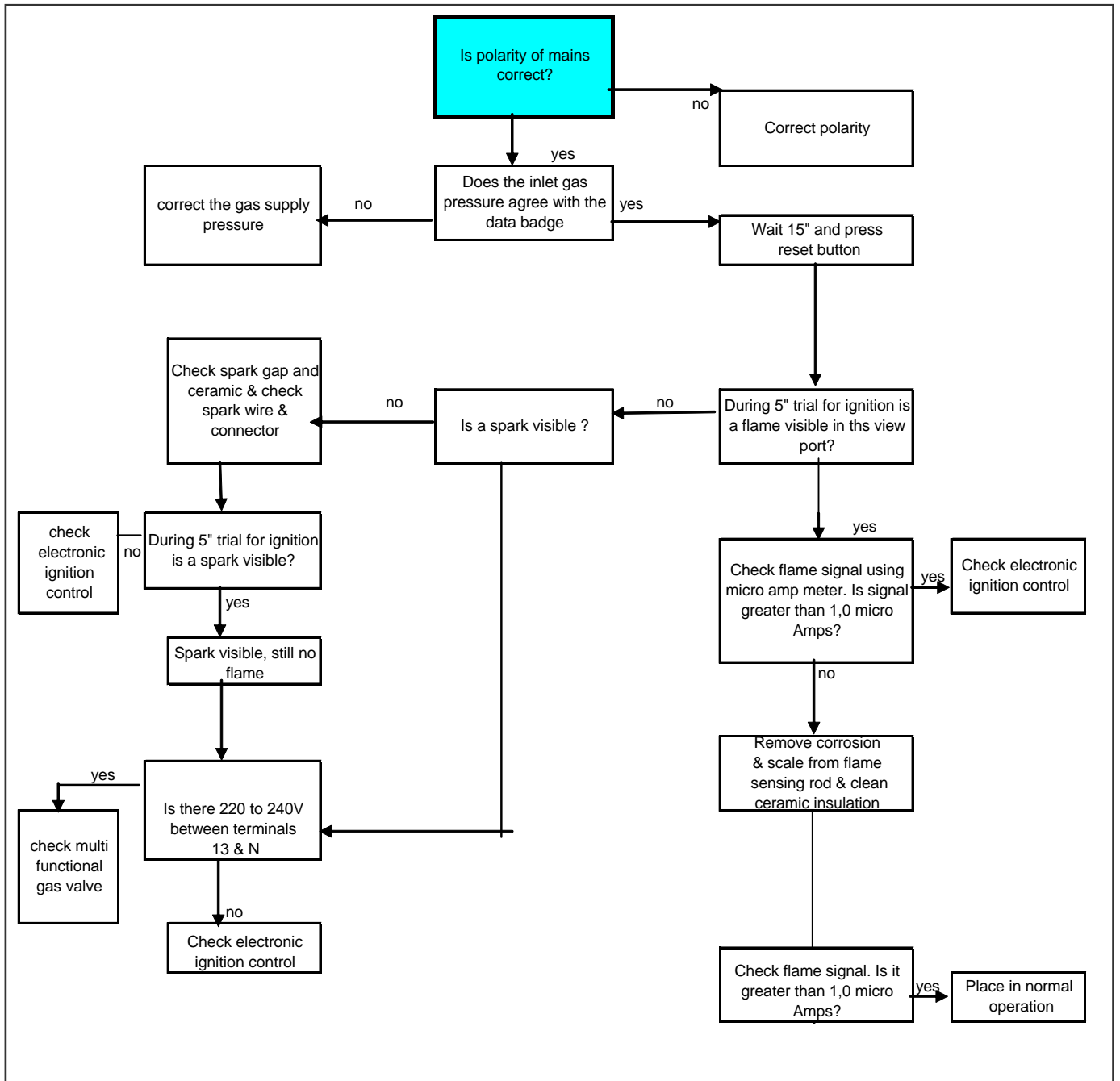

9.3 Limit Control Fault Finding Chart (limit control trips)

Note LCSA-3 air heaters are equipped with 2 limits (a recycling limit and a manual reset limit). During normal operation, neither limit should trip even if the main electric supply is interrupted during operation. In the event of motor failure, the recycling limit will trip opening the gas valve.

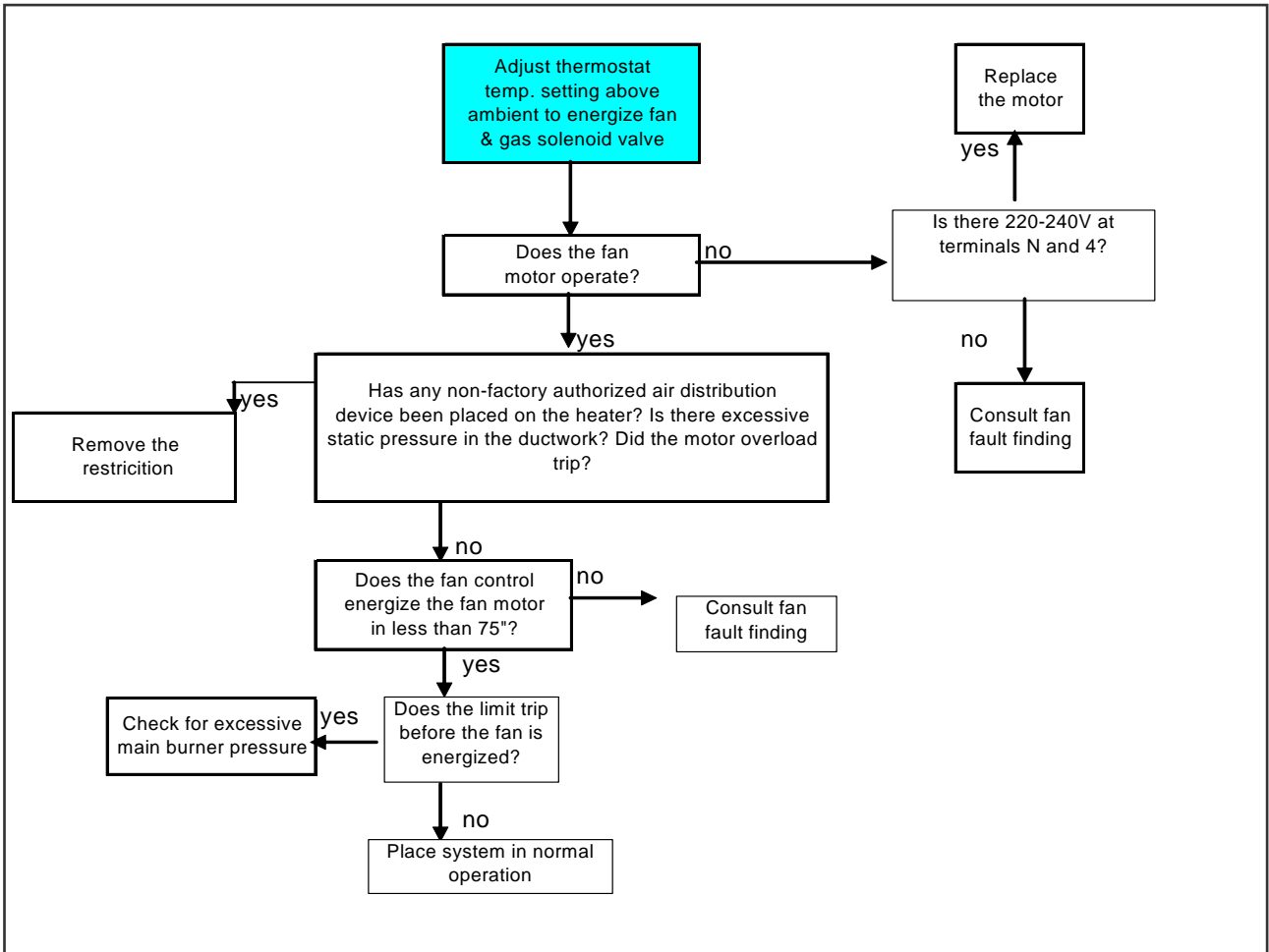

9.4 Fan Fault Finding Chart

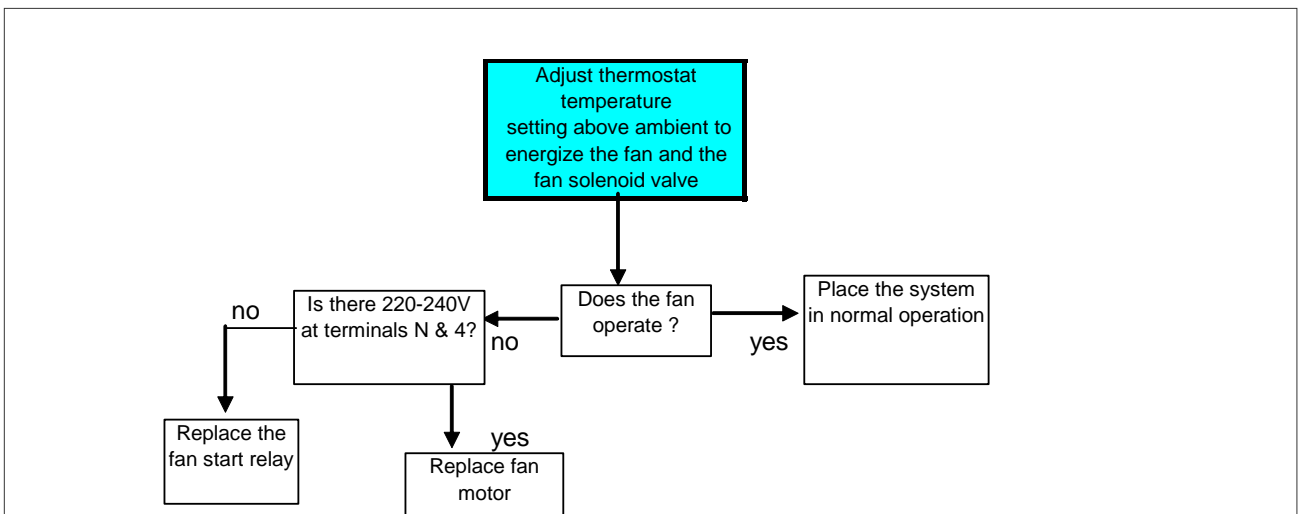

10 PARTS LISTING

Description	Part number	Settings	
Delta P switch S3: 12-3	30 60617 238	238Pa out	250Pa in
Delta P switch S3: 20-3 /30-3	30 60617 175	175Pa out	203Pa in
Delta P switch S3: 35-3/45-3 / 50-3	30 60621 155	162±7Pa out	176±7Pa in
Delta P switch S3: 60-3 / 75-3 / 100-3	30 60617 175	175Pa out	203Pa in
Delta P switch S3: 120-3/145-3	30 60617 185	185Pa out	203Pa in
Overheat control device LC1 (not 120-3/145-3)	03 24959 04	90°C out	85° C in
Overheat control device LC3 (2x) (120-3/145-3)	03 24959 03	110° C out	reset
Venter motor (all exc 120/145)	11 43426 04		
Venter motor 120-3/145-3	20 25749		
Gas valve one stage 35/45/60/75/100-3	03 25136		
Gas valve one stage 12/20/30	03 25141		
Gas valve one stage 120/145	03 25144		
Burner relay E	03 25324		
Ignition electrode ER	03 400US 42		
Ignition electrode ER (120-3/145-3)	05 25186		
Flame sensor electrode IS	03 401US 195292		
ERP fan 12-3	01 27003		
ERP fan 20-3	01 27006		
ERP fan 30-3	01 27021		
ERP fan 35-3/45-3	01 27010		
ERP fan 50-3	01 27011 01		
ERP fan 60-3/75-3	01 27013		
ERP fan 100-3	01 27014		
ERP fan 120-3/145-3	01 27012		

11 GAS CONVERSION

- 11.1 LCSA-3 air heaters are designed to operate on natural, propane or butane gas and will be supplied fitted for the gas type ordered. In the event of site conversion to a different gas type it is necessary to convert the gas burner and burner controls.
- 11.2 Affix new data plate and gas type over-sticker.
- 11.3 Upon completion of conversion re-commission the air heater in accordance with section 6 of this document.
- 11.4 Changes to carry out:
 Natural gas: use Honeywell VR4601AB (PN 03 25136) - set pressure regulator as per Table 2A
 propane: use Honeywell VR4601B (PN 03 25136B) or VR4601AB + blocking plate
- To adapt gas injectors and gas inlet pressures, we refer to table 2A/2B.

Operating:

How the air heater works:

Gas is burned by an atmospheric burner which fires into a heat exchanger. The gas burner is controlled by a double gas valve via an electronic burner control, which is actuated automatically via external controls i.e. a room thermostat and/or a time switch. The burner is ignited by a spark igniter. When the burner fires and warms the heat exchanger, the heat is sensed by a thermally actuated fan control which switches on the fan when the air temperature has reached its preset operating level.

At the end of a heating cycle the burner is switched off, the air circulation fan will continue to run until the air heater has cooled to a safe condition. Thereafter the fan will remain off until the next cycle is initiated.

Safety:

1. Flame failure is detected by the ionization probe which is the sensor and will immediately result in gas valve shut down.
2. Safety against overheating is assured by two overheat controls. The first is an automatic recycle control which protects against low air flow i.e. clogged air ways, fan failure etc. The second, which is set to a higher level than the first one, is a control which locks out and switches off the burner in the event of gross overheating for any reason. Manual intervention is necessary to reset this control device. Resetting of the automatic burner control may also be required.
3. The location of the air heater should be maintained at normal atmospheric pressure. Changes to the building after air heater installation, should have regard to the heating installation, i.e. structural changes causing excessive draughts from doors, windows etc. Other air handlers and installation of air extraction equipment which may cause a negative pressure environment, can seriously affect the operation of this type of air heater, especially if combustion air supply is not ducted.

To light the heater:

1. Turn on the gas supply to the air heater.
2. Switch on the electricity supply to the air heater.
3. Ensure time switch (if fitted) is set to an 'ON' cycle.
4. Adjust control/room thermostat to desired temperature.
5. Air heater will light automatically when the room thermostat calls for heat after about 30 sec.
6. If the appliance does not light:
 - a) check that the burner control does not require resetting. An indicator light glows at the inside panel of the appliance and on a remote control if fitted. Reset by pushing reset/button inside the appliance or the remote control.
 - b) check if thermal overheat control requires resetting

7. If the thermal overheat control requires resetting and doing so restarts the air heater, wait until the appliance warms to thermal equilibrium, to ensure the overheat control does not lock out again. If it does and the temperature near the heater is less than 30°C, then switch off the appliance and call for service. If the temperature is over 30°C, take appropriate action to reduce the ambient temperature near the air heater.

Air circulation:

1. The space heating process is for air to be circulated through the appliance whereby it gains heat from a heat exchanger. The air is directly discharged into the space to be heated. The air is eventually re-circulated. Therefore it is very important that an unobstructed path for the circulation of the air will be maintained. This is particularly important if the air heater has been installed to blow through the wall between two rooms.
2. Sometimes the air circulation fan of the appliance is connected to a remote over-ride switch. This enables air to be used for circulation purposes when the air heater is not used for heating purposes e.g. in summer. To use this feature:
 - a) switch ON electricity
 - b) switch ON manual override switch, this may be fitted as a feature on a remote composite control.

Maintenance:

1. Maintenance and service must only be carried out by appropriately qualified persons e.g. "Corgi" registered undertakings.
2. It is in your interest to ensure proper service and maintenance is carried out at a regular basis. Periods between services are dependent upon the local environment where the heater is installed. All gas appliances should be serviced at least once a year.
3. In case of any damage to the appliance, it must be shut down completely and checked by an appropriately qualified person.
4. In the event of difficulties in resolving any of these matters, please do not hesitate to contact the manufacturer or their official distributor.

NEVER SWITCH OFF ELECTRICITY SUPPLY TO THE AIR HEATER WITHOUT FIRST CLOSING THE GAS ISOLATING TAP

13.1 General

Under the Consumer Protection Act 1987 and Section 6 of the Health and Safety at Work Act 1974 we hereby provide the following information on substances hazardous to health.
Product range reference LCSA-3 air heaters.

13.2 Cautionary note

During first firing some smoking may occur, this is due to the burning off of protective/lubricating oils used during appliance production. Most of this will have been removed during the production testing process. It is a wise precaution to ensure that adequate ventilation is provided during the initial firing and throughout the commissioning period, this is particularly important if the discharge air is to blow into a confined space. This smoking does not constitute a poison hazard.

13.3 Declaration

LCSA heaters contain no asbestos; copper is not employed in gas carrying components; solder which has a melting point below 450°C is not used; paints for corrosion protection and decoration are heat cured and contain no lead.
The above appliances meet the Electrical Safety requirements of EN60 335 Pt 1 1988.

13.4 Miscellaneous

Small quantities of adhesives and sealants used in the product are dried and cured and present no known hazard.

13.5 Insulation and Seals.

Material: Alumino - silicon fiber - crane glass
Description: Tapes
Known hazards: Some people can suffer reddening and itching of the skin. Fiber entry into the eyes will cause foreign body irritation. Inhalation will cause irritation to the respiratory tract.
Precautions: Wear protective gloves when handling. People with a history of skin complaints may be susceptible to irritation.
Dust levels are only likely when the material is abraded.
In general normal handling and use for this purpose will not present discomfort. Follow good hygiene practices, wash hands before consuming food or using the toilet.
First Aid: Medical attention must be sought following eye contact or prolonged reddening of the skin.

13.6 Thermostat.

Material: Illuminating Kerosene.
Description: Sealed phial contains a small quantity in liquid form.
Recognition: Colorless liquid, paraffin oil/petroleum hydrocarbon odor.
Characteristics: Non-corrosive, flammable with no poisonous reference-CH poison Class 3
Precautions: Avoid handling. This product can irritate and defat the skin. Prolonged contact may cause dermatitis. Avoid breathing vapor. Avoid eye contact. Do not ingest.
First Aid: Skin. Wash thoroughly with soap and water.
Eyes. Rinse immediately with copious amounts of clean water.
Ingestion: Seek medical advice.

NOTE: If skin irritation persists seek medical advice.

13.7 Electrolytic Capacitor

Two types are used by random selection:
Recognition: 1. Plastic enclosure 2. Aluminium enclosure
Material: Contained liquid electrolyte
Known hazards: Electric shock possible if charged.
Precautions: Discharge to ground/earth. Do not incinerate.
First Aid: Treat for electric shock if affected.

CERTIFICATE

EC DECLARATION OF CONFORMITY OF MACHINERY (Annex II 1 A of EC Machinery Directive 2006/42/EC)

Nortek Global HVAC Belgium nv
J&M Sabbestraat 130/A000
B-8930 Menen, Belgium

Hereby declares that the following gas-fired unit heaters:

LCSA-3

Types 12, 20, 30, 35, 45, 50, 60, 75, 100, 120, 145

Complies with the requirements of the above mentioned machinery directive

*Complies with the requirements of further directives, namely
GAD 2009/142/EC - EMC 2004/108/EC – LVD 2006/95/EC*

the following harmonized standards have been applied:

EN 1020: Non-domestic gas-fired forced convection air heaters for space heating not exceeding a net heat input of 300 kW, incorporating a fan to assist transportation of combustion air and/or combustion products.

The following notified body

Technigas

Chaussée de Vilvorde 156

BE 1120 Brussels

Has been involved with regarding to the

EC type examination number E1058/5521

Menen, 01.09.2015



*J. Dubus
Engineering Team Leader*

NORTEK GLOBAL HVAC (UK) LTD

Park Farm Road
Folkestone
Kent
United Kingdom



Tel. **01303 259 250**

www.reznor.eu

Registered in England N° 1390934. Registered office: 10 Norwich Street, London, EC4A 18D

Nortek Global HVAC is a registered trademark of the Nortek Global HVAC Limited. Because of continuous product innovation, Nortek Global HVAC reserves the right to change product specification without due notice.