

The Indoor Air Economizer Feature on Model LDAP provides “free” heat. Here’s how it works...

Step 1: Wall mounted thermostat calls for heat.

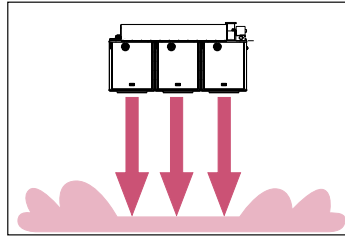

Step 2: Down discharge Model LDAP directs heating to the floor. As George Reznor used to say, “Because we live on the floor, not on the ceiling.”

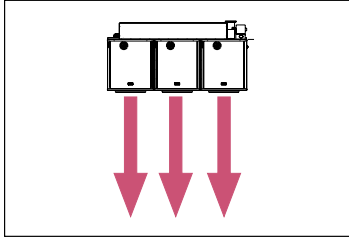
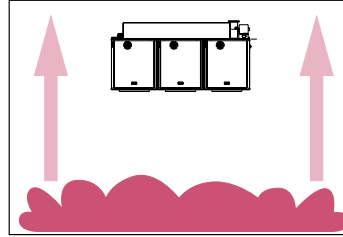

Step 3: Thermostat setting is reached, shutting off heater. Heated air naturally rises.

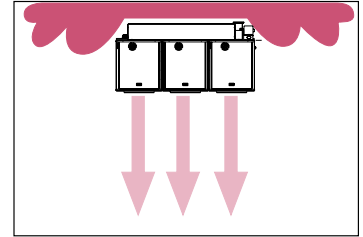

Step 4: Instead of heat remaining at the ceiling or escaping through the roof, a monitor (separate from the wall mounted thermostat) on Model LDAP senses the buildup of heat at the ceiling. This monitor triggers the fans at a slower speed to destratify the air and send “free” heat back to the floor.

Another benefit of Model LDAP: Using the fan(s) in the summer can improve working conditions by alleviating stagnant air conditions and creating a cooling effect for the occupants.

Suspending the Heater

Ceiling Suspension

WARNINGS: Check the supporting structure to be used to verify that it has sufficient load carrying capacity to support the weight of the heater. Suspend the heater only from the threaded nut retainers or with a manufacturer provided kit. Do NOT suspend from the heater cabinet.

See dimensional drawings for hanger locations, and install the ½”-13 spring nuts in the strut that is attached to the top of the unit. Comply with the requirements shown below when using threaded rod. If ordered with swivel connectors for 1” pipe, Option CK10, attach the swivels to the spring nuts according to illustration shown below and suspend with 1” pipe.

Locate the hardware kit shipped with the heater. The kit contains spring nuts, hex nuts, “U”-shape fittings, and lock washers for suspending the heater. It also includes louvers and the compression springs needed to install them.

When the heater is lifted for suspension, support the bottom of the heater with the crate bottom. If the bottom is not supported, damage could occur. After hanging or mounting, verify that any screws used for holding shipping brackets were reinstalled in the cabinet.

WARNING: All heaters must be level for proper operation. Do not place or add additional weight to the suspended heater.

Wall Mounting

Guidelines for Wall Mounting Model LDAP Heaters

- Mounting is the responsibility of the installer. Verify that the supporting structure has sufficient load-carrying capacity to support the weight.
- Prior to installation, be sure that the method of support is in agreement with all local building codes. Check for service platform requirements.
- Maintain a minimum of 2” (51mm) clearance from the discharge air openings to structural supports. Additional clearance will be required if an optional nozzle is to be field installed.
- Determining the need for installing vibration or noise isolation is the responsibility of the installer.
- To prevent potential movement, field-supplied angles must be placed around the perimeter of the heater to anchor it to the structural supports.
- Structural supports must be placed as shown to prevent damage to the heater.
- All structural supports must be noncombustible materials.

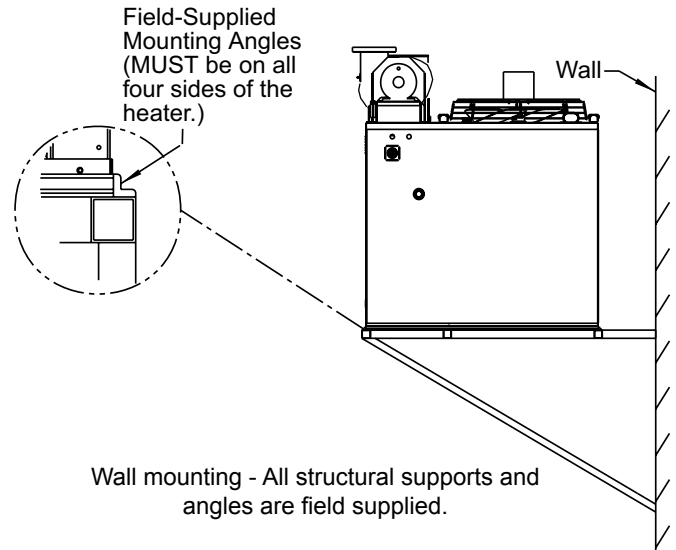

Wall mounting - All structural supports and angles are field supplied.

Options and Accessories Apply to Unit Heater Models as Listed

Stepdown Transformers - (Models F and B)

Model	Unit Size							
	25	50	75	100	125-200	250	300	400
F (heater only)	.25	.25	.25	.50	.50	.50	.50	1.00
F with Field-installed Optional Venter	.25	.50	.50	.50	.75	.50	.75	1.00
B (heater only)	.50	.50	1.0	1.0				
B with Field-installed Optional Venter	.50	.50	1.0	1.0				

Optional Polytube Outlet Adapter - Apply to Models UDBP/UDBS

Description

The optional polytube adapter is designed to adapt suspended Model UDBP and UDDBS blower type unit heaters for use with polytube ductwork. Directly in line with the heater discharge, the adapter is installed on the front of the heater and is equipped with a collar for attaching the field-supplied polytube.

The most common application of polytube ductwork for distribution of tempered air is in greenhouses. Polytubes are also used in industrial buildings to improve operating efficiency by recovering stratified air and reducing the need for complete area heating.

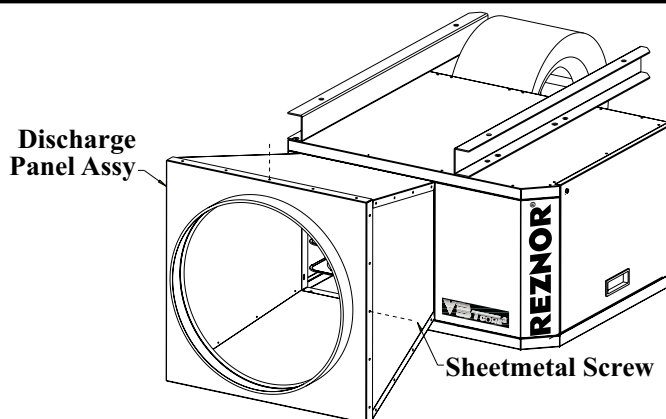

Size	CFM at 60°F Temp Rise	Polytube Diameter (inches)	Approximate Free Area (square inches)	Suggested Hole Sizes and Locations					
				Holes	Length of Polytube				
					50 Ft	75 Ft	100 Ft	125 Ft	150 Ft
75*	960	18	115	Quantity	75	75	75	75	75
				Diameter (inches)	1	1	1	1	1
				Spacing (inches)	8	12	16	20	24
100*	1345	18	160	Quantity	48	48	48	48	48
				Diameter (inches)	1 1/2	1 1/2	1 1/2	1 1/2	1 1/2
				Spacing (inches)	12 1/2	18 3/4	25	31 1/4	37 1/2
125*	1540	18	185	Quantity	50	50	50	50	50
				Diameter (inches)	1 1/2	1 1/2	1 1/2	1 1/2	1 1/2
				Spacing (inches)	12	18	24	30	36
150	1920	24	230	Quantity	40	40	40	40	45
				Diameter (inches)	2	2	2	2	1 7/8
				Spacing (inches)	15	22 1/2	30	37 1/2	40
175	2240	24	270	Quantity	50	50	80	80	80
				Diameter (inches)	1 7/8	1 7/8	1 1/2	1 1/2	1 1/2
				Spacing (inches)	12	18	15	18 3/4	22 1/2
200	2560	24	300	Quantity	50	50	50	50	50
				Diameter (inches)	2	2	2	2	2
				Spacing (inches)	12	18	24	30	36
225	2880	24	340	Quantity	42	42	42	42	42
				Diameter (inches)	2 1/4	2 1/4	2 1/4	2 1/4	2 1/4
				Spacing (inches)	14	21	28	35	42
250	3200	24	380	Quantity	50	50	50	60	60
				Diameter (inches)	2 1/4	2 1/4	2 1/4	2	2
				Spacing (inches)	12	18	24	25	30
300	3840	24	460	Quantity	60	60	75	75	75
				Diameter (inches)	2 1/4	2 1/4	2	2	2
				Spacing (inches)	10	15	16	20	24
350	4480	24	540	Quantity	50	50	50	50	50
				Diameter (inches)	2 1/2	2 1/2	2 1/2	2 1/2	2 1/2
				Spacing (inches)	12	18	24	30	36
400	5120	24	600	Quantity	60	60	75	75	75
				Diameter (inches)	2 1/2	2 1/2	2 1/4	2 1/4	2 1/4
				Spacing (inches)	10	15	16	20	24

* Required direct drive blower speed.

Size	Speed
75	Low
100	Low
125	Medium

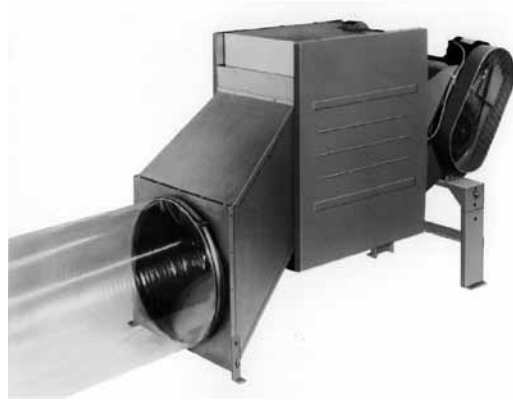

Photograph shows polytube outlet. The outlet nozzle requires field assembly and installation on the standard unit in place of the top front panel and louvers. The heater manufacturer does not supply tubing. Tubing can be ordered from a local greenhouse supply distributor. Two such suppliers are FOF Products, Inc. P. O. Box E, 1505 Racine Street, Delevan, WI 53115 and ACME Engineering Co., P.O. Box 978, Muskogee, OK 74402.

Optional Polytube Outlet Adapter - Apply to Model B

Description

The optional outlet nozzle is designed to allow the attachment of polytube-type air distribution for use in greenhouse and industrial buildings. Outlet on suspended heater may be either above, below, or directly in line with the heater discharge. A kit is available to floor mount the heater with outlet below the heater discharge (see illustration). Model B standard blower and drive are designed to handle rated CFM at .25 w.c. ESP, and will inflate a 24" tube up to 150 ft. long. See table for proper free area, minimum number of holes and sizes. Units may be used for greenhouse heating and ventilating or in industrial applications requiring high mounting heights or spot heating by means of polytube distribution.

The total open or free area of the polytube is important. Polytube suppliers have a great deal of flexibility in placement and sizing of holes. Too small of a free area will cause overheating. Excessive open area may not permit the tube to inflate. See the table below for a guide in hole size and location. Spacing and hole size may be varied, but free area must not be less than shown for the heater being installed.

Greenhouse Application - For greenhouse use, the number of units required is generally based on an airflow volume of 1-1/2 to 2 CFM per square foot of house floor area. Depending on the heat loss requirements of the house type, location, and desired temperature above ambient, the ventilation requirements determine the number of distribution systems required and the heat loss determines the BTUH heater size required. As a general rule, a single system will serve a maximum house width of 30 ft. and a length of 150 ft.

Size	CFM at .25" ESP	Polytube Diameter (inches)	Minimum Free Area (sq. in.)	Suggested Hole Sizes and Locations					
				Holes	Length of Polytube				
					50 Ft	75 Ft	100 Ft	125 Ft	150 Ft
75	925	18	110	Number	37pairs	75 pairs	75 pairs	--	--
				Diameter	1-1/2"	1"	1"	--	--
				Spacing	16"	12"	16"	--	--
100	1235	18	145	Number	50 pairs	50 pairs	100 pairs	94 pairs	--
				Diameter	1-1/2"	1-1/2"	1"	1"	--
				Spacing	12"	18"	12"	16"	--
125	1540	18	185	Number	40 pairs	60 pairs	60 pairs	125 pairs	--
				Diameter	1-7/8"	1-1/2"	1-1/2"	1"	--
				Spacing	15"	15"	20"	12"	--
130	1600	24	190	Number	40 pairs	60 pairs	60 pairs	125 pairs	--
				Diameter	1-7/8"	1-1/2"	1-1/2"	1"	--
				Spacing	15"	15"	20"	12"	--
165	2035	24	240	Number	50 pairs	50 pairs	75 pairs	75 pairs	75 pairs
				Diameter	1-7/8"	1-7/8"	1-1/2"	1-1/2"	1-1/2"
				Spacing	12"	18"	16"	20"	24"
200	2465	24	300	Number	42 pairs	42 pairs	60 pairs	60 pairs	100 pairs
				Diameter	2-1/4"	2-1/4"	1-7/8"	1-7/8"	1-1/2"
				Spacing	14"	21"	20"	25"	18"
250	3085	24	360	Number	40 pairs	60 pairs	60 pairs	60 pairs	60 pairs
				Diameter	2-1/2"	2"	2"	2"	2"
				Spacing	15"	15"	20"	25"	30"
300	3700	24	425	Number	75 pairs	75 pairs	75 pairs	75 pairs	75 pairs
				Diameter	2"	2"	2"	2"	2"
				Spacing	9"	12"	16"	20"	24"
400	4935	24	550	Number	60 pairs	60 pairs	60 pairs	100 pairs	100 pairs
				Diameter	2-1/2"	2-1/2"	2-1/2"	1-7/8"	1-7/8"
				Spacing	10"	15"	20"	15"	18"

CAUTION: To prevent overheating of the blower unit heater and to ensure correct air distribution, the minimum hole area must be provided as shown in the table for each size. If more holes are used, do not exceed 1.25 times the minimum area shown to ensure proper tube inflation.

Diameter of the Hole (inches)	Area of the Hole (square inches)
2-1/2	4.91
2-1/4	3.98
2	3.14
1-7/8	2.76
1-1/2	1.76
1	0.785

Optional Downturn Nozzles - Apply to Models UDAP, UDAS, UDBP, UDBS, UEAS, F and B

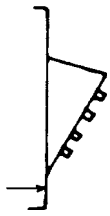

Optional Downturn Nozzle with 25°-65° Range of Air Deflection

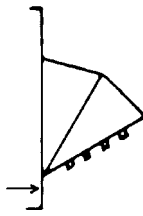

Optional Downturn Nozzle with 50°-90° Range of Air Deflection

IMPORTANT: On fan Models UDAP, UDAS, UEAS and F, do not use optional vertical louvers in combination with a nozzle with 50-90° range of air deflection.

* Shipped separately for field assembly and installation

Model OT Oil Tank - Apply to Models OH

DESCRIPTION

The Model OT250 fuel tank is a 250 gallon, single-wall, indoor, UL-listed fuel oil tank. Oil tanks often eliminate needed work and storage space, but the Model OT-250 oil tank is designed with a work bench top that allows the tank itself to be used as a work area. The tank has a large (12-1/2 sq. ft.) work surface with 2" side and rear retainer lips and 3" legs for "toe space".

Tank construction is of 12 gauge carbon steel with all welded seams. The painted exterior coordinates with Reznor® oil-fired heaters.

The Reznor® OT-250 fuel tank is also engineered to facilitate installation. The support legs provide convenient space for forklift handling. Each tank has the following connection ports -- 2" supply; 2" gauge; 2" vent; 4" emergency vent; and 1" drain. Each port has heavy duty forged threads.

Model OT-250 tank is UL listed to UL142 Standard.

OPTIONS/ACCESSORIES - Field Installed

- Heater stand for Model OT tank used with Model OH heater only

DIMENSIONS - Model OT Fuel Tank

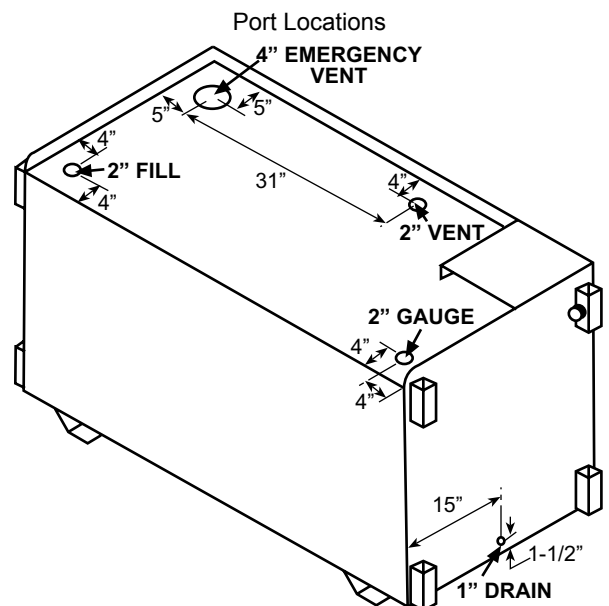
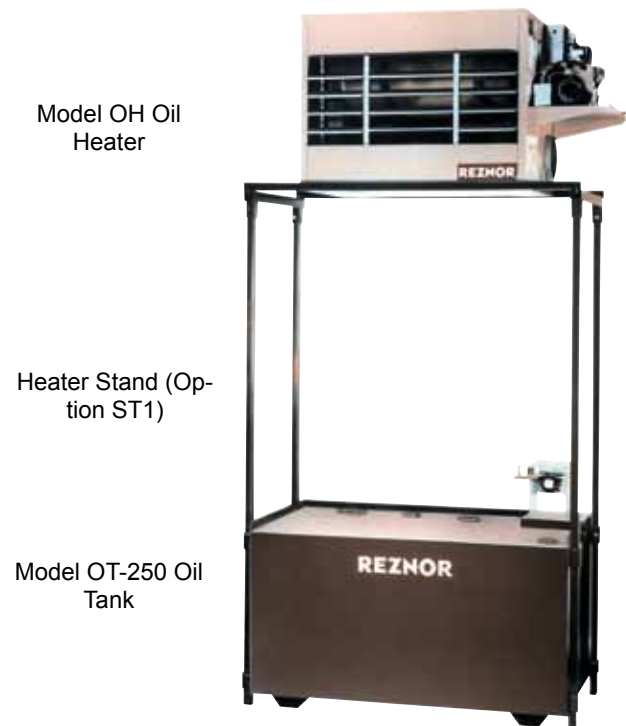
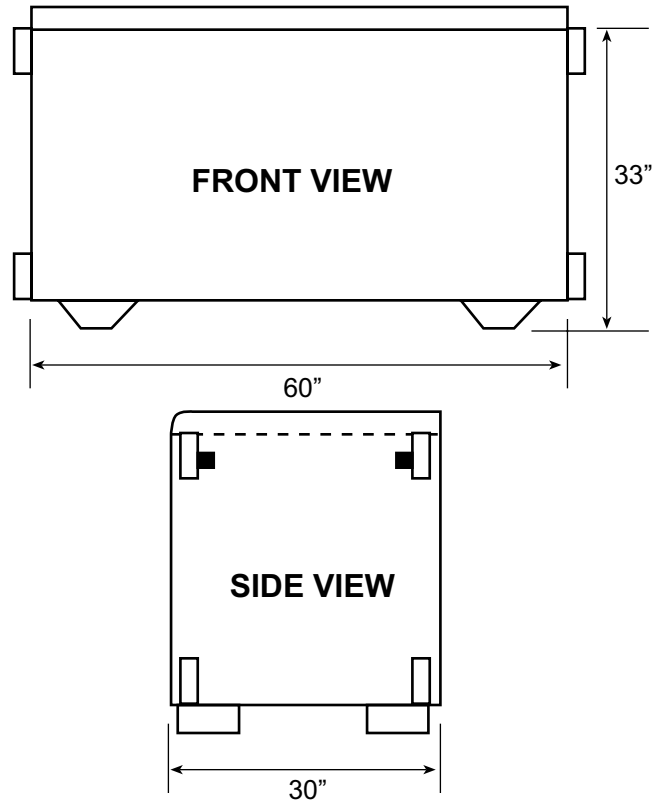

Model LDAP Discharge Air Options

LOUVERS

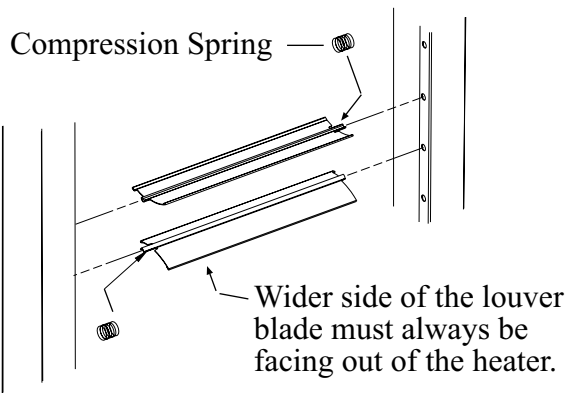

Airflow direction depends on how the louvers are installed

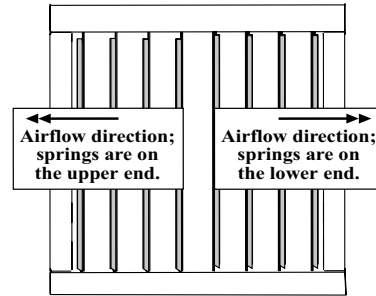

INSTALLING LOUVERS

After the unit is suspended/mounted, install the air directional louvers or optional nozzle. If an optional nozzle is being installed, follow the instructions included with the nozzle. If a nozzle is not being used, install the louvers in the discharge opening(s).

Louvers and springs are in the hardware kit shipped with the heater.

Before actually installing the louvers, note the louver curve and determine how the louvers should be positioned to provide the optimal throw pattern. Opening is square so louvers may be installed in any direction. Louvers may be installed with the curve all the same direction (either way) or the right half one way and left the other as illustrated above.

LOUVER INSTALLATION INSTRUCTIONS

- 1) With the wider section of the louver facing out of the heater, place one of the compression springs over the tab on the notched end of a louver. The end of the louver with the spring will fit in any direction in the square opening. How the louver turns depends on which end of the louver is inserted first.
- 2) Depending on the throw pattern selected, push the louver tab with the spring into a hole in the discharge opening and insert the louver tab on the other end into the corresponding hole on the opposite side.
- 3) Airflow direction depends on how the louvers are installed (see illustration above).

FOUR-WAY DISCHARGE LOUVERS (Option CD32)

Option CD32 consists of additional louvers that are installed perpendicular to the standard individually adjustable louvers. By installing the optional perpendicular louvers, the two sets of louvers can be adjusted to direct airflow in any of the four directions, enabling the installer to select and increase or decrease the coverage area.

MULTIPLE POSITION DISCHARGE NOZZLE

Option CD57 is a 30° angle discharge nozzle. Option CD58 is a 60° angle discharge nozzle. Option CD59 is a 30° angle discharge nozzle with 4-way louvers. A nozzle may be installed at each discharge air opening in any direction. **NOTE:** Do not install 4-way louvers with a 60° nozzle.

Nozzles should be attached after the unit is suspended. Follow the installation instructions in the nozzle package.

Standard louvers are installed in the nozzle opening as shown in the photo on the left.

Option CD58,
60° Discharge Nozzle

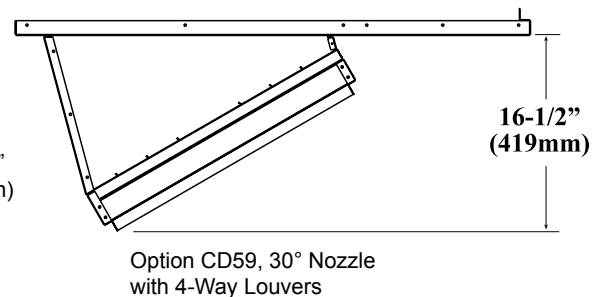
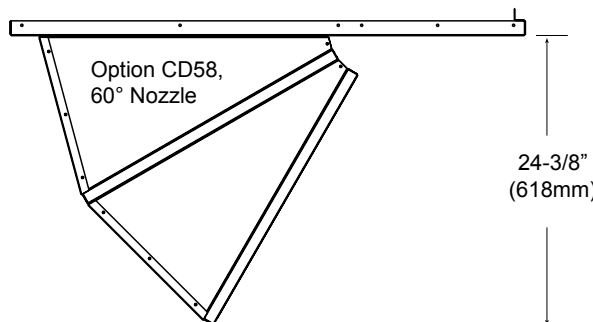
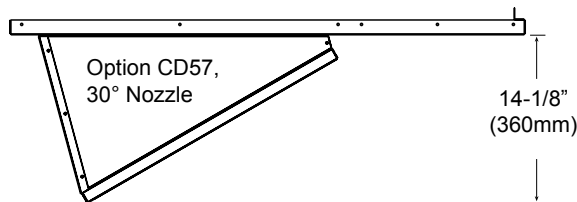



Reznor Separated Combustion Systems

Following is an overall description of Separated Combustion Systems as it relates to Models UDAS and UDBS. For more specific separated combustion venting information, especially as it relates to Model UEAS, please see the appropriate installation manual.

The manufacturer of Reznor heating equipment, for years, has pioneered in separated combustion system technology, eliminating "open flame" combustion problems. This has resulted in a complete line of Reznor products using the separated combustion principle-

- air for combustion is mechanically induced from outside the building, preventing dirt, lint, dust or other contaminants in the indoor atmosphere from entering the burner and combustion zone of the furnace,
- the air flow is metered to provide optimum and efficient combustion that is unaffected by negative building pressure or wind,
- after combustion, the air is exhausted back to the outdoor atmosphere.

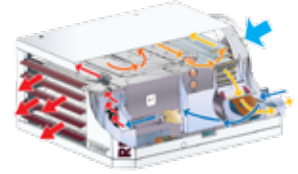

Reznor separated combustion products provide all of the benefits while requiring only one building penetration. See the venting illustrations below.

Use only approved vent terminals. No other venting arrangements are approved or certified for use with Models UDAS, UDBS or UEAS heaters. Either the horizontal vent/combustion air terminal kit (Option CC6 or Option CC14) or the vertical vent/combustion air terminal kit (Option CC2) is required.

Refer to Venting Installation Manual Form I-UD-V-SC for Models UDAS and UDBS; Form I-UEAS for Model UEAS. Or contact your Reznor Representative at 800-695-1901 for more detailed information.

For installations where dirt, dust, and other air borne contamination is present in the indoor environment, it is recommended to use separated combustion units (UDAS, UDBS). These models use air from outside the space for combustion. This will help reduce the build up of contaminants on the burner which would affect the combustion process. Refer to the installation manuals for recommended frequency of maintenance and cleaning.

Vertical Venting of Separated Combustion Unit through Roof

- See the illustration to the right for a typical installation of one vertical vent terminal and concentric adapter. If vertical vent (Option CC2) is selected, a vertical vent terminal/combustion-air inlet assembly is provided.

NOTE: Illustration for typical installation example only. Vent terminals may vary based on heater size and model.

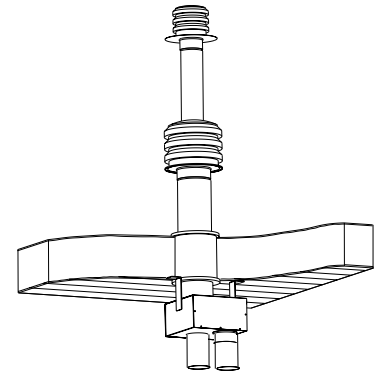

Horizontal Venting of Separated Combustion Unit through Wall

- See the illustration to the right for a typical installation of a single horizontal vent terminal and concentric adapter. When Option CC6 is ordered, one horizontal vent terminal/combustion air inlet assembly is provided.

NOTE: Illustration for typical installation example only. Vent terminals may vary based on heater size and model.

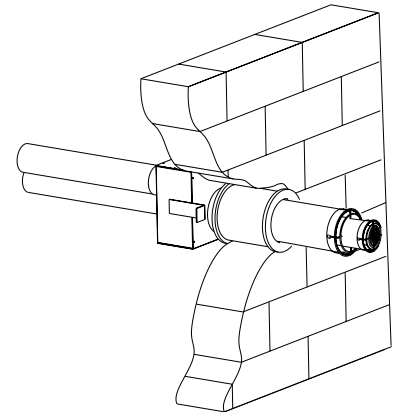

Residential Garage - Horizontal Venting of Separated Combustion Unit through Wall

(Models UDAS and UDBS Only)

Option CC14, the Compact, Aesthetic, Concentric Vent/Combustion Air, Horizontal Vent Kit is for use with Model UDAS and UDBS in sizes 30, 45, 60, and 75.

The most common use for these vent kit is for Model UDAS for residential garage installations. This option allows a homeowner to vent out a side wall and avoid the unsightly 18" to 36" exhaust vent. This attractive vent kit preserves the home's exterior appearance.

For more information, contact your Reznor Representative at 800-695-1901, or see the instruction manual Form I-UDAS/UDBS-ASC.

NOTE: Siding trim is field-supplied by contractor to match home appearance.

