



UDSA-4



Gas fired Balanced flue / Fan assisted flue unit heater

INSTALLATION COMMISSIONING SERVICING

Applies to

Belarus, Bulgaria, China, Czech Republic, Croatia, Cyprus, Denmark, Estonia, Finland, Greece, Hungary, Iceland, Latvia, Lebanon, Lithuania, Montenegro, New Zealand, Norway, Poland, Portugal, Romania, Russian Federation, Serbia, Slovakia, Slovenia, Spain, Sweden, Turkey,



These appliances meet the following EC Directives:

DIR 2009/142/EC:GAD

DIR 2004/108/EC:EMC

DIR 2006/95/EC: LVD

DIR 2006/42/EC:MD

WARNING

Please read this document carefully before commencing installation, commissioning and/or servicing.

Leave it with the user or attached to the appliance or gas service meter after installation.

Improper installation, adjustment, alteration, service or maintenance can cause property damage, injury or death. All work must be carried out by appropriately qualified persons.

The manufacturer does not take any responsibility in the event of non-observance of the regulations concerning the connection of the apparatus causing an evil operation possibly resulting in damage to the apparatus and/or environment in which the unit is installed.

INDEX

Warnings	3
1. General	4
2. Installation codes	4
3. Warranty	4
4. Uncrating and preparation.....	4
5. Dimensions	5
6. Technical data	6
7. Flueing requirements	8
8. Unit heater location.....	12
9. Hanging the unit.....	13
10. Gas piping and pressures	15
11. Electrical supply and connections.....	16
12. Check installation and start up.....	17
13. Maintenance schedule.....	22
14. Heat exchanger maintenance	23
15. Burner maintenance	24
16. Burner orifice	26
17. Ignition system.....	26
18. Fan motor	27
19. Venter motor and wheel	28
20. Gas valve.....	30
21. Combustion air pressure switch.....	31
22. Limit controls.....	31
23. Flue and combustion air system.....	32
24. Troubleshooting	32
25. Parts list.....	37

Warnings

FOR YOUR SAFETY

What to do if you smell gas:

- Do not try to light any appliance.
- Do not touch any electrical switch; do not use any phone in your building.
- Immediately call your gas supplier.
- Evacuate all personnel.

FOR YOUR SAFETY

Do not store or use petrol or other flammable vapours and liquids in the vicinity of this or any other appliance.

WARNING: Improper installation, adjustment, alteration, service, or maintenance can cause property damage, injury, or death. Read the installation, operation, and maintenance instructions thoroughly before installing or servicing this equipment.

WARNING : Gas-fired appliances are not designed for use in hazardous atmospheres containing flammable vapors or combustible dust, in atmospheres containing chlorinated or halogenated hydrocarbons or in applications with airborne silicone substances.

WARNING : Should overheating occur, or the gas supply fail to shut off, shut off the manual gas valve to the appliance before shutting off the electrical supply.

WARNING : Do not use this appliance if any part has been immersed in water. Immediately call a qualified service technician to inspect the appliance and replace any gas control that has been immersed in water.

WARNING : This appliance is not intended for use by persons (including children) with reduced sensory or mental capabilities or lack of experience and knowledge, unless they have been given supervision or instruction concerning use of the appliance by a person responsible for their safety. Children should be supervised to ensure that they do not play with the appliance.

1. General

Models UDSA-4 are design certified to the CE EN1020 standard for use in industrial and commercial installations only. All models and sizes are available for use with either natural or propane gas. The type of gas, the input rate and the electrical supply requirement is shown on the heater rating plate. Check the rating plate to determine if the heater is appropriate for the intended installation.

This installation manual is shipped with the heater. Verify that the literature is correct for the heater being installed. If the manual is incorrect for the heater, contact the supplier before beginning installation.

The instructions in this manual apply only to the models listed.

Installation should be done by a suitably qualified installer in accordance with these instructions. The installer is responsible for the safe installation of the heater.

2. Installation codes

These units must be installed in accordance with BS6230 or BS5440 as appropriate plus all local building codes.

3. Warranty

Warranty is void if :

- a. Wiring is not in accordance with the diagram furnished with the heater.
 - b. The unit is installed without proper clearances as soon as clearances are required regardless of the material being combustible.
 - c. A fan model is connected to a duct system or if the air delivery system is modified.
-

4. Uncrating and preparation

This unit was test operated and inspected at the factory prior to crating and was in proper operating condition. If the heater has incurred damage in shipment, document the damage with the transport company and contact your supplier.

Check the rating plate for the gas and electrical specifications of the heater to be sure that they are compatible with the gas and electric supplies at the installation site.

Read this booklet and become familiar with the installation requirements of your heater. If you do not have knowledge of local requirements, check with the gas supplier and any other local agencies who might have requirements concerning this installation.

Before beginning, make preparations for necessary supplies, tools, and manpower. **If the installation includes optional vertical louvers or downturn nozzle etc., install these options before the heater is suspended. Follow the instructions included in the option package.**

5. Dimensions & Clearances (horizontal orientation = standard)

Figure 1

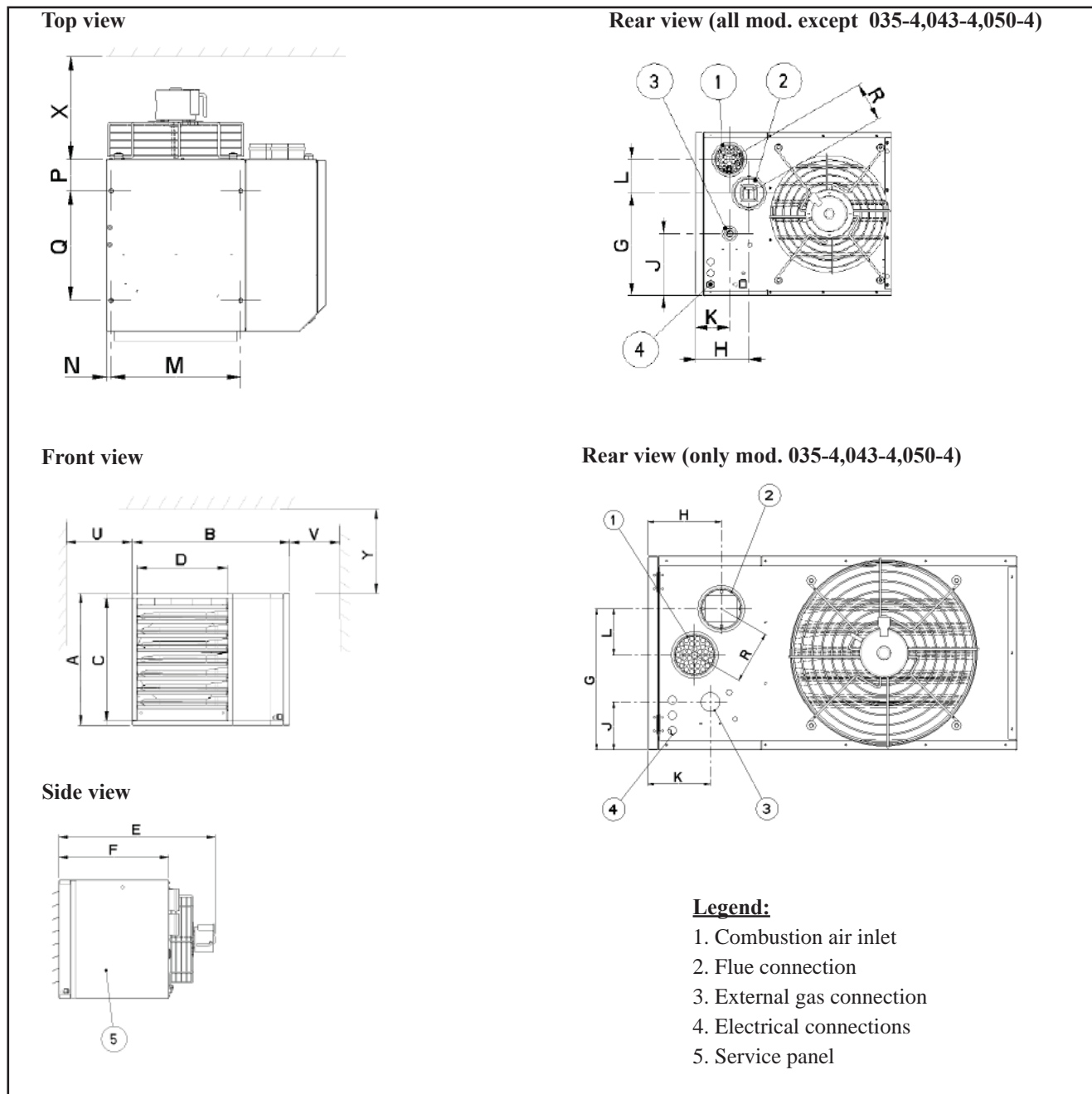

Table 1 : Dimensions (mm)

UDSA-4	A	B	C	D	E	F	G	H	J	K	L	M	N	P	Q	R
008-011	307	700	267	404	696	546	131	191	129	67	85	413	15,5	98	350	120
015-020	383	700	343	404	723	546	199,5	191	139	122	86	413	15,5	98	350	120
025-030	586	700	546	404	771	546	367,5	191	222	122	121	413	15,5	98	350	140
035-050	510	970	456	601	1033	897	371	194	126	158	121	622	33	149	600	140
055-064	663	970	609	601	1052	897	354	206	150	165	204	622	33	149	600	225
073	866	1040	812	651	1036	897	562	212	299	185	204	672	33	149	600	225
085	866	1040	812	651	1139	897	562	212	299	185	204	672	33	149	600	225
100	866	1040	812	651	1097	897	562	212	299	185	204	672	33	149	600	225

Clearances (mm) Units must be installed so that the minimum clearances in the following table are provided for combustion air space, inspection and service and for proper spacing from combustible materials.

Table 2 : Clearances (mm)

Model	X	Y	Z (*)	U	V
008-4 → 030-4	450	50	50	50	850
035-4 → 100-4	450	100	100	100	850

(*) : Heaters can be base mounted on suitable non combustible supports.

Attention :

The clearance distance from the flue system must be minimum 150mm at all points !

Combustion air supply and flue system diameters

Diameter gas connection

Table 3 :

UDSA-4	008	011	015	020	025	030	035	043	050	055	064	073	085	100
Dia flue/air inlet (mm)	80	80	80	80	100	100	100	100	100	130	130	130	130	130
Dia gas connection	1/2"	1/2"	1/2"	1/2"	1/2"	1/2"	3/4"	3/4"	3/4"	3/4"	3/4"	3/4"	3/4"	3/4"

6. Technical data

Table 4a : Gas category

Country	Gas category
Belarus	II2H3+
Bulgaria	I2H or I3B/P
China	II2H3+
Czech Republic	II2H3+
Croatia	II2H3P
Cyprus	II2H3+
Denmark	II2H3 B/P
Estonia	II2H3+
Finland	II2H3 B/P
Greece	II2H3+
Hungary	II2HS3P
Iceland	II2H3+
Latvia	II2H3+
Lebanon	II2H3+
Lithuania	II2H3+
Montenegro	II2H3+
New Zealand	II2H3+
Norway	II2H3 B/P
Poland	I2ELw3P
Portugal	II2H3+
Romania	II2H3P
Russian Federation	I2H or I3P
Serbia	II2H3+
Slovakia	II2H3+
Slovenia	II2H3+
Spain	II2H3+
Sweden	II2H3 B/P
Turkey	II2H3+

Table 4b : Technical data

Model		008-4	011-4	015-4	020-4	025-4	030-4	035-4	
Combustion air and flue, type B instal. (1)		B22							
Combustion air and flue, type C instal. (1)		C12, C32, C52, C82 (C62 enkel voor Nederland)							
Flue & combustion air connection collars	mm	80	80	80	80	100	100	100	
Heat input (Hs)	kW	8,8	13,2	17,6	22,0	30,8	35,2	41,8	
Heat input (Hi)	kW	7,9	11,9	15,9	19,8	27,8	31,7	37,7	
Heat output	kW	7,3	11,0	14,6	18,2	25,5	29,2	34,7	
Thermal efficiency	%	92	92	92	92	92	92	92	
Gas consumption	nat gas G20	m³/h	0,84	1,26	1,68	2,10	2,94	3,36	3,99
	nat gas G27 (*)	m³/h	0,98	1,46	1,95	2,44	3,42	3,90	4,64
	prop G31	kg/h	0,62	0,93	1,24	1,55	2,16	2,47	2,94
Gas connection size (not supply line) (2)		1/2"							3/4"
Temperature rise	K	32	32	32	32	32	32	29	
Air flow	m³/h	680	1020	1360	1700	2385	2725	3510	
Motor speed	rpm	1390	1390	1450	1450	930	1250	920	
Recommended mounting height(3)	m	3	3	3	3	4	4	4	
Horizontal throw(4)	m	8	10	13	16	20	25	25	
Sound pressure (5)	dB(A)	47	46	47	48	43	49	44	
Electrical service (class IP20)		230/240V 1N ~ 50Hz							
Total electrical rating	W	121	121	126	126	273	270	290	
Weight (net)	kg	30	33	38	40	54	57	86	

Model		043-4	050-4	055-4	064-4	073-4	085-4	100-4	
Combustion air and flue, type B instal. (1)		B22							
Combustion air and flue, type C instal. (1)		C12, C32, C52, C82 (C62 enkel voor Nederland)							
Flue & combustion air connection collars	mm	100	100	130	130	130	130	130	
Heat input (Hs)	kW	50,8	58,6	66,0	77,7	88,0	102,7	117,3	
Heat input (Hi)	kW	45,8	52,8	59,5	70,0	79,3	92,5	105,7	
Heat output	kW	42,1	48,6	54,7	64,4	73,0	85,1	97,0	
Thermal efficiency	%	92	92	92	92	92	92	92	
Gas consumption	nat gas G20	m³/h	4,85	5,59	6,30	7,41	8,39	9,79	11,18
	nat gas G27 (*)	m³/h	5,64	6,50	7,32	8,62	9,76	11,38	13,00
	prop G31	kg/h	3,57	4,12	4,64	5,46	6,18	7,21	8,24
Gas connection size (not supply line) (2)		3/4"							
Temperature rise	K	28	28	28	28	28	28	28	
Air flow	m³/h	4535	5180	5830	6810	7770	9065	10360	
Motor speed	rpm	910	1360	940	930	900	890	1050	
Recommended mounting height(3)	m	4	4	4	4	4	4	4	
Horizontal throw(4)	m	28	32	35	33	41	41	39	
Sound pressure (5)	dB(A)	45	56	51	52	54	55	60	
Electrical service (class IP20)		230/240V 1N ~ 50Hz							
Total electrical rating	W	290	500	500	500	770	770	960	
Weight (net)	kg	99	102	114	118	143	160	179	

(*) : G27 only for Poland

- 1) Gas Appliance Classifications for Approved Venting Methods based on CEN-report CRI749:2001.
- 2) There is a difference between the gas connection diameter and the diameter of the supply line. Always use the most adequate dia of the supply line to minimize the pressure drop through the gas pipes - if necessary, reduce the diameter of the supply line at the inlet of the unit.
- 3) Height from floor to bottom surface of heater. These are recommendations only. Positioning of unit heaters for proper performance is application dependent. Operation is affected by other air moving equipment in the space, obstructions to the airflow, draughts and/or close proximity to doors or windows, etc ... **Care should be taken to avoid mounting the heaters above these recommendations, unless downturn nozzle options are used, as significant stratification may occur resulting in poor floor coverage and higher energy losses through the roof structure.**
- 4) Isothermal conditions +/-20°C ambient air temperature, discharge louvres zero deflection, v = 0,5m/s. The air throw will be influenced by the height of the building, mounting height of the unit, ambient temperature & adjustment of the louvres.
- 5) Sound pressure measured in dB(A) : at 5m distance of the heater with A=160m² & Q=2

7. Flue requirements

Model UDSA-4 heaters may be installed as Type-B and Type-C installations.

Flue must be in accordance with BS6230 or BS5440. Local requirements may apply in addition to national requirements. These unit heaters are designed to operate safely and efficiently with either a horizontal or vertical flue system when installed with the specific requirements and instructions.

If this heater is replacing an existing heater, be sure that the flue is sized properly for the heater being installed and that the existing flue is in good condition. A properly sized flue system is required for safe operation of the heater. An improperly sized flue system can cause unsafe conditions and/or create condensation.

The air heaters may be installed as a balanced flue (type C) heater requiring both a combustion air inlet duct and a flue pipe or as a power vented heater (type B) (the combustion air is taken from the space where heater is installed), which requires only a flue pipe exhausting to outdoors.

All products of combustion must be flued to outdoor atmosphere.

Each heater installed as a type B appliance must be fitted with an individual flue pipe and the combustion air inlet opening is provided with a protection grill. Each heater installed as a type C appliance must be fitted with an individual combustion air/flue pipe system. Type C2 appliance, with single duct system for supply of combustion air and evacuation of flue gasses, are not allowed.

IMPORTANT :

The flue must be installed in accordance with national and local regulations. Failure to provide proper flueing could result in death, serious injury and/or property damage. The air heater must be installed with a flue to the outside of the building. Safe operation of any power vented gas apparatus requires a properly operating flue system, correct provision for combustion air and regular maintenance and inspection.

Diameter & maximum flue pipe lengths

Table 5 : maximum flue system pipe lengths

Flue pipe diameters and maximum pipe lengths in table 5 apply to both **horizontal** and **vertical** systems. Add **all** straight sections and equivalent lengths for elbow.

The total combined length **must not exceed** the maximum flue length.

Model UDSA		008-4 → 020-4	025-4 → 050-4	055-4 → 100-4	
Heater socket & pipe dia	mm	flue pipe	80	100	130
		inlet pipe	80	100	130
Max. straight length (with wall/roof terminal)	m	flue pipe	9*	9*	9*
		inlet pipe	9*	9*	9*
Equivalent length of 45° elbow	m	flue pipe	0.75	0.75	0.75
		inlet pipe	0.75	0.75	0.75
Equivalent length of 90° elbow (3-segment elbow)	m	flue pipe	1.5	1.5	1.5
		inlet pipe	1.5	1.5	1.5
Equivalent length of 90° elbow (dia 80mm, 1-segment elbow)	m	flue pipe	2.5	2.5	n.a
		inlet pipe	2.5	2.5	n.a

- Use only one flue pipe diameter on an installation.
- Recommended minimum flue is 1m.
- * Mentioned lengths only apply when :
 - no elbow installed immediately after flue and inlet
 - successively installation of several elbows without straight pipe

Flue outlet

Venter outlet attachment requirements:

Depending on the size of flue pipe as determined in table 5, attach either the flue pipe directly to the collar or a taper-type connector.

WARNING :

Single wall flue pipe exposed to cold air or run through unheated areas should be insulated to avoid condensation. Provision must be made for the condensation to flow freely to a point to which it can be released, i.e. a drain or gully. The condensation drain from the flue must be constructed from non-corrodible material not less than 20 mm diameter. Copper or copper based alloys must not be used for condensation drains.

For testing, the flue pipe should include a sealable test port.

Ideally the test port should be at least 450mm away from the air heater flue connection socket. However if a concentric flue fitting is attached directly to the connection sockets then the combustion should be tested through the flue outlet collar via a drilled test port which must be securely plugged on completion.

Follow the flue pipe manufacturers installation instructions for making joints, including connections to the air heater, for passing through a building element and for support requirements.

Gasket sealed single wall flue seamless aluminium or stainless steel pipes are required. All joints must be sealed to prevent products of combustion from leaking into the building. If the flue passes through a combustible element of the building it must be enclosed by a sleeve of non-combustible material and separated from the sleeve by a minimum of 25 mm air break. The temperature of any combustible material near to the flue must not exceed 65°C when the heater is in operation. The flue must be at least 150 mm away from any combustible material.

Flues for power vented installations (type B appliances)

If the air heater is to be installed as a type B appliance, air for combustion will be taken from within the space where the heater is installed. Ensure that an adequate air supply for combustion and ventilation is provided within the building in accordance with BS6230/BS5440 plus other relevant regulations & rules in force.

Figure 2 : Approved appliances type B

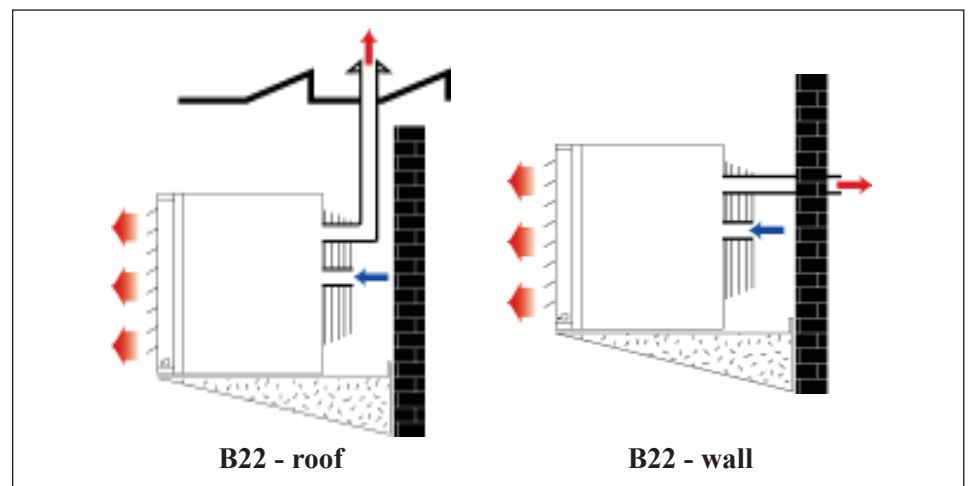
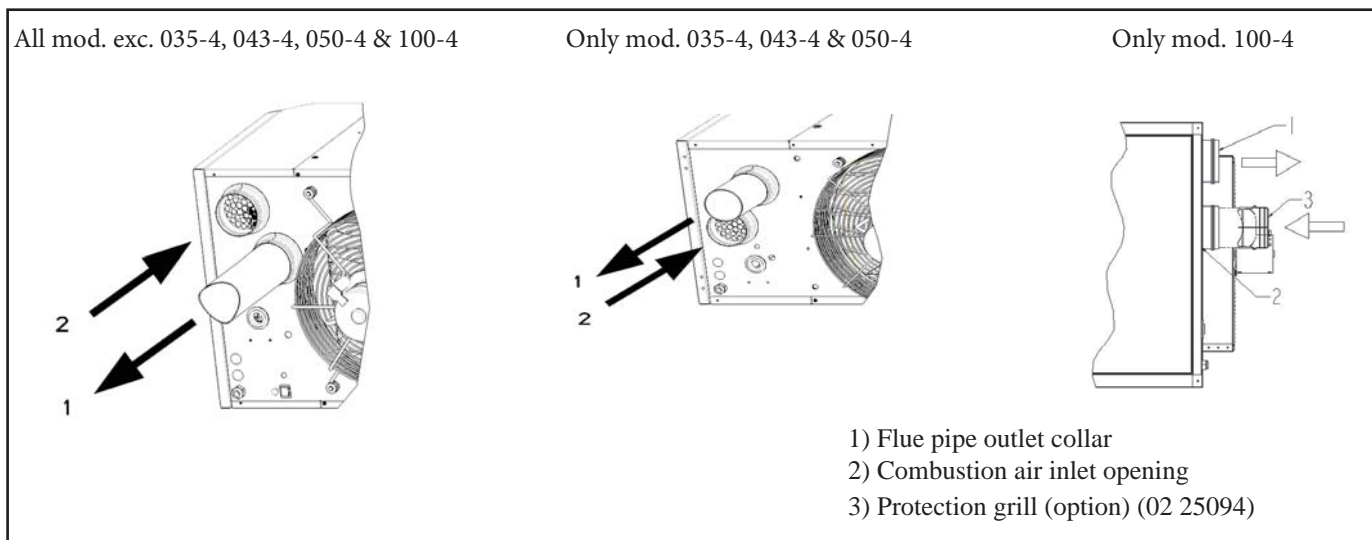

Figure 3 : Type B appliances : Combustion air and flue pipe sockets



Air supply

WARNING :

When these air heaters are installed in type B applications, designed to take air for combustion from the space in which it is installed. Do not restrict the combustion air intake.

It is important to ensure that there is an adequate air supply at all times for both combustion and heating requirements. Modern buildings involve greater use of insulation, improved vapour barriers, and weather proofing. These practices mean that buildings are sealed much tighter than in the past.

Proper combustion air supply for a power vented Type B installation requires ventilation of the heated space. Natural infiltration of air may not be adequate. Use of exhaust fans aggravates this situation. It is important to ensure that there is adequate combustion air supply at all times. Reliance on doors and windows is not allowed.

Always ensure that adequate combustion air is provided to suit the total installation of all combustion equipment in accordance with BS6230 or BS5440 as appropriate.

Ensure that the air combustion inlet opening at the rear side of the unit cannot be obstructed (cfr. fig. 3).

Combustion air inlet pipe & flue pipe for balanced flue installation (type C appliances)

Balanced flue air heaters are designed to be fitted with a combustion air inlet duct that obtains outdoor air and a flue pipe that exhausts flue products to outdoors. Both the flue and combustion air pipes must be sealed.

Type C2 appliances must not be applied !

Figure 4 : Approved appliances type C

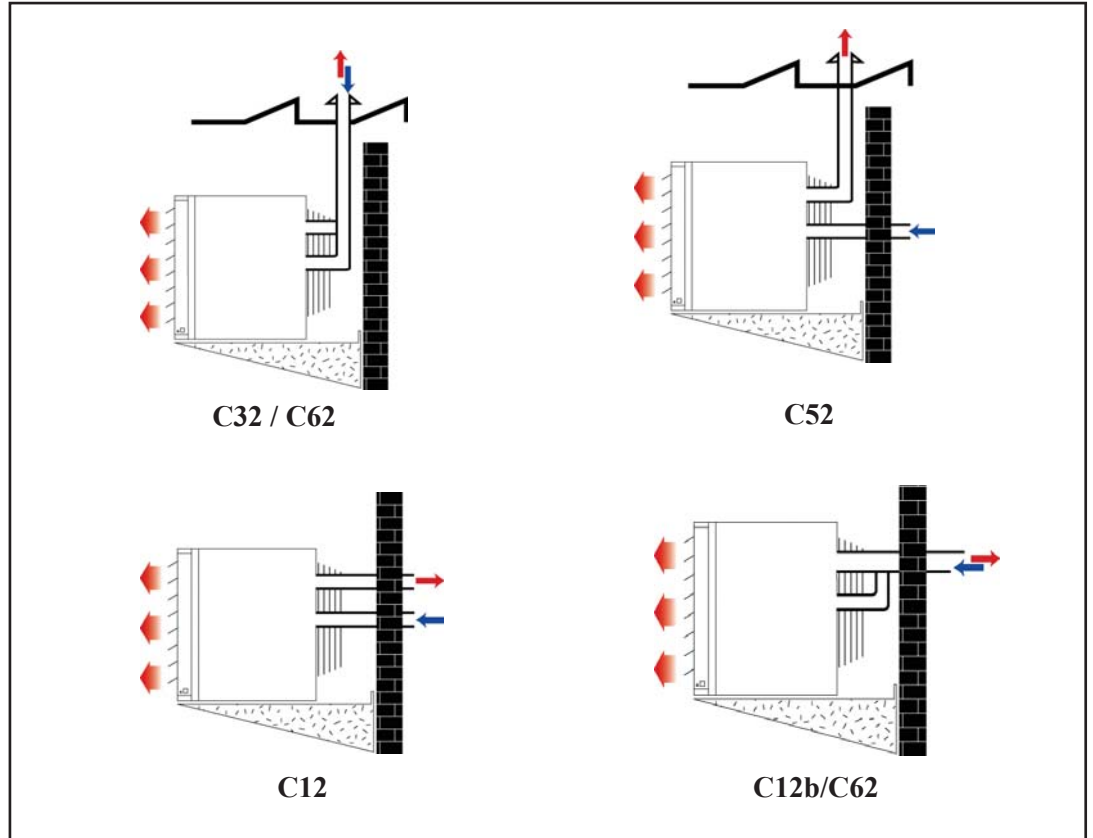
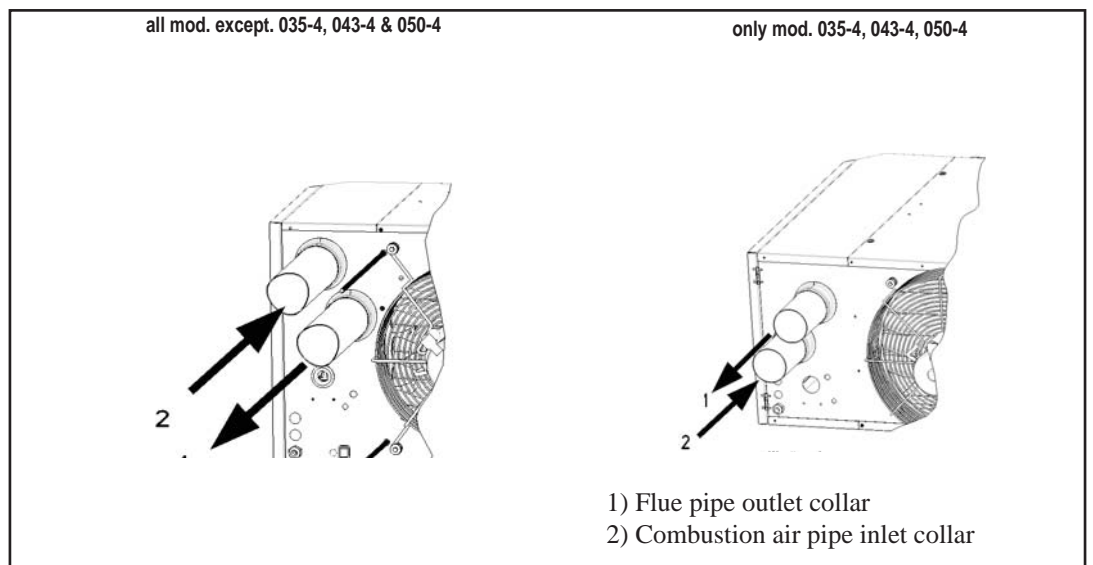

Figure 5 : Type C appliances : Combustion air and flue pipe sockets



8. Location heater

Remark:

Flue requirements may affect location. Consult section 7 before making a final determination.

Use the minimum clearances in section 5 and the throw data in the technical data table of section 6 when determining where to suspend the heater.

Recommended minimum height is 2.5mm.

WARNING: If touched, the vent pipe and internal heater surfaces that are accessible from outside the heater will cause burns. Suspend the heater such that these components cannot be touched.

For best results, the heater should be placed with certain rules in mind. Always ensure that minimum clearances are maintained. Locating a unit heater above the maximum recommended height can result in significant air stratification. When possible, heaters should be arranged to blow toward or along exposed wall surfaces. Suspended heaters are most effective when located as close to the working zone as possible, but care should be exercised to avoid directing the discharged air directly on to room occupants.

Partitions, columns, counters, or other obstructions should be taken into consideration when locating the unit heater so that a minimum quantity of airflow will be deflected by such obstacles.

When units are located in the centre of the space to be heated, the air should be discharged toward the exposed walls. In large areas, units should be located to discharge air along exposed walls with extra units provided to discharge air in toward the centre of the area. For optimum results heaters are best used in conjunction with recirculating air fans suspended at high level.

At those points where infiltration of cold air is excessive, such as at entrance doors and shipping doors, it is desirable to locate the unit so that it will discharge directly toward the source of cold air, typically from a distance of 4.5 to 6.0 meters or install a downflow unit over the door opening.

CAUTION : Do not locate the heater where it may be exposed to water.

Hazards of Chlorine - apply to the location of the combustion air inlet

The presence of chlorine vapours in the combustion air of gas-fired heating equipment presents a potential corrosion hazard. Chlorine, found usually in the form of freon or degreaser compounds when exposed to a flame will precipitate from the compound, and go into solution with any condensation that is present in the heat exchanger or associated parts. The result is hydrochloric acid which readily attacks all metals. Care should be taken to separate these vapours from the combustion process. This may be done by wise location of the unit flue and combustion air terminals with regard to exhausters or prevailing wind directions. Chlorine is heavier than air. Keep this fact in mind when determining installation location of the heater in relation to building exhaust systems.

Where chlorine vapours are prevalent heaters with special grade 316 A1SI stainless steel heat exchangers are recommended.

9. Hanging the heater

WARNING:
Check the supporting structure to verify that it has sufficient load-carrying capacity to support the unit weight. Suspend the heater only from the threaded nut retainers or with a manufacturer provided kit. DO NOT suspend from the heater cabinet panels.

Before suspending the heater, check the supporting structure to verify that it has sufficient load-carrying capacity to support the weight of the unit.

Leave the unit on the pallet. If the bottom of the unit is not supported or protected damage can occur.

Table 6 :

UDSA-4	008	011	015	020	025	030	035
kg	30	33	38	40	54	57	86
UDSA-4	043	050	055	064	073	085	100
kg	99	102	114	118	143	160	179

Warning : Do not place or add additional weight to the suspended heater.

The heater is supplied with four point suspension. All points must be used. Two threaded nut retainers are provided on each side of the top of the heater. See figure 6 for hanger rod size.

Figure 6 : Suspending the heater with rods from the threaded nut retainers

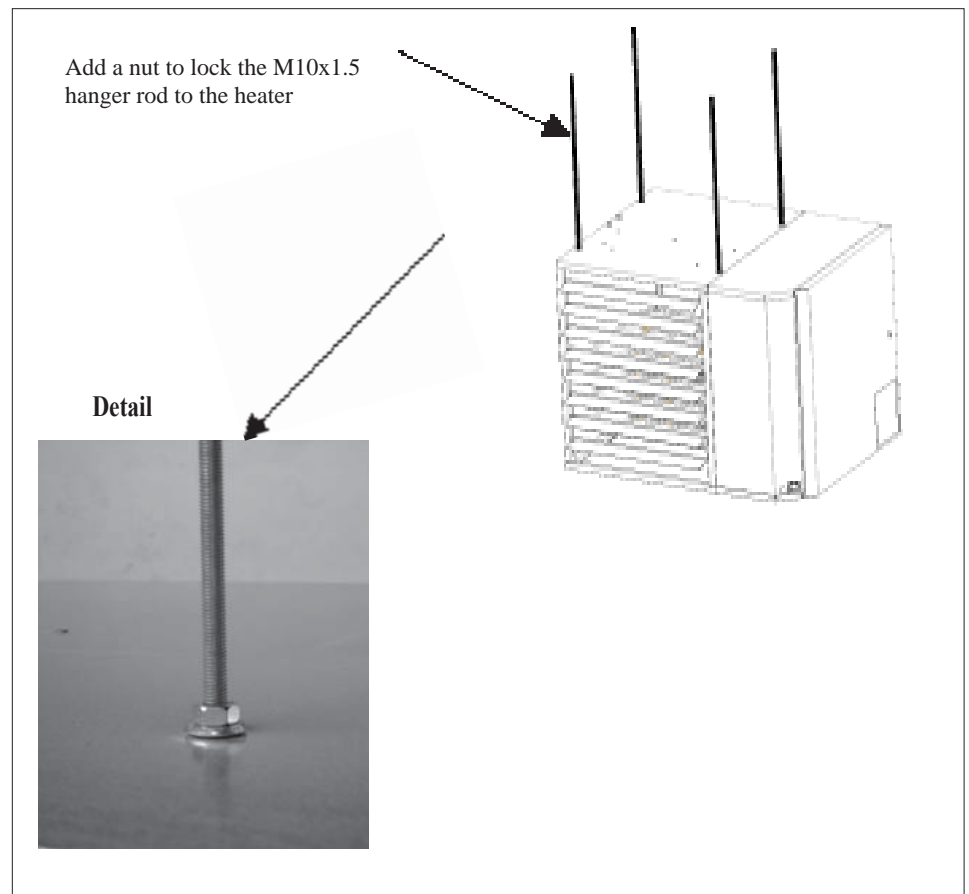

Be sure that the threaded hanger rods are locked to the heater as illustrated in figure 6. Recommended maximum hanger rod length is 1.8m. Where longer drops are required, ensure that restraints are fitted to prevent excess lateral movement and supports are adequately sized.

Figure 7 :
Wall bracket kits (optional)

When desired the heaters may be supported by wall brackets. Supporting in this manner allows the heaters to be placed in close proximity to the ceiling or mounted directly to the vertical supporting structures of the building. There are 2 different wall bracket designs for UDSA-4 models as shown in the illustrations below. Mounting instructions are detailed in the literature supplied with these optional kits

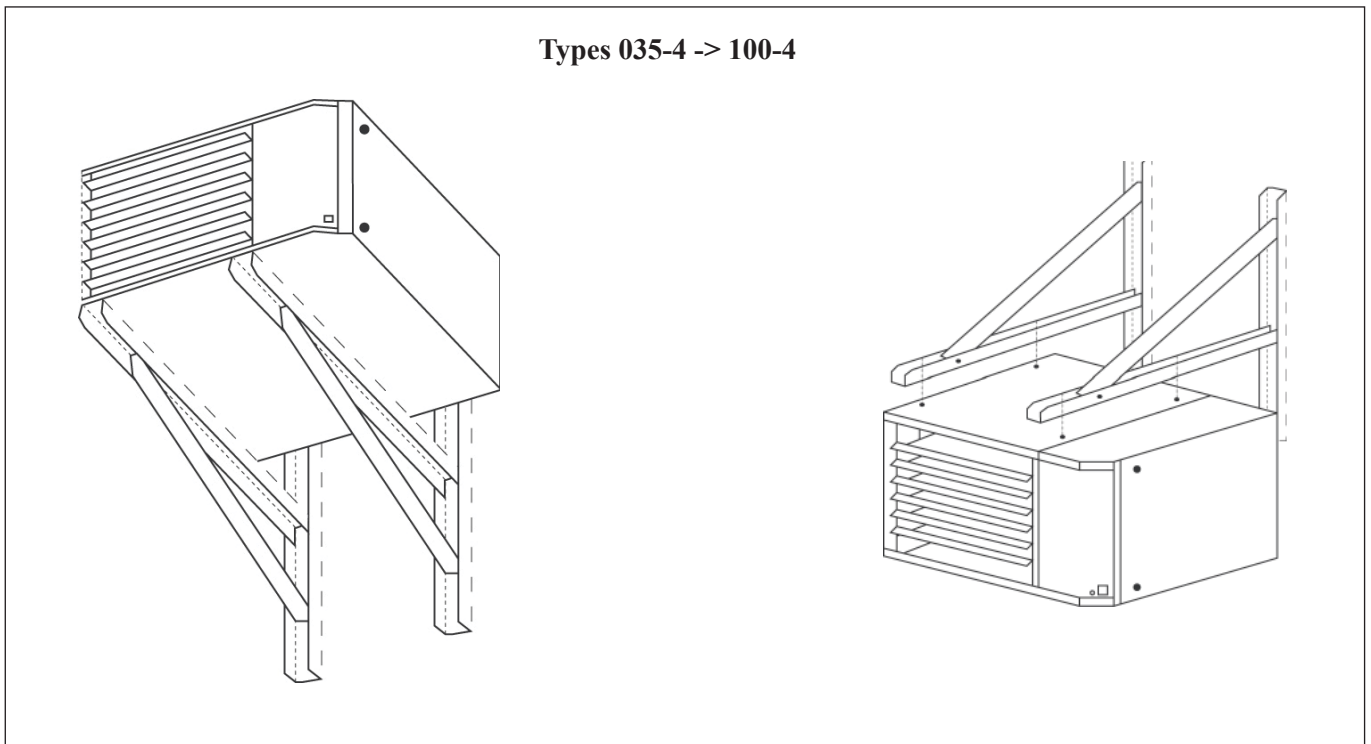
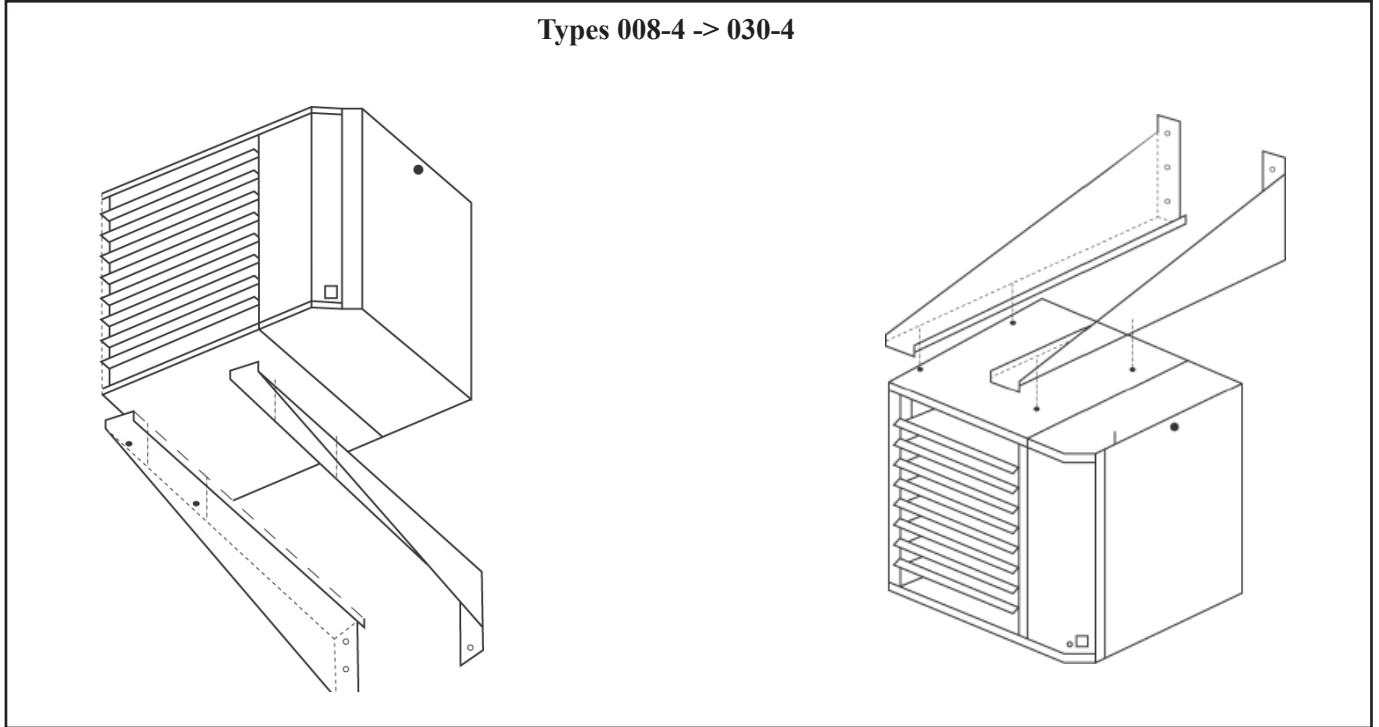

10. Gas Piping and pressures

WARNING: All components of a gas supply system must be leak tested prior to placing equipment in service. NEVER TEST FOR LEAKS WITH AN OPEN FLAME. Failure to comply could result in personal injury, property damage or death.

Warning : This appliance is equipped for a maximum gas supply pressure of 50 mbar.

WARNING : Pressure testing supply piping

Test pressures above 50mbar : Disconnect the heater and manual valve from the gas supply line which is to be tested. Cap or plug the supply line.

Test pressures below 50mbar : Before testing, close the manual valve on the heater.

All piping must be in accordance with requirements outlined in the National Gas Codes (different for each country). Gas supply piping installation should also conform with good practice and any local codes. Support gas piping with pipe hangers, metal strapping, or other suitable material. **Do not rely on the heater to support the gas pipe.**

All sealing products shall be resistant to the action of liquefied petroleum gas or any other chemical constituents of the gas being supplied.

Install a ground joint union and manual shutoff the gas cock upstream of the unit control system.

The unit is equipped with a nipple that extends outside the cabinet. The gas connection is 1/2" or 3/4", dependent on the size of the unit.

Leak test all connections by brushing on a leak detecting solution.

**Diameter gas connection
Table 7 :**

	Nat gas Propane
Model 008-4 through 030-4	1/2"
Model 035-4 through 100-4	3/4"

WARNING :
Do not over tighten and do not rotate the gas valve inside the heater control compartment.

Figure 8 : gas connection

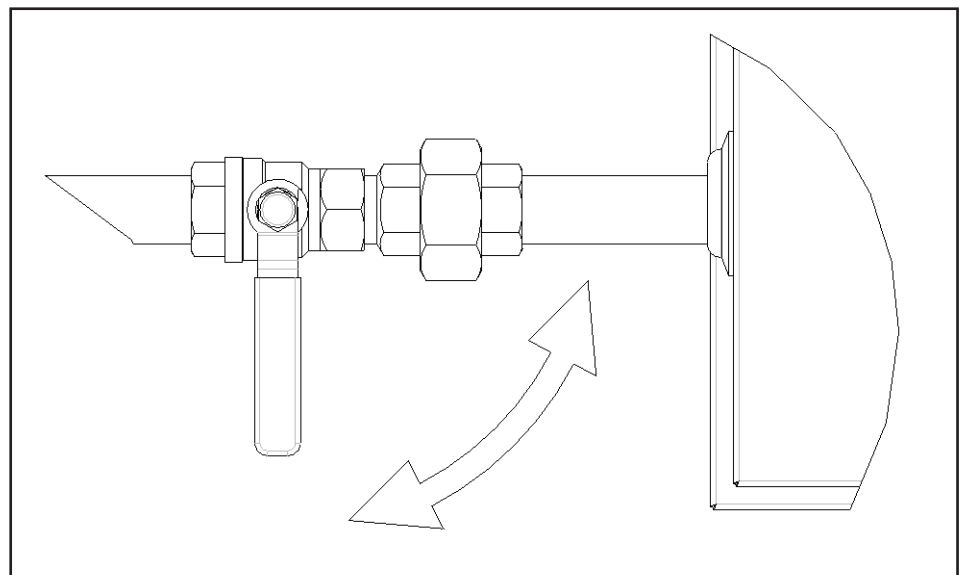

11. Electrical supply and connections

**DANGER :
THIS APPLIANCE
MUST BE
EARTHED.**

The electrical installation may only be carried out by an appropriately qualified person current to IEE Regulations. The supply line to the heater should include a main switch. The minimum **clearance** distance between the contacts must be more than 3 mm.

All electrical connections should be made in the heater control compartment (refer wiring diagram). Screw type terminals are provided. Connections should be in accordance with the terminal markings and the wiring diagram affixed to the air heater.

Attention :

Serious damage can occur to burner relay when faulty connection of thermostat, reset switch or burner failure lamp. Switching of wires for reset switch and flame failure (e.g. in a remote control box) will destroy the burner relay.

The minimum external control required for the air heater is a room thermostat. **It is essential that the main input line and neutral to terminals L and N remain live at all times even when the heater is switched off to ensure correct operation of the unit.**

A burner reset switch with red indicator light is fitted on the heater. To add a remote reset button, make connections to the terminals in the electric box as indicated on the wiring diagram.

IMPORTANT: If the reset button requires activating for any reason, the cause must be determined. After determining and correcting the problem, restart the heater and monitor long enough to ensure proper operation (approx. 5 minutes).

An orange indicator light is fitted on the heater to signify when the burner is on.

Ensure that all cables and installers wiring are fixed to the gas pipe and that they do not touch the combustion collector box.

Thermostat location

Do not attempt to control more than 1 air heater from a single thermostat or control panel unless a properly wired relay is fitted. Follow the instructions supplied with such panels.

The location of the room thermostat or sensor is very important. It should not be positioned on a cold wall or cold surface. Avoid location in draughty areas or where it may be influenced by heat sources e.g. the sun, process plant, etc. The thermostat should be mounted on a vibration free surface and mounted about 1,5 metres above floor level. Follow the thermostat manufacturers instructions. The thermostat must be suitable for potential free contacts.

12. Check installation & start-up

Check the installation prior to start-up

- Check suspension. Unit must be secure. Verify that no other parts are fitted which are not individually supported and secured.
- Check clearances from combustibles. Requirements are in section 5.
- Check vent system to be sure that it is installed according to the instructions in section 7, venting requirements.
- Check piping for leaks and proper gas line pressure. Bleed gas lines of trapped air.
- Check electrical wiring and ensure that wiring conforms with the wiring diagram. Be sure all wire sizes meet requirements.
- Check polarity. Verify that line voltage exists between the black “L1” and earth ground.
- Verify that the appliance is earthed by conducting an earth continuity test.

Heater start-up

WARNING:

For your safety, follow the instructions exactly otherwise damage or injury could occur.

- This heater does not have a pilot flame. It is equipped with an ignition device which automatically lights the burner. Do not try to light the burner by hand.
- Before operating, smell all around the heater area for gas. Be sure to smell next to the floor because propane gas is heavier than air and will settle near the floor.
- Do not use this appliance if any part has subjected to water ingress. Immediately call a qualified service technician to inspect the appliance and to replace any part of the control system and any gas control.
- When overheating occurs or when gas supply is not turned off, shut the manual gas tap before turning off the electric power.

Operating instructions and operating sequence

1. Set thermostat to the lowest setting.
2. Turn off all electric power to the heater.
3. Shut the gas cock at the inlet of the unit.
4. Wait five (5) minutes to clear out any gas. Then smell for gas, including near the floor. If you smell gas, STOP! and follow the steps in the WARNINGS printed on page 3. If you do not smell gas, proceed to the next step.
5. Turn on the electric power to the heater.
6. Open the gas cock at the inlet of the unit.
7. If fitted, ensure that a time switch is set to an 'ON' period.
8. Adjust the thermostat to the required setting (must be above current room temperature).

Note :

If the appliance does not operate, follow the instructions "To turn off gas supply at the Appliance" printed below and call your service technician.

9. Thermostat calls for heat, energizing the venter motor.
10. When adequate air flow for combustion is proven by an air proving switch and a prepurge period has elapsed, the integral ignitor and multifunctional gas control operate. The ignition spark ignites the gas creating the burner flame.
11. Burner flame is sensed by a flame rod sensor and when the heat exchanger is warmed up (+/- 30 seconds) and the fan control relay closes, the fan motor is energized.
12. If the flame is extinguished during the main burner operation, the integrated control system closes the main valve and attempts to relight the burner. The unit will attempt 5 ignitions before entering a "lock out" mode. Lock out is indicated by the red warning light on the heater. To end this mode push on the reset switch.
13. To turn the heater 'OFF' for short periods : adjust the room thermostat to its lowest setting or 'OFF'. The fan will continue to run to cool the heater and then switch off automatically.
14. To turn the heater 'OFF' for long periods : see 'To turn off gas supply at the appliance' below.

Check installation after start-up

TO TURN OFF GAS SUPPLY AT THE APPLIANCE

- 1) Set thermostat to the lowest possible setting or 'OFF' position.
- 2) Shut off the gas tap when the fan has stopped.
- 3) Switch off electric power to the appliance.

- Check gas pressure as described in detail below.
- Turn the unit off and on, pausing 2 minutes between each cycle. Observe for smooth ignition.
- Set the thermostat to the required room temperature.
- Place this booklet and any control or optional information in an accessible location near the heater or give this information to the end user.

Burner gas pressure adjustment

The gas pressure is set for the required heat input before the appliance leaves the factory. Provided that the gas supply to the air heater is in accordance with the supply pressure described on the appliance data plate, the operating pressure will not require adjustment. To check the pressure use the following procedure:

- * Ascertain from the heater's data plate the correct operating gas pressure;
- * Turn the room thermostat control to its lowest setting;
- * Remove the screw from the burner pressure test point of the multi-functional control valve. Connect a manometer to the test point(see figure 10a & 10b);
- * Adjust the room thermostat to call for heat i.e. above room ambient temperature;
- * Observe the burner gas pressure on the manometer and compare to the required pressure on the data plate;
- * If necessary, adjust the burner gas pressure. Remove the cover screw (models 035-2 ->100-2) or cover cap (models 008-2 -> 030-2). Turn the regulator screw anti-clockwise to decrease pressure or clockwise to increase pressure (see figure 10a & 10b);
- * Set room thermostat to lowest setting to turn OFF the burners. Replace the test point screw/cap and with the main burner OFF, test for gas soundness using a leak detector fluid.

Reset temperature control/room thermostat to comfort operating level.

Figure 9 : Honeywell gas valve (types 008-4 -> 043-4)

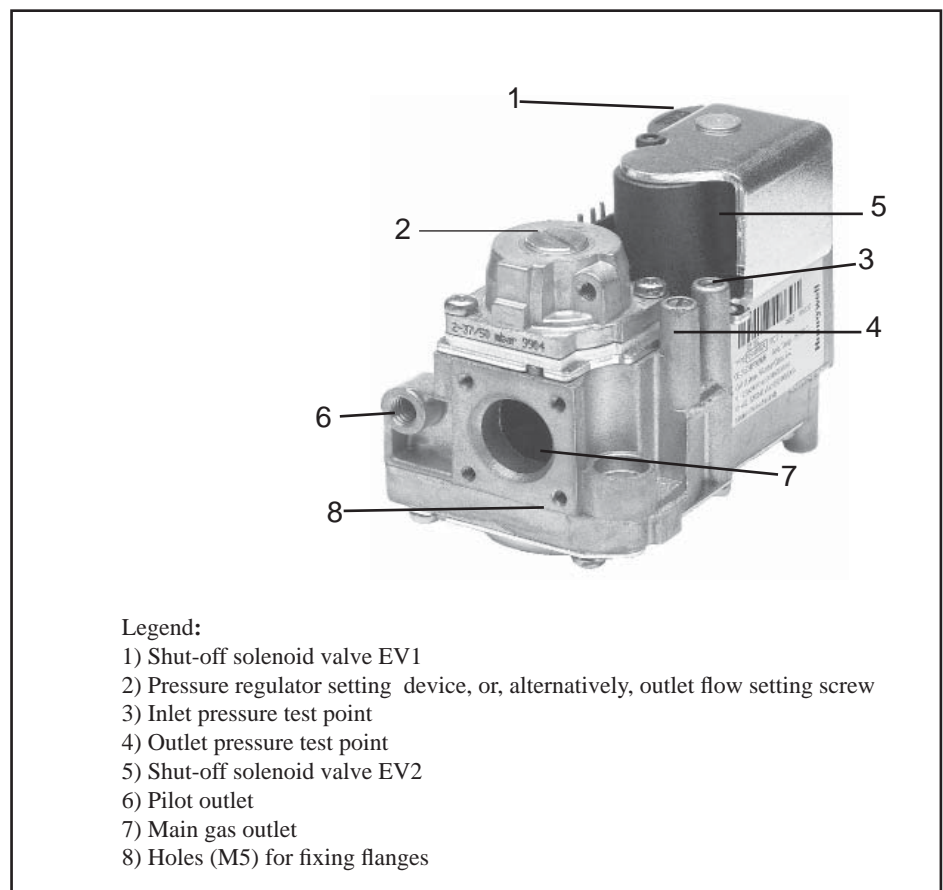

Figure 10 : HONEYWELL gas valve (type 050-4 -> 100-4)

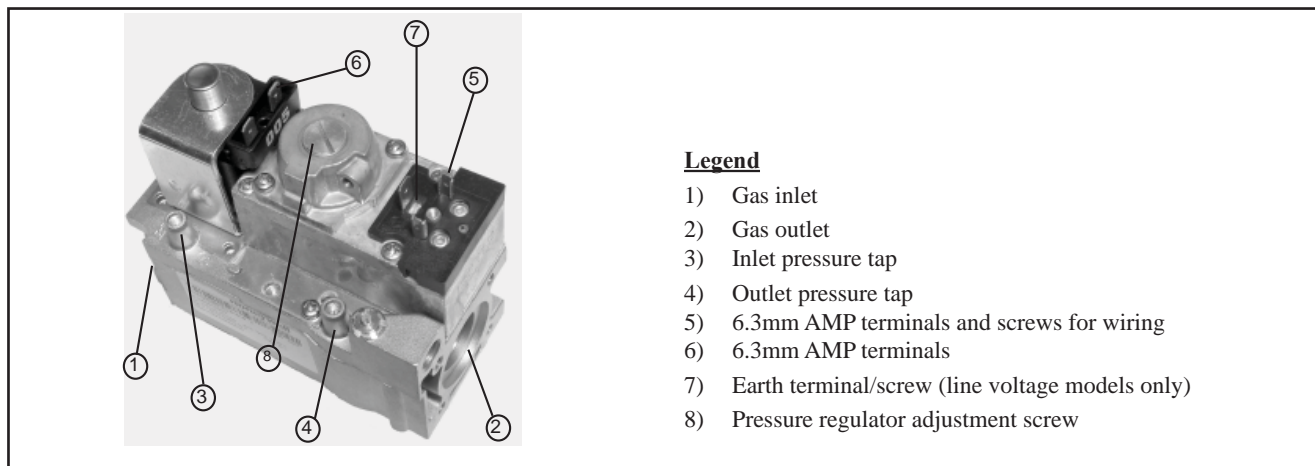

Table 8 : Burner jets and pressures

*Belarus, China, Croatia, Czech Republic, Cyprus, Estonia, Greece, Iceland, Latvia, Lebanon, Lithuania, Montenegro, New Zealand, Portugal, Serbia, Slovenia, Slovakia, Spain, Turkey, Poland

UDSA-4			008	011	015	020	025	030	035	043	050-	055	064	073	085	100	
Nat. Gas (G20)	Burner jet	dia	2,60	3,20	3,70	4,20	4,80	5,30	5,75	6,50	6,80	7,10	8,00	7,40	8,90	10,00	
	Burner pressure	mbar	8,00	7,90	7,80	7,10	8,20	7,50	7,65	7,40	7,90	8,40	7,90	12,00	8,00	7,10	inlet pressure 20 mbar
Nat. Gas (G27)	Burner jet	dia	2,60	3,20	3,70	4,20	4,80	5,30	5,75	6,50	6,80	7,10	8,00	7,40	8,90	10,00	
	Burner pressure	mbar	12,00	11,50	11,20	10,40	12,40	10,80	11,00	10,20	11,60	12,00	11,50	17,10	11,30	10,00	inlet pressure 20 mbar
Prop. (G31)	Burner jet	dia	1,40	1,70	1,95	2,15	2,60	2,80	3,10	3,35	3,70	3,90	4,15	4,50	4,90	5,20	
	Burner pressure	mbar	36,90	36,90	36,90	36,90	36,80	36,80	35,20	34,80	35,80	35,70	35,60	35,10	34,60	34,50	inlet pressure 37 mbar

G27 : only for Poland

*Romania,

UDSA-4			008	011	015	020-	025-	030	035	043	050	055-	064	073	085	100	
Nat. Gas (G20)	Burner jet	dia	2,60	3,20	3,70	4,20	4,80	5,30	5,75	6,50	6,80	7,10	8,00	7,40	8,90	10,00	
	Burner pressure	mbar	8,00	7,90	7,80	7,10	8,20	7,50	7,65	7,40	7,90	8,40	7,90	12,00	8,00	7,10	inlet pressure 20 mbar
Prop. (G31)	Burner jet	dia	1,40	1,80	2,10	2,25	2,80	2,95	3,30	3,60	3,80	4,10	4,40	4,90	5,10	5,60	
	Burner pressure	mbar	29,90	29,90	29,90	29,90	29,80	29,80	27,90	27,90	28,80	28,40	28,50	28,10	27,70	27,50	inlet pressure 30 mbar

*Hungary, Russian Federation, Ukraine

UDSA-4			008	011	015	020-	025-	030	035	043	050	055-	064	073	085	100	
Nat. Gas (G20)	Burner jet	dia	2,60	3,20	3,70	4,20	4,80	5,30	5,75	6,50	6,80	7,10	8,00	7,40	8,90	10,00	
	Burner pressure	mbar	8,00	7,90	7,80	7,10	8,20	7,50	7,65	7,40	7,90	8,40	7,90	12,00	8,00	7,10	inlet pressure 20 mbar (1)
Prop. (G31)	Burner jet	dia	1,40	1,70	1,95	2,15	2,60	2,80	3,10	3,35	3,70	3,90	4,15	4,50	4,90	5,20	
	Burner pressure	mbar	36,90	36,90	36,90	36,90	36,80	36,80	35,20	34,80	35,80	35,70	35,60	35,10	34,60	34,50	inlet pressure 50 mbar

(1): Hungary: inlet pressure = 25 mbar

*Bulgaria, Denmark, Finland, Norway, Sweden

UDSA-4			008	011	015	020-	025-	030	035	043	050	055-	064	073	085	100	
Nat. Gas (G20)	Burner jet	dia	2,60	3,20	3,70	4,20	4,80	5,30	5,75	6,50	6,80	7,10	8,00	7,40	8,90	10,00	
	Burner pressure	mbar	8,00	7,90	7,80	7,10	8,20	7,50	7,65	7,40	7,90	8,40	7,90	12,00	8,00	7,10	inlet pressure 20 mbar
Prop. (G31)	Burner jet	dia	1,40	1,70	1,95	2,15	2,60	2,80	3,10	3,35	3,70	3,90	4,15	4,50	4,90	5,20	
	Burner pressure	mbar	28,90	28,90	28,90	28,90	28,80	28,80	28,54	28,22	29,00	28,90	28,90	28,50	28,10	27,97	inlet pressure 30 mbar

Ignition system

Normal Heat Cycle Operating Sequence

This heater is equipped with a direct spark integrated control relay. The control relay monitors the safety devices and controls the operation of the venter motor and the gas valve between heat cycles.

The time line below illustrates a normal heat cycle.

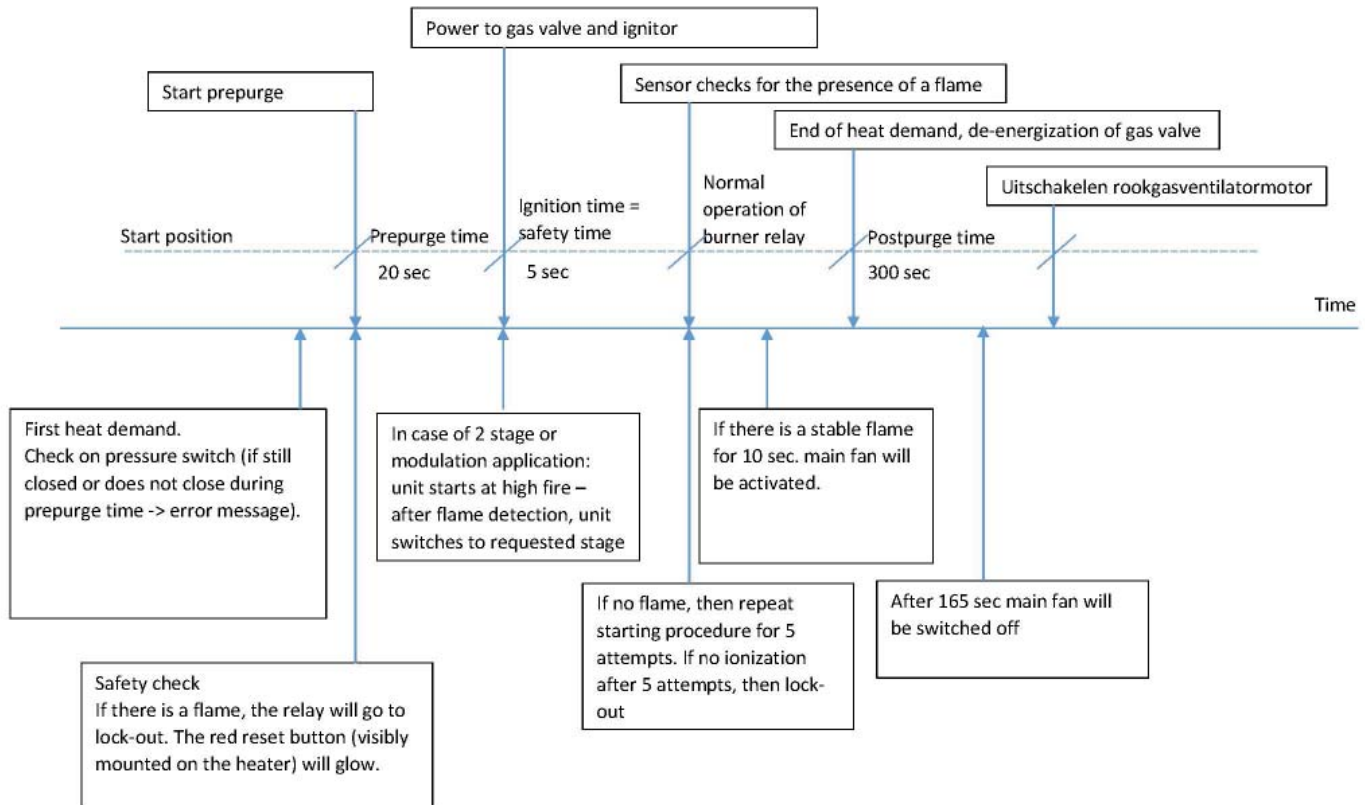

Definitions

- Start position:** The system is not in lock-out position and can proceed with the start-up sequence upon a demand for heat.
- Pre-purge time:** This is a period of 20 seconds during which the combustion fan (venter) operates prior to activation of the ignition device.
- Safety time:** The safety time is the delay between the gas valve being energised and the flame sensor checking for the presence of a flame. This is a period of 5 seconds.
Note: If no flame is sensed, the burner relay will **attempt ignition 5 times before going into lock-out mode.**
- Post-purge time:** This is the time of 5min. between burner shut-down and the moment the combustion fan (venter) is de-energized.

13. Maintenance & Service

Warning :

If you turn off the power supply, always turn off the gas.

The material contained in the MAINTENANCE AND SERVICE Section of this manual is designed to aid a qualified service technician in maintaining and servicing this equipment. This heater will operate with a minimum of maintenance. To ensure long life and satisfactory performance, a heater that is operated under normal conditions should be inspected and cleaned at the start of each heating season (inspection and maintenance at least once a year). If the heater is operating in an area where an unusual amount of dust or other impurities are present in the air, more frequent maintenance is recommended.

When any service is completed, be careful to reassemble correctly to ensure that no unsafe conditions are created. When starting the heater, always follow the lighting instructions on the heater.

Maintenance Schedule

Maintenance Schedule - The following procedures should be carried out at least once each year (See figure 11a) :

- Clean all dirt, lint, and grease from the fan blade, fan guard, and motor.
- Check the heat exchanger both internally and externally for evidence of physical damage.
- Check the burner for scale, dust, or lint accumulation. Clean if required.
- Check the vent or vent/combustion air system for soundness. Replace any parts that do not appear sound.
- Check the wiring for any damage. Replace damaged wiring.

NOTE: If replacement parts are required, use only factory-authorized parts.

Figure 11a-Location of controls

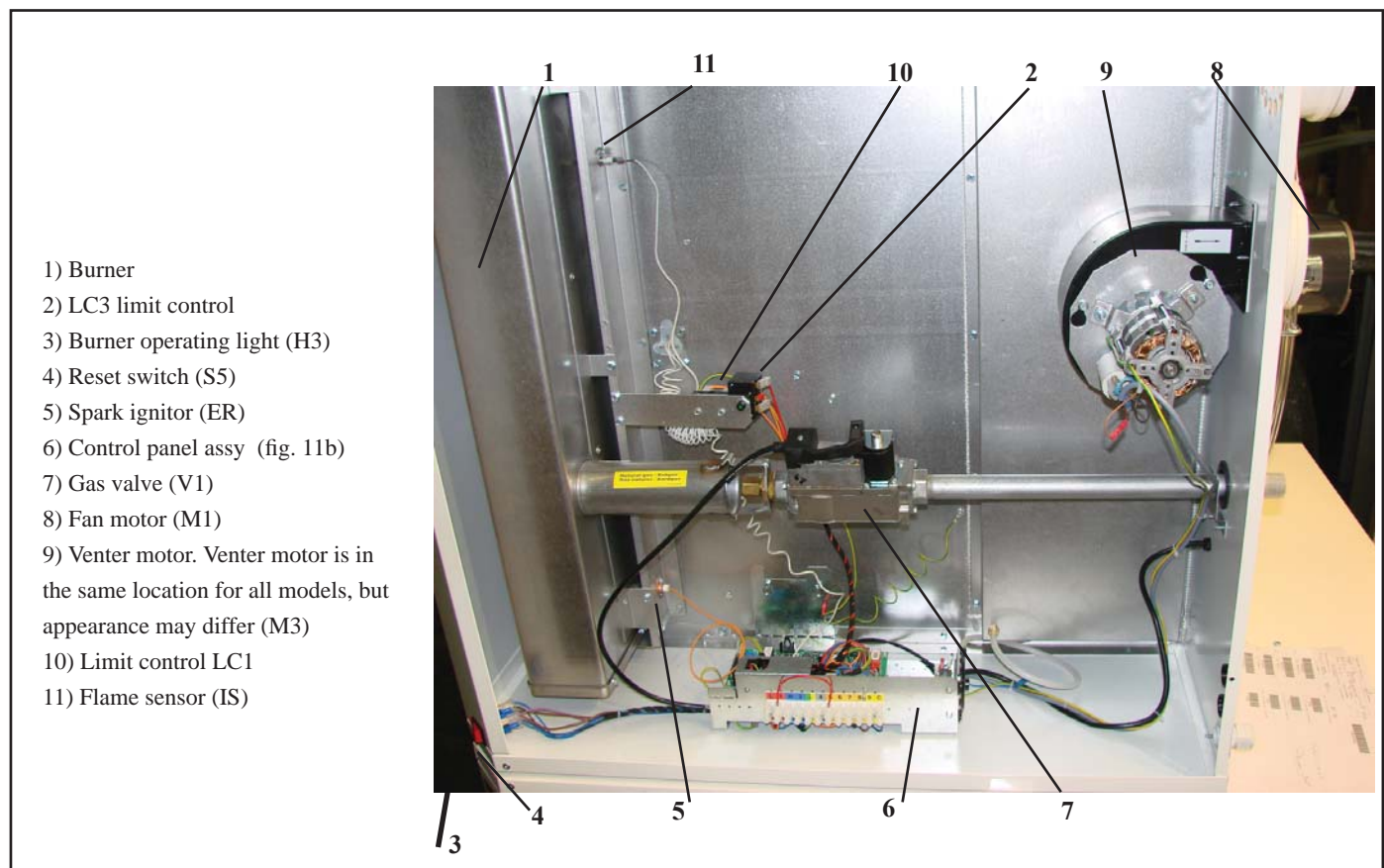
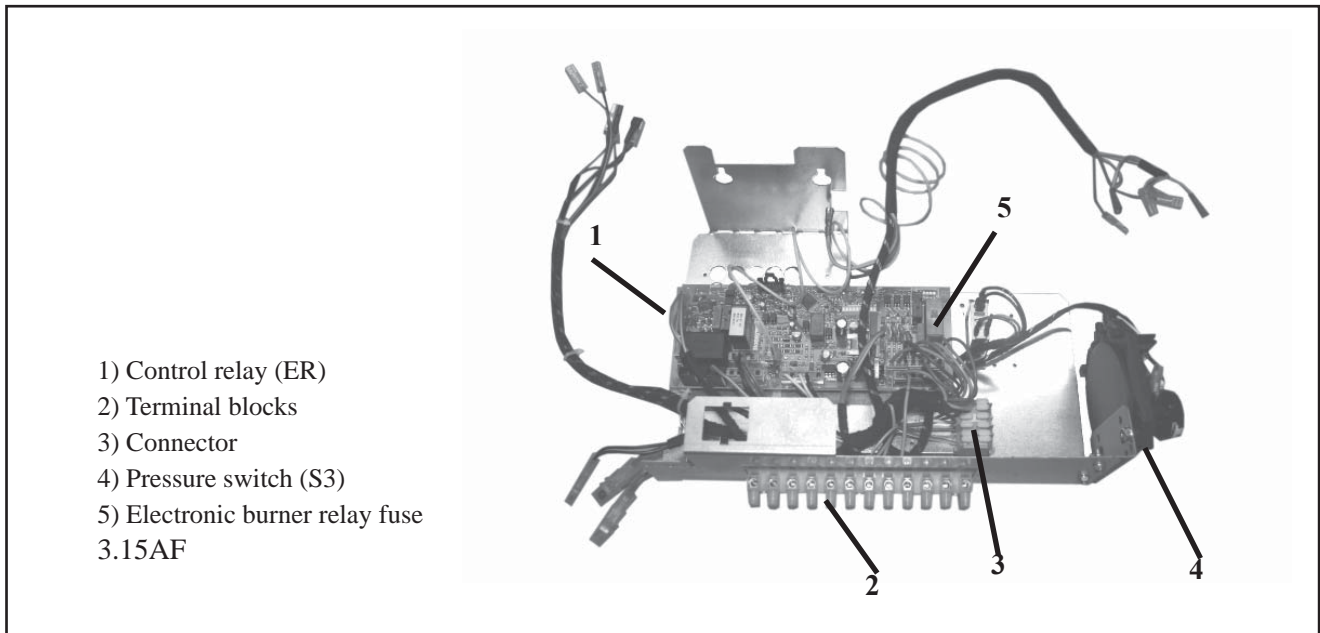

Figure 11b - Control panel assy located on a removable bracket



14. Heat exchanger Maintenance

This heater is equipped with a patented T-CORE²® heat exchanger. Remove any external dirt or dust accumulation. Visually check the heat exchanger for cracks and holes. If a crack or hole is observed, replace the heat exchanger.

15. Burner Maintenance

This heater has a unique one-piece T-CORE²® burner assembly designed to provide controlled flame stability without lifting or flashback. The burner can be removed as a unit for inspection or service : see below for removal instructions.

Inspect the burner/control compartment annually to determine if cleaning is necessary. If there is an accumulation of dirt, dust, and/or lint, clean the compartment and follow the instructions below to remove and clean the burner.

Caution : use of eye protection is recommended.

Burner removal

Instructions for burner removal

1. Outside the cabinet, shut the gas supply off at the manual valve ahead of the union
2. Turn off the electric supply.
3. Disconnect the gas supply at the union outside of the cabinet.
4. Open the access door.
5. **Disconnect the manifold and move it out of the way.** At the gas valve, mark and disconnect the connector. Carefully remove the burner orifice and orifice adapter locking nut. Slide the orifice adapter out through the bracket on the burner pushing the manifold to the right. This will move the manifold out of the way. Refer to figure 14 for component definitions.

Figure 12a



Figure 12b

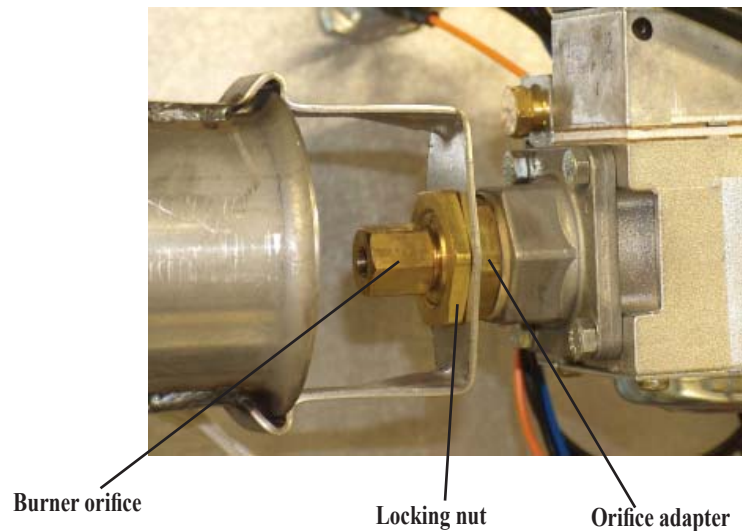

6. Remove burner

- a) Locate the burner body front support. Remove the screws that attach it to the secondary air shield. Refer to fig. 14 for component definitions.

- b) Holding the venturi tube, slide the entire burner slightly to the right to disengage the burner from the supports on the left. Then rotate the open end of the venturi tube outward away from the heater. Carefully pull the burner assembly out of the cabinet.

Figure 13a



Figure 13b



Figure 14 - Burner removal steps

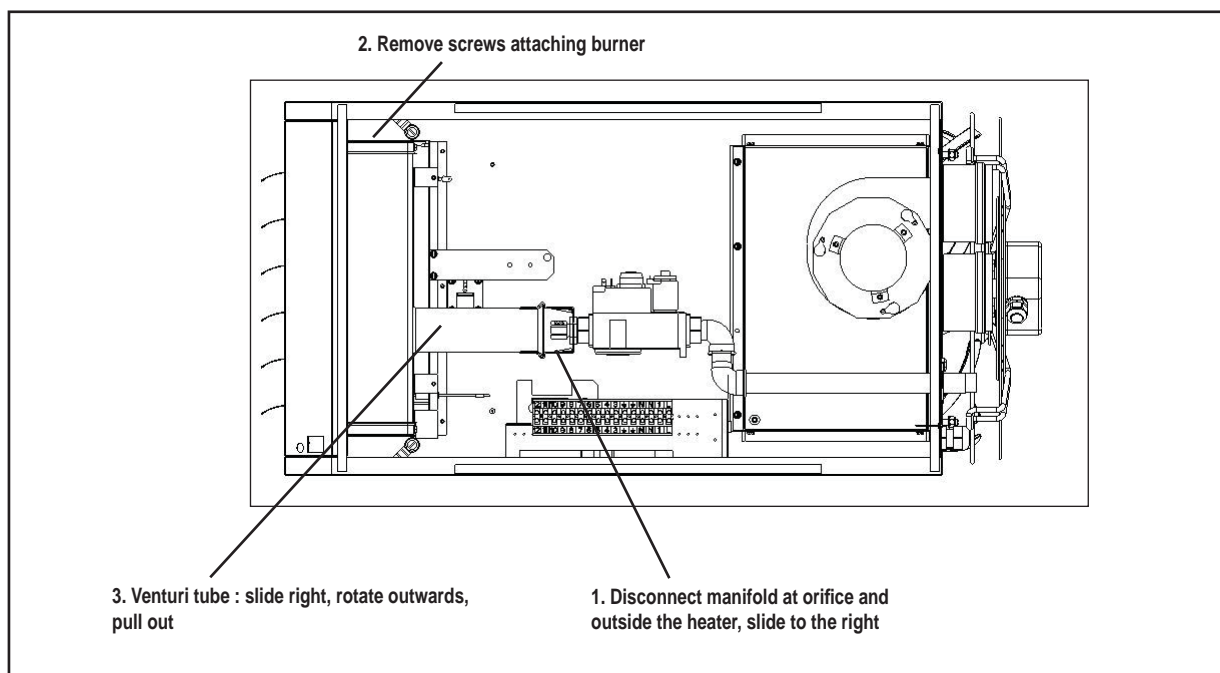

Inspect and clean the burner

With the burner assembly removed, shine a flashlight on the burner ribbons. Look for carbon buildup, scale, dust, lint, and/or anything that might restrict flow through the spaces between the burner ribbons. Holding the burner assembly so that any foreign material will fall away from the burner, use a stiff bristle brush to loosen

Figure 15

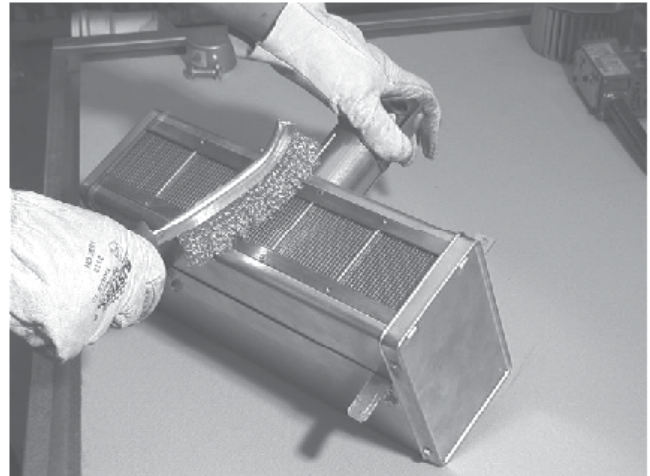

and remove any foreign material(s). If the burner is excessively dirty, remove one of the burner end caps. Remove the four screws that hold the end cap to the burner housing. Lightly tap the end cap to remove it.

Clean all foreign material from the burner and venturi. After the burner is thoroughly clean, replace the end cap making certain that it is tight against the burner housing. NOTE: If any of the burner components are damaged or deteriorated, replace the burner assembly.

Inspect the Internal Portion of the Heat Exchanger (with burner assembly removed)

At the burner flame entrance of each tube, shine a bright light into each heat exchanger section. With the light shining into the heat exchanger, observe the outside surface of the tube where discoloration is evident. Repeat this procedure with each heat exchanger tube. If any light is observed in these high temperature regions, replace the heat exchanger.

Reinstall the burner

Repeat 'Burner removal' steps above in the opposite order.

16. Burner orifice

The burner orifice normally needs to be replaced only when a change in gas is made. When ordering a replacement orifice, provide (MJ/m³) heating value and specific gravity of gas, as well as the model and serial number of the unit. When removing or replacing the burner orifice be careful not to damage the venturi tube and/or the bracket.

17. Ignition system

Ignitor - Refer to figure 11a and locate the ignitor. Disconnect the wire; remove the screw and the ignitor. Clean the ignitor assembly with an emery cloth.

Spark gap must be maintained to 3 mm. See FIGURE 16a.

Important : When reassembling, the wire must remain attached to the ignitor.

Figure 16a
Ignitor showing required
spark gap measurement

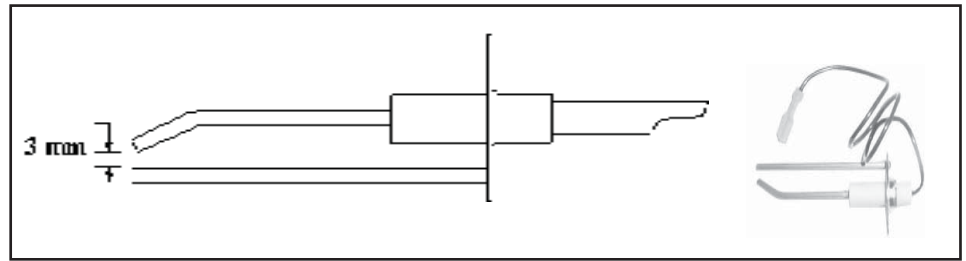
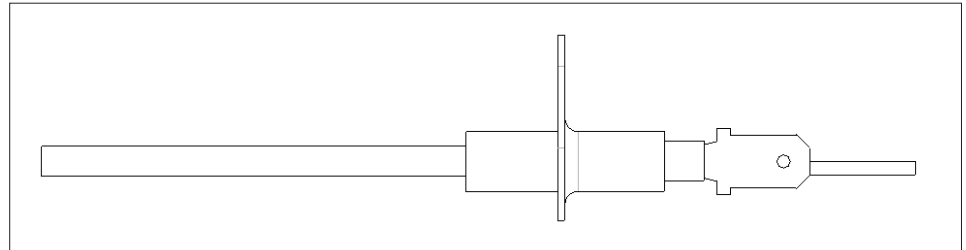

Figure 16b
Flame sensor



Caution : Due to high voltage on the spark wire and electrode, do **not** touch when energized.

Flame sensor - Refer to figure 11a and locate the flame sensor. Disconnect the wire, remove the screw and the flame sensor. Clean with an emery cloth..

Control relay - See figure 17. The electronic burner relay monitors the operation of the heater including ignition. Do not open the control relay. Each heating season check the lead wires for insulation deterioration and good connections.

Proper operation of the direct spark ignition system requires a minimum flame signal of 1.0 microamps (DC) as measured by a microammeter.

For further information and check out procedure on the direct spark ignition system, refer to section 12 and the Troubleshooting Flow Chart in section 25.

Figure 17 - Control relay
(type BMBC Honeywell)



18. Fan motors

The fan motor is equipped with thermal overload protection of the automatic reset type. Should the motor fail to run, it may be because of improper voltage characteristics. Make certain that the correct voltage is available at the motor.

Remove dirt and grease from the motor, the fan guard, and blades. Use care when cleaning the fan blades to prevent causing misalignment or imbalance. Check that the hub of the fan blades is secure to the shaft.

Follow these instructions for replacement of the fan guard, fan motor and/or fan blades.

1. If the heater is installed, turn off the gas and disconnect the electric power.
2. Open the access door and disconnect the fan motor wires.

3. Remove the fan assembly (fan guard, motor and fan blade).
4. Disassemble and replace parts as needed, then reassemble.
Be sure the fan blade is in the proper position on the shaft; refer to the illustration and table in table below for types 008, 011, 015 & 020.
Position the assembly on the heater and attach the fan guard.
Rotate the fan blade by hand to check for adequate clearance. If adjustment is required, loosen the mounting screws, reposition the fan guard, and tighten the screws. Rotate the fan blade and recheck for adequate clearance. Repeat this procedure until the assembly is positioned properly.
5. Reconnect the fan motor wires according to the wiring diagram and close the access door.
6. Restore power to the heater and turn on the gas. Light, following the instructions on the lighting instruction plate. Check for proper operation.

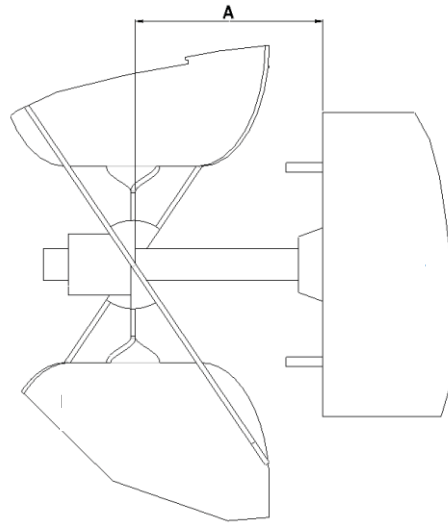

Dimension A

Type	008	011	015	020
mm	29	23	50	49

19. Venter motor & wheel

Remove dirt and grease from the motor casing, the venter housing, and the venter wheel. Venter motor bearings are permanently lubricated.

Follow these instructions for replacement of the venter motor and wheel assembly. Keep all hardware removed to be used in reassembling and installing the replacement parts.

1. Turn off the gas and disconnect the electric power.
2. Open the control compartment access door.
3. Disconnect the three venter motor wires at the control relay and ground screw (located on the control panel).
4. Holding the motor, remove the screws that attach the motor plate to the venter housing. Remove the motor and wheel assembly from the heater.
5. Reassemble with the replacement venter motor and wheel assembly.
6. Follow the wiring diagram to properly connect the wires.
7. Restore power to the heater and turn on the gas. Light, following the instructions on the lighting instruction plate. Check for proper operation. Replace the access door.

Venter wheel position on shaft

UDSA models 008-4 - 020-4

(Rotation clockwise from motor shaft end)

Figure 18a

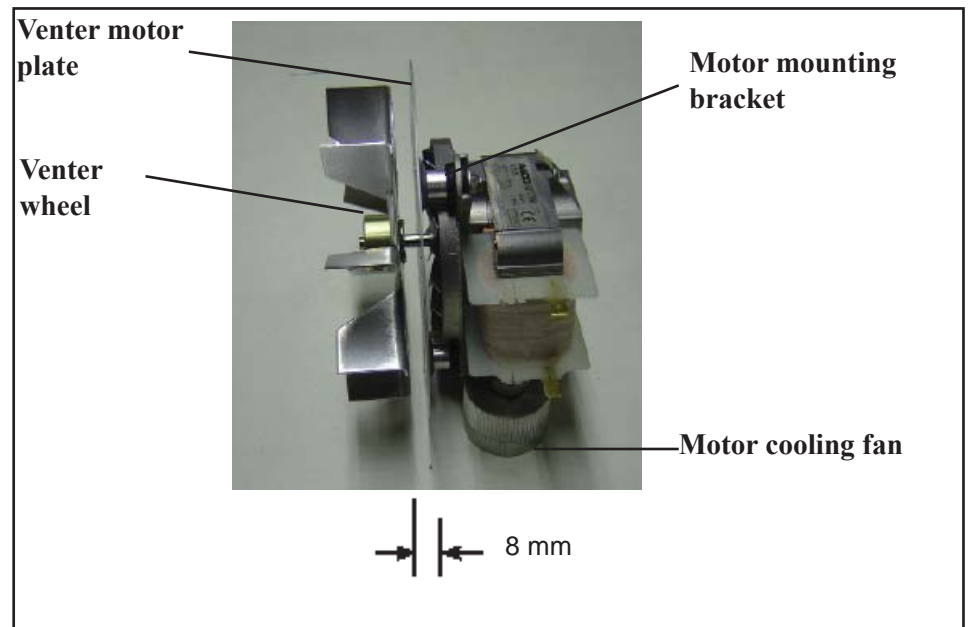

UDSA models 025-4 - 030-4

(Rotation clockwise from motor shaft end)

Figure 18b

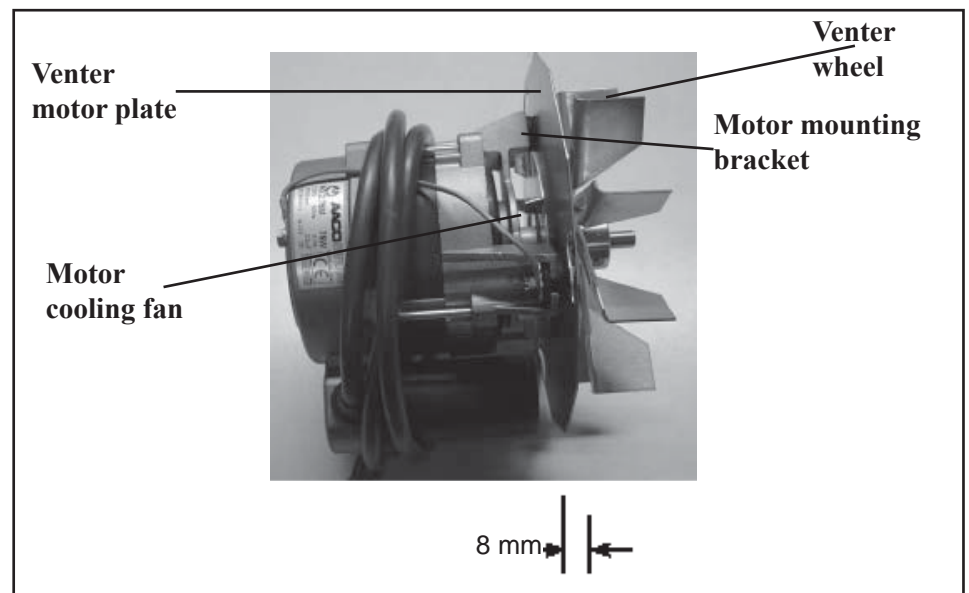

UDSA models 035-4 - 100-4

(Rotation counter clockwise from motor shaft end)

Figure 18c

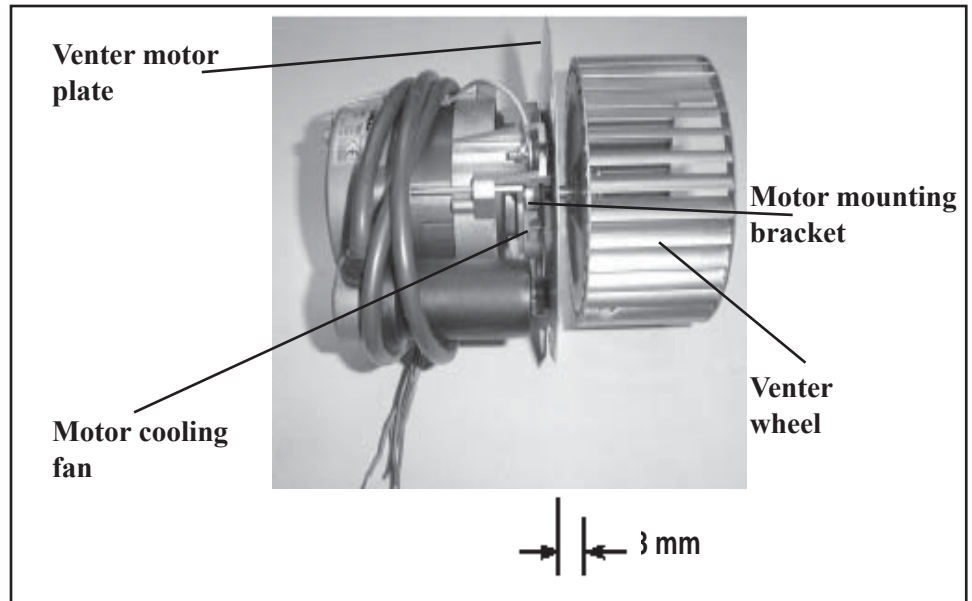

20. Operating gas valve

The main operating quick opening gas valve is powered through the thermostat and safety controls. The main control valve is of the diaphragm type providing regulated gas flow and is preset at the factory. The gas valve requires no field maintenance except careful removal of external dirt accumulation and checking of wiring connections. Instructions for testing pressure settings are in section 12.

WARNING: The operating valve is the prime safety shutoff. All gas supply lines must be free of dirt or scale before connecting to the unit to ensure correct sealing.

21. Combustion air pressure switch

The combustion air pressure switch ensures that proper combustion airflow is available. The switch senses the differential pressure between the negative pressure in the flue gas collector box and the pressure in the control section.

On startup when the heater is cold, the sensing pressure is at the most negative level, and as the heater and flue system warm up, the sensing pressure becomes less negative.

If a restriction or excessive flue pipe length causes the sensing pressure to be below the allowable level, the pressure switch will shut off the main burner.

DANGER : Safe operation of this unit requires proper venting flow. Never bypass the combustion air pressure switch or attempt to operate the unit without the venter operating.

Figure 19



See figure 10, for location. If it is determined that the pressure switch needs replacing, use only the factory-authorized replacement part that is designed for the model and size of heater being serviced.

22. Limit controls

All units are equipped with temperature activated limit controls. The controls are factory set and non-adjustable. If either setpoint is reached, the corresponding limit control will interrupt the electric power to the gas valve. These safety devices provide protection in the case of motor failure or lack of airflow due to restrictions. (For locations, see figure 11a.)

If a limit control needs replacing, use only the factory authorized replacement part for the size of heater.

For approximate limit locations, see figure 11a.

Figure 20 : LC1

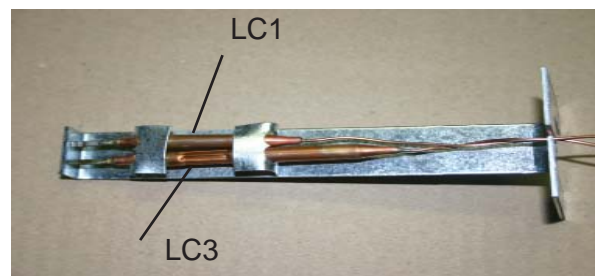

Figure 21 : LC3



Warning :
Never bypass the limit controls, hazardous conditions could result.

Figure 22 : Location LC1/LC3



23. Flue and combustion air piping

Check the complete system at least once a year. Inspection should include all joints, seams, concentric adapters and the flue terminal cap. Replace any defective or heavily corroded parts.

24. Trouble-shooting

The integrated control relay monitors the operation of the heater. If the heater fails to operate properly, review the flow chart below and see the operating sequence in section 16.

The general troubleshooting charts on the following pages will also help you to determine the problem.

Control relay

Troubleshooting flowchart

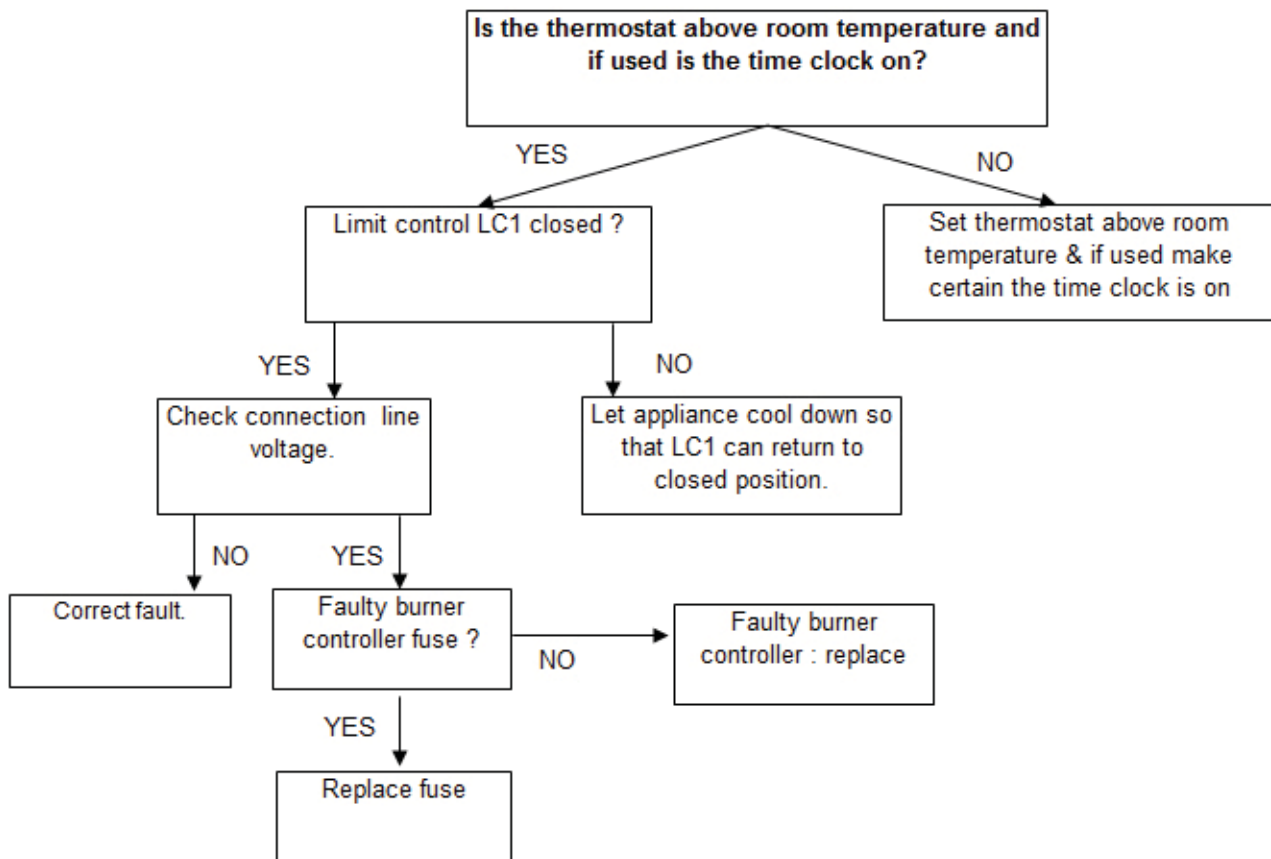

2/ Air heater does not operate and lock-out indicator light is on

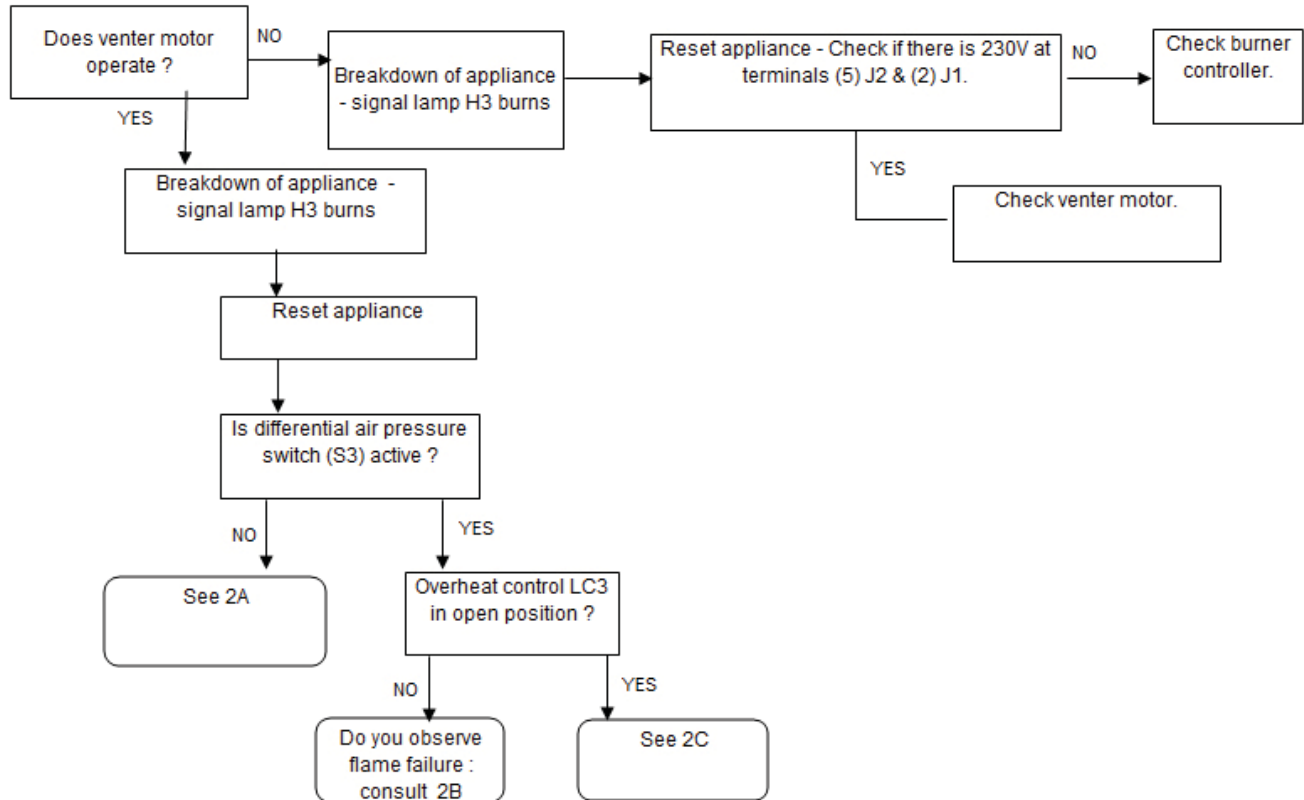

2A :Faulty differential air pressure switch

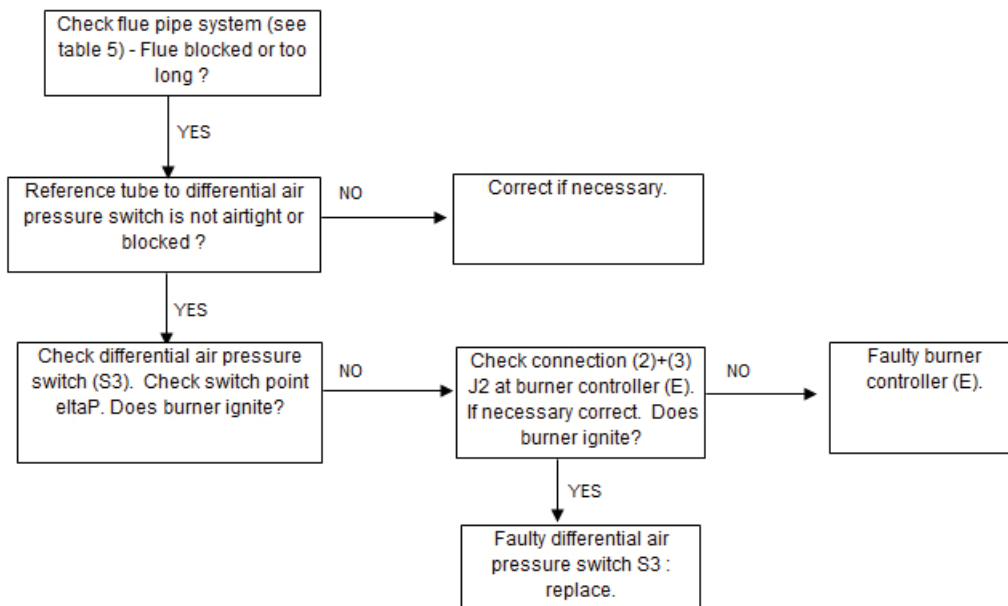

2B : Flame failure

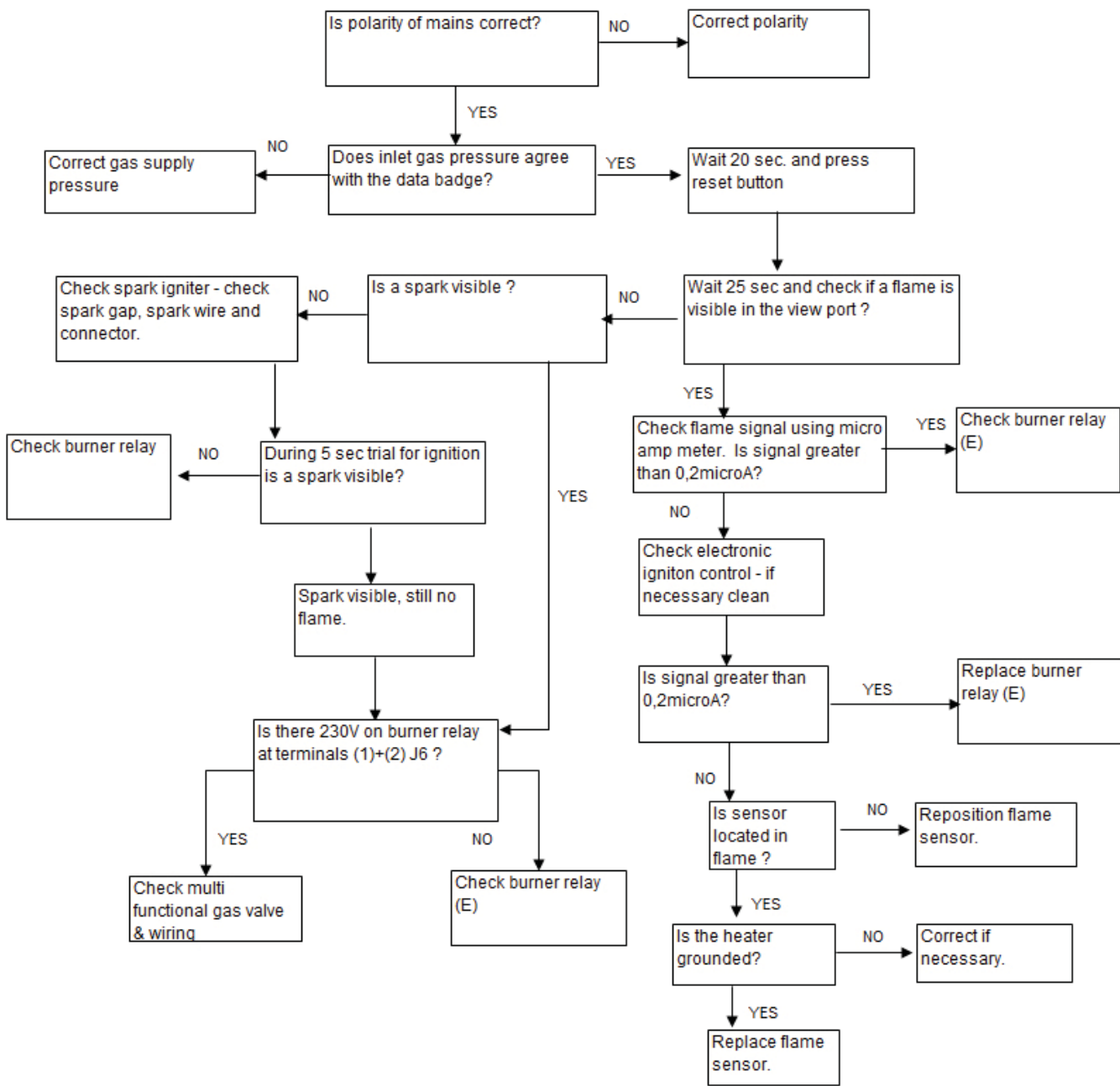

2C : Limit controls LC1 (auto reset) & LC3 (manual reset) switch burner off

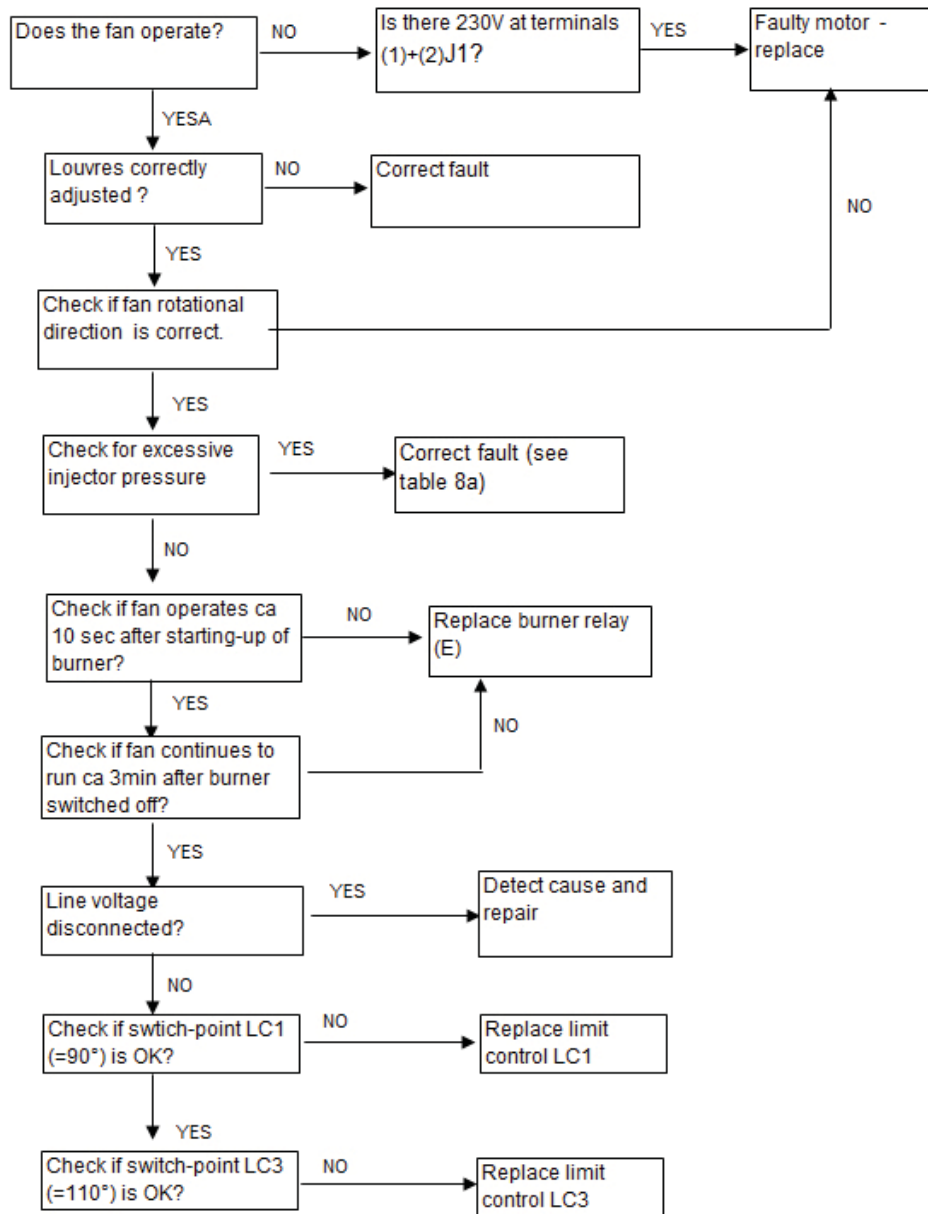

3/ Air fan does not operate

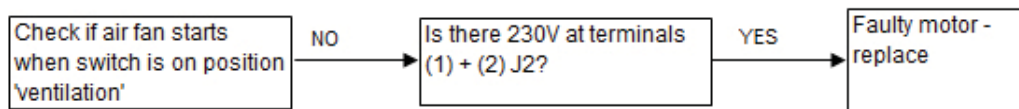

General Troubleshooting

PROBLEM	PROBABLE CAUSE	REMEDY
Venter motor will not start	<ol style="list-style-type: none"> 1. No power to unit 2. No power to venter motor 3. Integrated burner relay defective. 4. Defective venter motor. 5. Fluse blown (F3.1). 6. Fuse burner relay blown. 7. LC1 open. 8. LC3 open. 9. Unit in lock-out. 10. Room thermostat open. 	<ol style="list-style-type: none"> 1. Turn on power, check supply fuses or circuit breaker. 2. Check connections at burner relay and/or venter motor terminals. 3. Replace burner relay. 4. Replace venter motor. See Section 26. 5. Replace fuse. 6. Replace fuse. 7. a) Set heater on ventilation until LC1 closes. b) Replace LC1. c) Check if there is obstruction at the fan side. 8. a) Reset LC3. b) Replace LC3. 9. Push on reset button. 10. Set thermostat above room temperature.
Burner will not light	<ol style="list-style-type: none"> 1. Main valve not operating 2. Air in the gas line. 3. Gas pressure too high or too low. 4. No spark: <ol style="list-style-type: none"> a) Loose wire connections. b) Incorrect spark gap. c) Spark cable has a short circuit to ground. d) Spark electrode has a short circuit to ground. e) Burner relay not grounded. f) Unit not properly grounded. g) Faulty burner relay. 5. Combustion air pressure switch not closing upon power to venter and reset lamp is burning. 	<ol style="list-style-type: none"> 1. a) Check voltage on valve during ignition period. b) Check connector on main gas valve. c) Check connector on burner relay. d) Replace valve. 2. Purge gas line. 3. a) Supply pressure should be 15 mbar for natural gas (UK only) or 37 mbar for propane gas (UK only). b) Obstruction in the gas line. c) Gas line connection diameter too small. 4. Check the following: <ol style="list-style-type: none"> a) Be certain all wire connections are solid. b) Maintain spark gap at 3 mm. c) Replace worn or grounded spark cable. d) Replace if ceramic spark electrode is cracked or grounded. e) Check burner relay ground wire. f) Make certain unit is properly field grounded (earthed) and properly phased (L1 to hot lead, L2 to neutral). g) If voltage is available to the burner relay and all other causes have been eliminated, replace burner relay. 5. First check the following: <ol style="list-style-type: none"> a) Make sure unit is properly vented. b) Remove obstructions from vent. c) Replace faulty tubing to pressure switch. d) Replace faulty pressure switch.
Burner cycle on and off	<ol style="list-style-type: none"> 1. Gas pressure too high or too low. 2. Burner relay not grounded. 3. Faulty burner relay. 4. Flame sensor grounded. 5. Cracked ceramic at sensor. 6. Incorrect polarity. 	<ol style="list-style-type: none"> 1. Supply pressure should be 15 mbar for natural gas (UK only) or 37 mbar for propane gas (UK only). 2. Check burner relay ground wire connection. 3. If (220/240) volts is available to the burner relay and all other causes have been eliminated, replace burner relay. 4. Be certain flame sensor lead is not grounded or insulation or ceramic is not cracked. Replace as required. 5. Replace sensor. 6. Check polarity switch and if necessary reverse line voltage wires to terminal block connections.
Blower or venter motor turns on and off while burner is operating	<ol style="list-style-type: none"> 1. Motor internal thermal protection device cycling on and off. 	<ol style="list-style-type: none"> 1. Check motor load against motor rating plate. Replace motor if needed.

25. Parts list

Description	UDSA-4	Part number
Control relay	all	03 25324
Spark ignitor	all	05 25162
Flame sensor	all	03 401US 195292
Limit control LC3	all	03 24959 03
Limit control LC1	all	03 24959 04
Pressure switch	030'	30 60621 100
Pressure switch	035'	30 60621 94
Pressure switch	043'	30 60621 94
Pressure switch	073'	30 60621 130
Pressure switch	all exc .030,035,043,073	30 60621 120
Burner on indication lamp	all	60 61996
Reset switch	all	60 61988
Gas valve nat gas 1 stage	008...043	03 25141
Gas valve nat gas 1 stage	050....100	03 25136
gas valve prop 1 stage	008...043	03 25141
gas valve prop 1 stage	050....100	03 25136 B (ALL excp. HU,UA,RU)
gas valve prop 1 stage	050....100	03 35137 01(HU,UA,RU)
gas valve nat gas 2 stage	008...100	03 25136 02
gas valve prop 2 stage	008...100	03 35136 P437
Gas valve nat gas modureg	008...100	03 35145
Gas valve prop modureg	008...100	03 35136 M337
Gas valve plug + wire	008..043	03 25141 V1
Gas valve plug + wire	050...100	03 25136 V1
Venter motor	008...020	11 43430 01
Venter motor	035...100	11 43426 04
Venter assembly	008...020	35 25218
Venter assembly	025...030	35 25222
Venter assembly	035....100	35 25223
Venter wheel	008....020	90 82242
Venter wheel assy	025...030	90 82244
Venter wheel	035...100	02 25728
fan motor	008...011	01 25630
fan motor	015...020	01 25631
axial fan	.008	02 25701
axial fan	.011	02 25701 01
axial fan	.015	02 25702
axial fan	.020	02 25702 01
ERP fan	.025	01 27005
ERP fan	.030	01 27006
ERP fan	.035	01 27007 01
ERP fan	.043	01 27007 01
ERP fan	.050	01 27009 01
ERP fan	.055	01 27011 01
ERP fan	.064	01 27011 01
ERP fan	.073	01 26063
ERP fan	.085	01 26063
ERP fan	.100	01 27014 01
Main wiring assy 1st	all	06 41800
Main wiring assy 2st	all	06 41801

CERTIFICATE

**EC DECLARATION OF CONFORMITY OF MACHINERY
(Annex II 1 A of EC Machinery Directive 2006/42/EC)**

**Nortek Global HVAC Belgium nv
J&M Sabbestraat 130/A000
B-8930 Menen, Belgium**

Hereby declares that the following gas-fired unit heaters:

UDSA-4

Types 008, 011, 015, 020, 025, 030, 035, 043, 050, 055, 064, 073, 085, 100

Complies with the requirements of the above mentioned machinery directive

Complies with the requirements of further directives, namely

GAD 2009/142/EC - EMC 2004/108/EC – LVD 2006/95/EC

the following harmonized standards have been applied:

EN 1020: Non-domestic gas-fired forced convection air heaters for space heating not exceeding a net heat input of 300 kW, incorporating a fan to assist transportation of combustion air and/or combustion products.

The following notified body

Technigas

Chaussée de Vilvorde 156

BE 1120 Brussels

Has been involved with regarding to the

EC type examination number E0677/5331

Menen, 01.07.2016



J. Dubus

Engineering Team Leader

Nortek Global HVAC Belgium NV
J&M Sabbestraat 130/A000
B-8930 Menen

+32(0)56 52 95 11
www.reznor.eu

