

GAS FIRED BALANCED FLUE / FAN ASSISTED FLUE UNIT HEATER WITH CENTRIFUGAL FAN

UDSBD-4E



INSTALLATION - COMMISSIONING - SERVICING



These appliances meet the following EC Directives

DIR 2009/142/EC:GAD

DIR 2014/30/EU:EMC

DIR 2014/35/EU: LVD

DIR 2006/42/EC:MD

Applies to

Belarus, Bulgaria, China, Czech Republic, Croatia, Cyprus, Denmark, Estonia, Finland, Greece, Hungary, Iceland, Latvia, Lithuania, Montenegro, New Zealand, Norway, Poland, Portugal, Romania, Russian Federation, Serbia, Slovakia, Slovenia, Spain, Sweden, Turkey, Ukraine

Please read this document carefully before commencing installation, commissioning and/or servicing.
Leave it with the user or attached to the appliance or gas service meter after installation.

WARNING

Improper installation, adjustment, alteration, service or maintenance can cause property damage, injury or death. All work must be carried out by appropriately qualified persons.

The manufacturer does not take any responsibility in the event of non-observance of the regulations concerning the connection of the apparatus causing a dangerous operation possibly resulting in damage to the apparatus and/or environment in which the unit is installed.

INDEX

Warnings	2
1. General	2
2. Installation codes	2
3. Warranty	2
4. Uncrating and preparation	2
5. Dimensions	3
6. Technical data	6
7. Flueing requirements	10
8. Unit heater location	13
9. Hanging the unit	14
10. Gas piping and pressures	14
11. Electrical supply and connections	15
12. Check installation and start up	17
13. Maintenance schedule	20
14. Heat exchanger maintenance	21
15. Burner maintenance	22
16. Burner orifice	23
17. Ignition system	23
18. Blower motor	24
19. Centrifugal fan	24
20. Gas valve	25
21. Combustion air pressure switch	26
22. Flue and combustion air system	26
23. Limit controls	26
24. Troubleshooting	27
25. Parts list	33



WARNINGS

Improper installation, adjustment, alteration, service, or maintenance can cause property damage, injury, or death. Read the installation, operation, and maintenance instructions thoroughly before installing or servicing this equipment.

Gas-fired appliances are not designed for use in hazardous atmospheres containing flammable vapors or combustible dust, in atmospheres containing chlorinated or halogenated hydrocarbons or in applications with airborne silicone substances.

Should overheating occur, or the gas supply fail to shut off, shut off the manual gas valve to the appliance before shutting off the electrical supply.

Do not use this appliance if any part has been immersed in water. Immediately call a qualified service technician to inspect the appliance and replace any gas control that has been immersed in water.

This appliance is not intended for use by persons (including children) with reduced sensory or mental capabilities or lack of experience and knowledge, unless they have been given supervision or instruction concerning use of the appliance by a person responsible for their safety. Children should be supervised to ensure that they do not play with the appliance.

FOR YOUR SAFETY

What to do if you smell gas

- Do not try to light any appliance.
- Do not touch any electrical switch; do not use any phone in your building.
- Immediately call your gas supplier.
- Evacuate all personnel.
- Do not store or use petrol or other flammable vapours and liquids in the vicinity of this or any other appliance.

1 GENERAL

Models UDSBD-4E are design certified to the CE EN1020 standard for use in industrial and commercial installations only. All models and sizes are available for use with either natural or propane gas. The type of gas, the input rate and the electrical supply requirement is shown on the heater rating plate. Check the rating plate to determine if the heater is appropriate for the intended installation.

This installation manual is shipped with the heater. Verify that the literature is correct for the heater being installed. If the manual is incorrect for the heater, contact the supplier before beginning installation.

The instructions in this manual apply only to the models listed.

Installation should be done by a suitably qualified installer in accordance with these instructions. The installer is responsible for the safe installation of the heater.

2 INSTALLATION CODES

These units must be installed in accordance with BS6230 or BS5440 as appropriate plus all local building codes.

3 WARRANTY

Warranty is void if :

- Wiring is not in accordance with the diagram furnished with the heater.
- The unit is installed without proper clearances as soon as clearances are required regardless of the material being combustible.
- A fan model is connected to a duct system or if the air delivery system is modified.

4 UNCRATING/PREPARATION

This unit was test operated and inspected at the factory prior to crating and was in proper operating condition. If the heater has incurred damage in shipment, document the damage with the transport company and contact your supplier.

Check the rating plate for the gas and electrical specifications of the heater to be sure that they are compatible with the gas and electric supplies at the installation site.

Read this booklet and become familiar with the installation requirements of your heater. If you do not have knowledge of local requirements, check with the gas supplier and any other local agencies who might have requirements concerning this installation.

Before beginning, make preparations for necessary supplies, tools, and manpower. **If the installation includes optional vertical louvers or downturn nozzle etc., install these options before the heater is suspended. Follow the instructions included in the option package.**

5 DIMENSIONS/CLEARANCES (horizontal orientation=standard)

Figure 1a : UDSBD015-4E → UDSBD020-4E

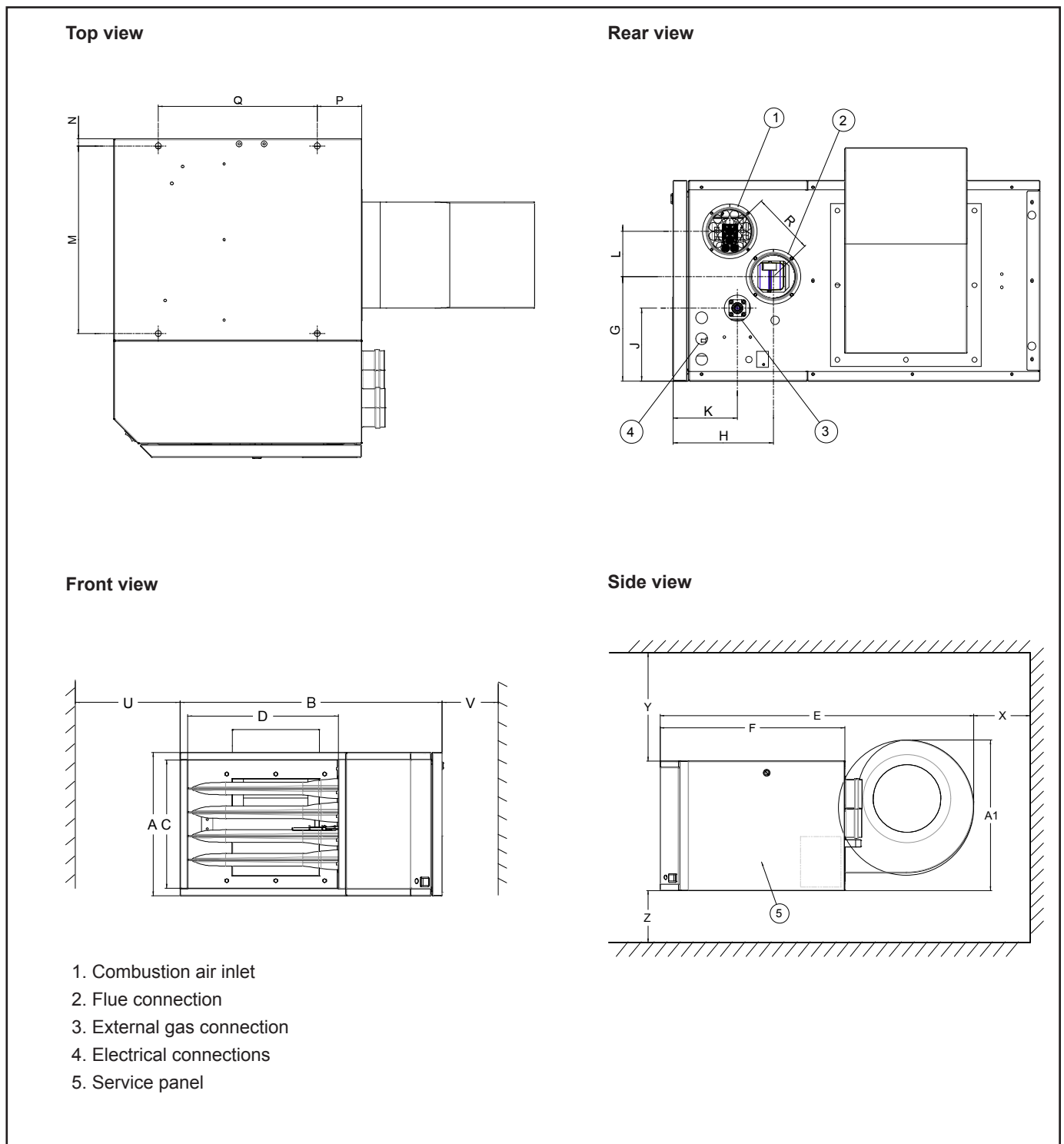

Table 1a : Dimensions (mm)

UDSBD-4E	A	A1	B	C	D	E	F	G	H	J	K	L	M	N	P	Q	R
015	383	460	700	343	404	935	546	199,5	191	139	122	86	413	15,5	98	350	120
020	383	460	700	343	404	935	546	199,5	191	139	122	86	413	15,5	98	350	120

Figure 1b : UDSBD025-4E, 030-4E, 035-4E, 043-4E, 050-4E, 055-4E & 064-4E

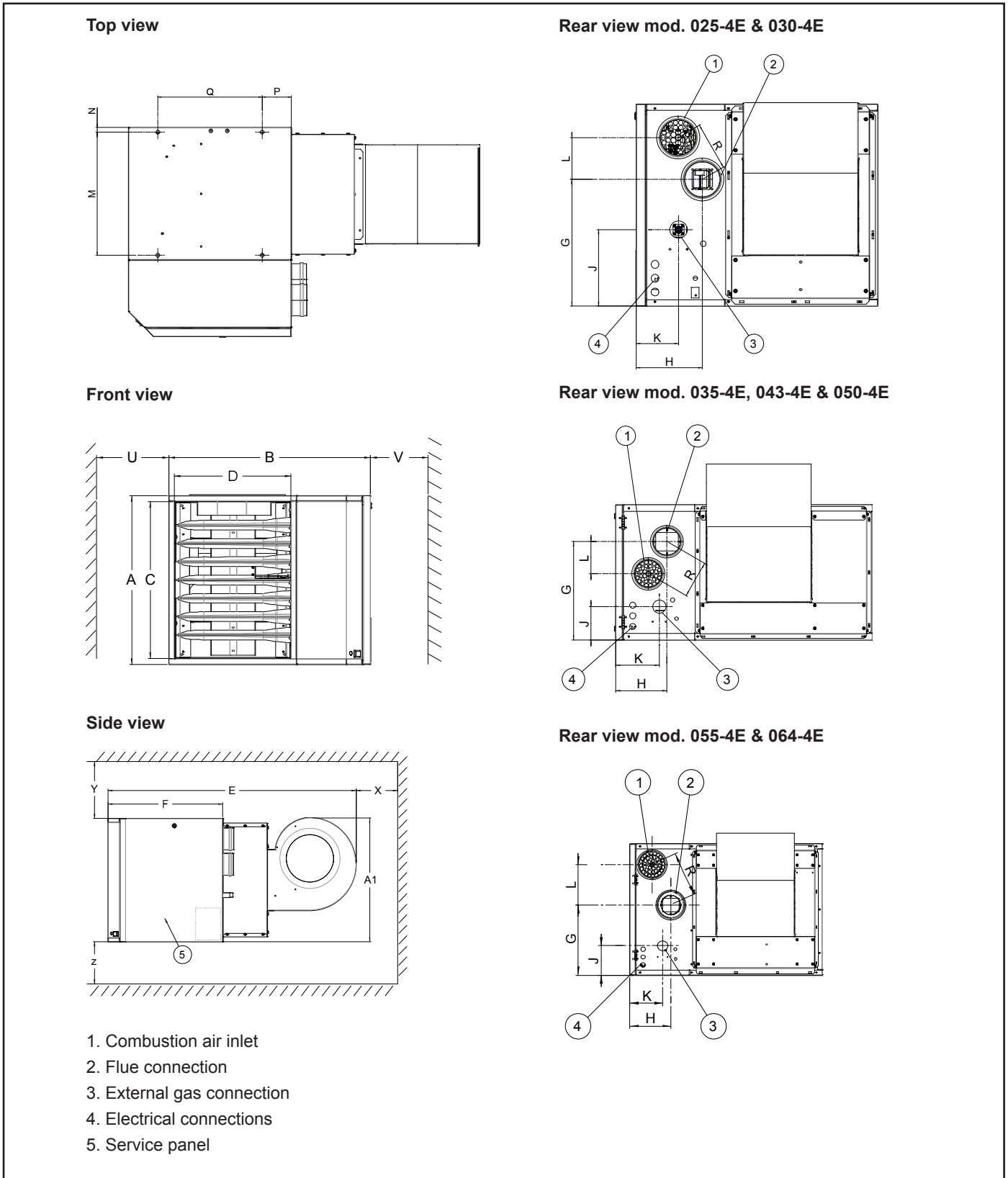

Table 1b : Dimensions (mm)

UDSBD-4E	A	A1	B	C	D	E	F	G	H	J	K	L	M	N	P	Q	R
025→030	586	590	700	546	404	1185	546	367,5	191	222	122	121	413	15,5	98	350	140
035→050	510	670	970	456	601	1610	897	371	194	126	165	121	623	33	148,5	600	140
055	663	685	970	609	601	1610	897	354	206	150	165	204	623	33	148,5	600	225
064	663	720	970	609	601	1610	897	354	206	150	165	204	623	33	148,5	600	225

Clearances (mm)

Units must be installed so that the minimum clearances in the following table are provided for combustion air space, inspection and service and for proper spacing from combustible materials.

Attention :

The clearance distance from the flue system must be minimum 150mm at all points !

Table 2 : Clearances (mm)

UDSBD-4E	X	Y	Z (*)	U	V
015 → 030	100	130	50	270	850
035 → 064	100	180	100	350	850

(*) : Heaters can be base mounted on suitable non combustible supports.

Combustion air supply and flue system diameters Diameter gas connection

Table 3 :

UDSBD-4E	015	020	025	030	035	043	050	055	064
Dia flue/air inlet (mm)	80	80	100	100	100	100	100	130	130
Dia gas connection	1/2"	1/2"	1/2"	1/2"	3/4"	3/4"	3/4"	3/4"	3/4"

6 TECHNICAL DATA

Each blower motor is a three speed motor. The blower can be used on 3 different speeds. The units leaving the factory are set to the standard speed as mentioned in table 4b. The curves as shown in the figures below, illustrate for each unit which speeds can be chosen in order to get another air duty. Speeds not illustrated in the curves mean that these are not applicable (means : unit should not be set to that speed).

To use the blower on a different speed, the electrical connection of the blower motor needs to be changed. This has to be done in the electrical connection box mounted on the blower itself. Inside the box, the 230V power supply wire is connected to the terminal of the standard speed. For changing speeds, you have to reconnect this wire to the terminal that corresponds to the desired speed (see wiring diagram inside service panel unit).

Table 4a : Gas category

Country	Gas category	Country	Gas Category
Belarus	I12H3+	Montenegro	I12H3+
Bulgaria	I2H or I3B/P	New Zealand	I12H3+
China	I12H3+	Norway	I12H3 B/P
Czech Republic	I12H3+	Poland	I12H3P
Croatia	I12H3P	Portugal	I12H3+
Cyprus	I12H3+	Romania	I12H3P
Denmark	I12H3 B/P	Russian Federation	I2H or I3P
Estonia	I12H3+	Serbia	I12H3+
Finland	I12H3 B/P	Slovakia	I12H3+
Greece	I12H3+	Slovenia	I12H3+
Hungary	I12HS3P	Spain	I12H3+
Iceland	I12H3+	Sweden	I12H3 B/P
Latvia	I12H3+	Turkey	I12H3+
Lithuania	I12H3+	Ukraine	I2H or I3P

Table 4b : Technical data

UDSBD-4E		015	020	025	030	035	043	050	055	064
Gas category		see table 4a								
Comb. Air & Flue, type B instal. ¹		B22								
Comb. Air & Flue, type C instal. ¹		C12, C32, C42, C52, C62, C82								
Flue & combustion air connection collars	mm	80	80	100	100	100	100	100	130	130
Heat input (Hs)	kW	17,6	22	30,8	35,2	42,2	50,8	58,6	66	77,7
Heat input (Hi)	kW	15,9	19,8	27,8	31,7	38	45,8	52,8	59,5	70
Heat output	kW	14,6	18,2	25,5	29,2	34,9	42,1	48,6	54,7	64,4
Thermal efficiency	%	92	92	92	92	92	92	92	92	92
Gas consumption rate										
Nat. gas G20	m ³ /h	1,68	2,1	2,94	3,36	4,02	4,85	5,59	6,3	7,41
Prop. G31	kg/h	1,24	1,55	2,16	2,47	2,96	3,57	4,12	4,64	5,46
Gas connection size (not supply line size) ²		1/2"					3/4"			
Temperature rise ³	K	20	23	27	25	25	31	29	30	32
Airflow ³	m ³ /h	2150	2350	2750	3360	4080	3900	4900	5300	5930
Nominal motor speed	rpm	950	950	1430	1430	950	950	950	950	950
Standard low, mid or high speed		mid	high	low	mid	low	low	mid	mid	high
Recommended mounting height ⁴	m	3,5	4	4,5	4,5	5,5	5,5	6	6	6
Horizontal air throw ⁵	m	18	23	26	26	32	34	38	38	38
Sound pressure ⁶	dB(A)	50	52	47	51	46	47	52	50	53
Sound pressure ⁷	dB(A)	57	58	54	58	53	54	59	57	60
Electrical service (protection class IP20)		230/240V 1N ~ 50 Hz								
Total electrical rating	W	496	496	1662	1662	1700	1700	1700	1700	1700

- 1) Gas Appliance Classifications for Approved Venting Methods based on CEN-report CRI749:2001.
- 2) There is a difference between the gas connection diameter and the diameter of the supply line. Always use the most adequate diameter of the supply line to minimize the pressure drop through the gas pipes - if necessary, reduce the diameter of the supply line at the inlet of the unit.
- 3) Figure for discharge louvre zero deflection.
- 4) Height from floor to bottom surface of heater. These are recommendations only. Positioning of unit heaters for proper performance is application dependent. Operation is affected by other air moving equipment in the space, obstructions to the airflow, draughts and/or close proximity to doors or windows, etc ... **Care should be taken to avoid mounting the heaters above these recommendations, unless downturn nozzle options are used, as significant stratification may occur resulting in poor floor coverage and higher energy losses through the roof structure.**
- 5) Isothermal conditions +/-20°C ambient air temperature, discharge louvres zero deflection, v = 0,5m/s. The air throw will be influenced by the height of the building, mounting height of the unit, ambient temperature & adjustment of the louvres.
- 6) Sound pressure level in dB(A) in free field conditions, measured at 5 meters from the unit, free outlet
- 7) Sound pressure level in dB(A), measured at 5 meters from the unit with A=160m² & Q=2, free outlet

Figure 2c : Blower curves for UDSBD035-4E

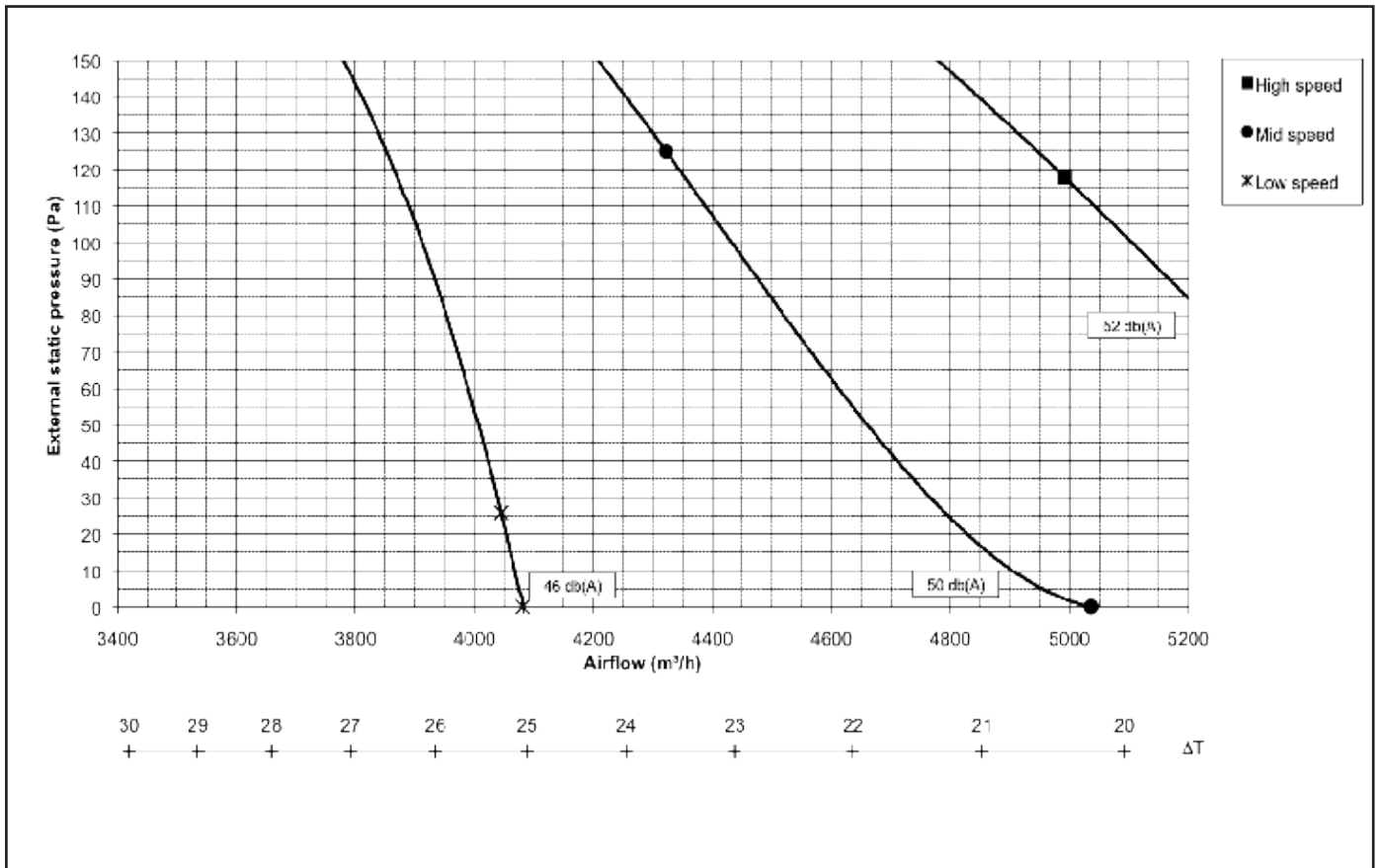

Figure 2d : Blower curves for UDSBD043-4E

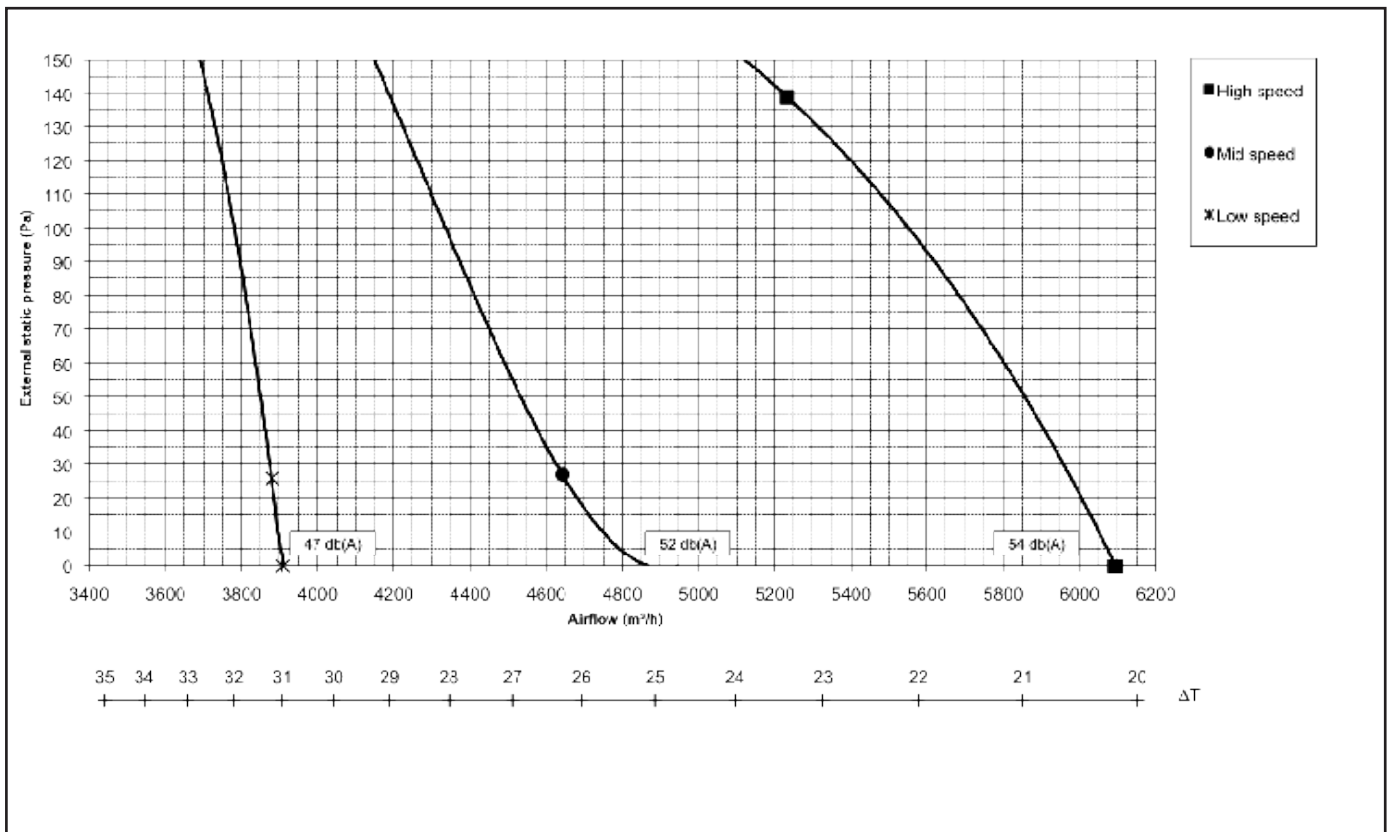

Figure 2e : Blower curves for UDSBD050-4E

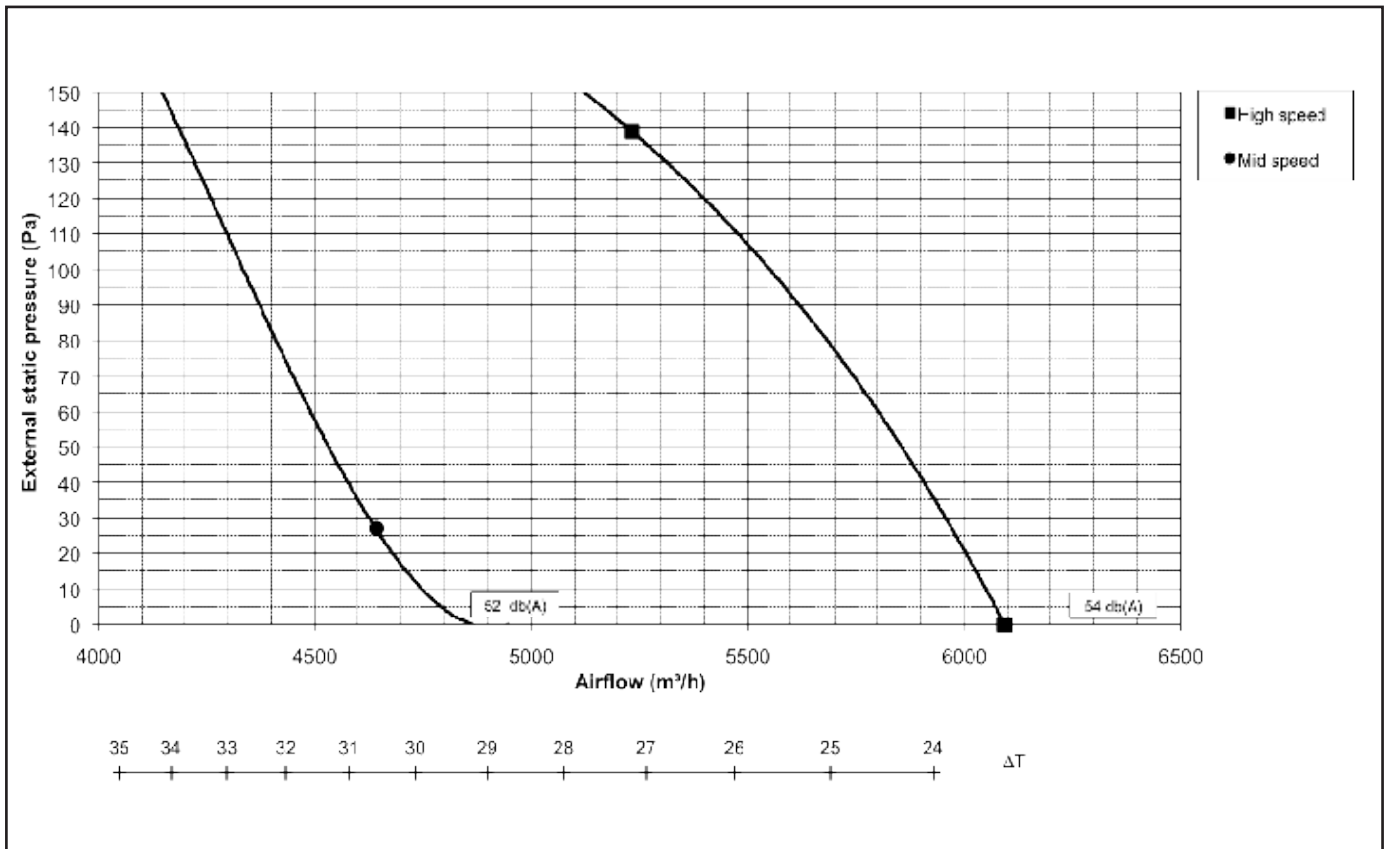

Figure 2f : Blower curves for UDSBD055-4E

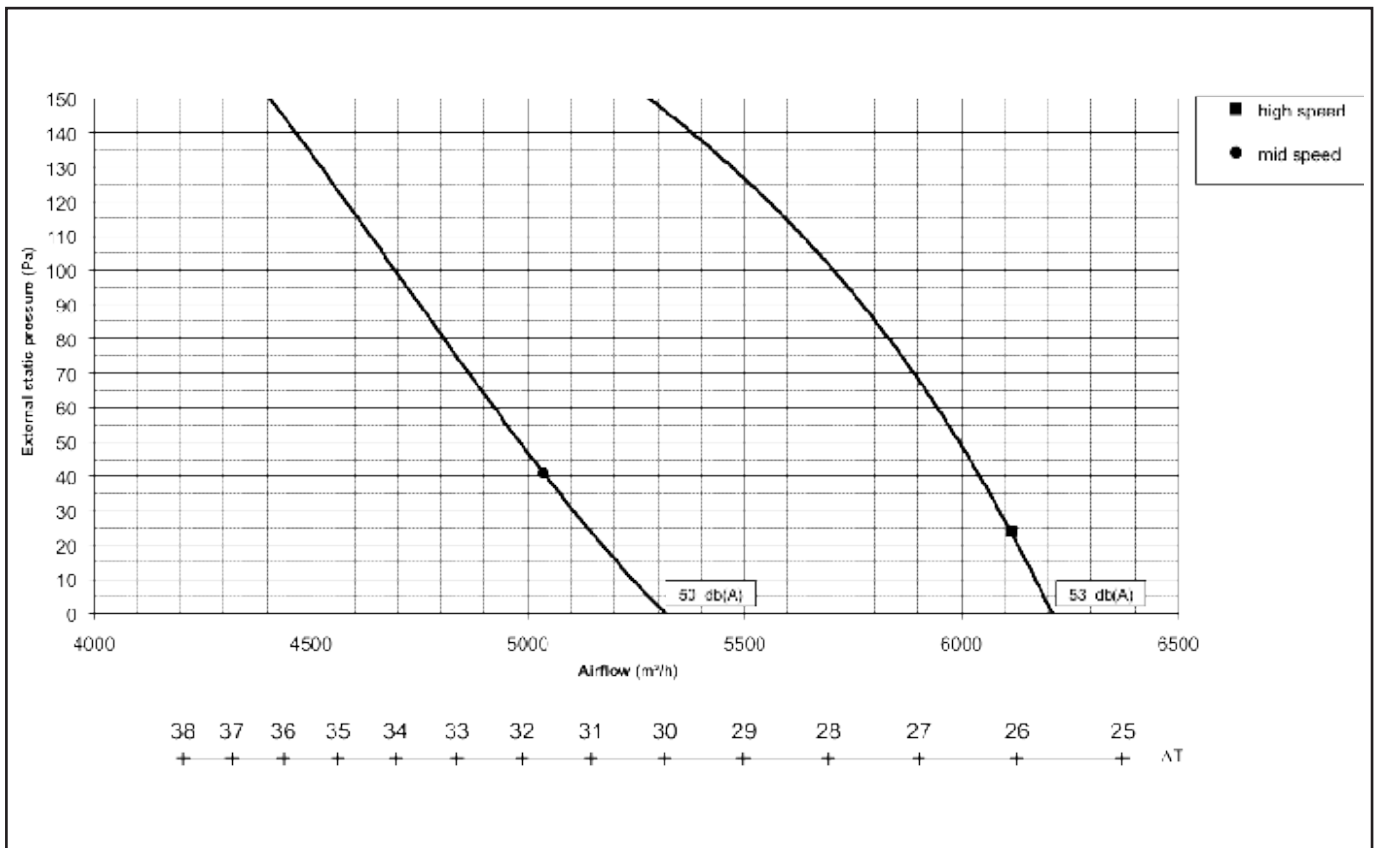
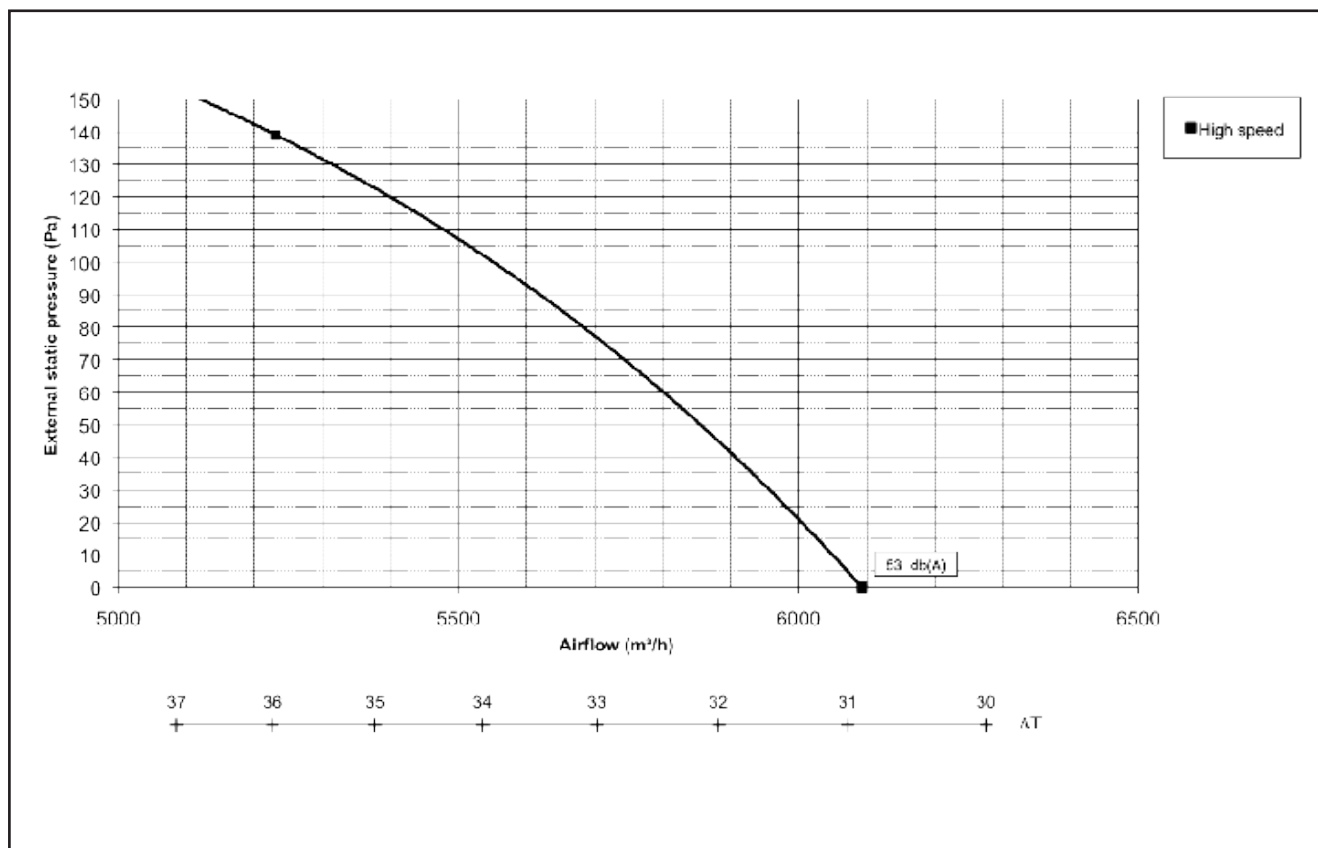

Figure 2g : Blower curves for UDSBD064-4E



7 FLUE REQUIREMENTS

Model UDSBD-4E heaters may be installed as Type-B and Type-C installations.

Local requirements may apply in addition to national requirements. These unit heaters are designed to operate safely and efficiently with either a horizontal or vertical flue system when installed with the specific requirements and instructions.

If this heater is replacing an existing heater, be sure that the flue is sized properly for the heater being installed and that the existing flue is in good condition. A properly sized flue system is required for safe operation of the heater. An improperly sized flue system can cause unsafe conditions and/or create condensation.

The air heaters may be installed as a balanced flue (type C) heater requiring both a combustion air inlet duct and a flue pipe or as a power vented heater (type B) (the combustion air is taken from the space where heater is installed), which requires only a flue pipe exhausting to outdoors.

Each heater installed as a type B appliance must be fitted with an individual flue pipe and the combustion air inlet opening is provided with a protection grill. Each heater installed as a type C appliance must be fitted with an individual combustion air/flue pipe system. Type C2 appliance, with single duct system for supply of combustion air and evacuation of flue gasses, are not allowed.

IMPORTANT :

The flue must be installed in accordance with national and local regulations. Failure to provide proper flueing could result in death, serious injury and/or property damage. The air heater must be installed with a flue to the outside of the building. Safe operation of any power vented gas apparatus requires a properly operating flue system, correct provision for combustion air and regular maintenance and inspection.

Diameter & maximum flue pipe lengths

Flue pipe diameters and maximum pipe lengths in table 5 apply to both **horizontal** and **vertical** systems. Add **all** straight sections and equivalent lengths for elbow.

The total combined length **must not exceed** the maximum flue length.

Table 5 : maximum flue system pipe lengths

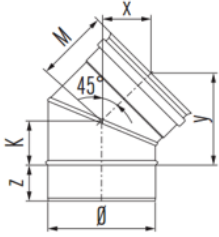
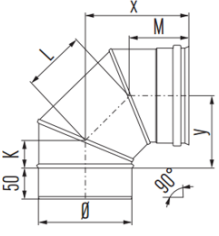
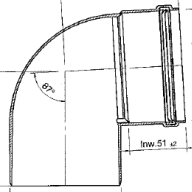
UDSBD-4E				015-020	025→050	055→064
Heater socket & pipe dia		mm	Flue pipe/Inlet pipe	80	100	130
Max straight length		m	Flue pipe/Inlet pipe	9	9	9
Equivalent length of 45° elbow		m	Flue pipe/Inlet pipe	0,75	0,75	0,75
Equivalent length of 90° elbow		m	Flue pipe/Inlet pipe	1,5	1,5	1,5
Equivalent Length of 90° elbow		m	Flue pipe/Inlet pipe	2,5	2,5	n.a

- Use only one flue pipe diameter on an installation.
- Recommended minimum flue is 1m.
- * Mentioned lengths only apply when :
 - no elbow installed immediately after flue and inlet
 - successively installation of several elbows without straight pipe

FLUE OUTLET

Venter outlet attachment requirements:

Depending on the size of flue pipe as determined in table 5, attach either the flue pipe directly to the collar or a taper-type connector.

Attention :

Single wall flue pipe exposed to cold air or run through unheated areas should be insulated. Where condensation is unavoidable, provision must be made for the condensation to flow freely to a point to which it can be released, i.e. a drain or gully. The condensation drain from the flue must be constructed from non-corrodible material not less than 20 mm diameter. Copper or copper based alloys must not be used for condensation drains.

The port must be at least 450 mm away from the air heater flue connection socket. Follow the flue pipe manufacturers installation instructions for making joints, including connections to the air heater, for passing through a building element and for support requirements.

Single wall flue seamless aluminium or stainless steel pipes are required. All joints must be sealed to prevent products of combustion from leaking into the building. If the flue passes through a combustible element of the building it must be enclosed by a sleeve of non-combustible material and separated from the sleeve by a minimum of 25 mm air break. The temperature of any combustible material near to the flue must not exceed 65°C when the heater is in operation. The flue must be at least 150 mm away from any combustible material.

FLUES FOR POWER VENTED INSTALLATIONS (type B appliances)

If the air heater is to be installed as a type B appliance, air for combustion will be taken from within the space where the heater is installed. Ensure that an adequate air supply for combustion and ventilation is provided within the building in accordance with BS6230/BS5440 plus other relevant regulations & rules in force.

Figure 3 : Approved appliances type B

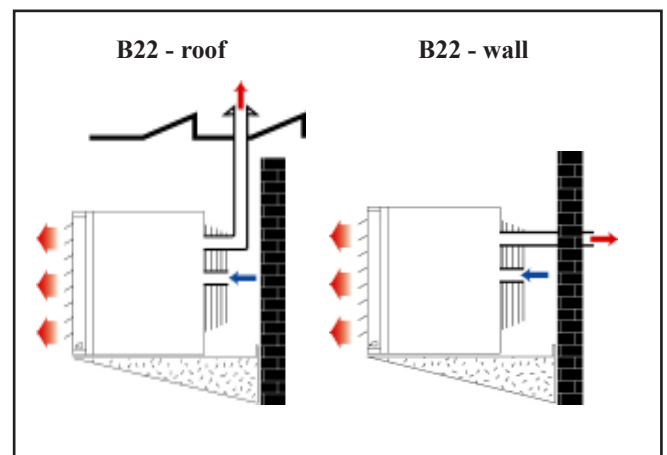

**Figure 4 : Type B appliances :
Combustion air and flue pipe sockets**

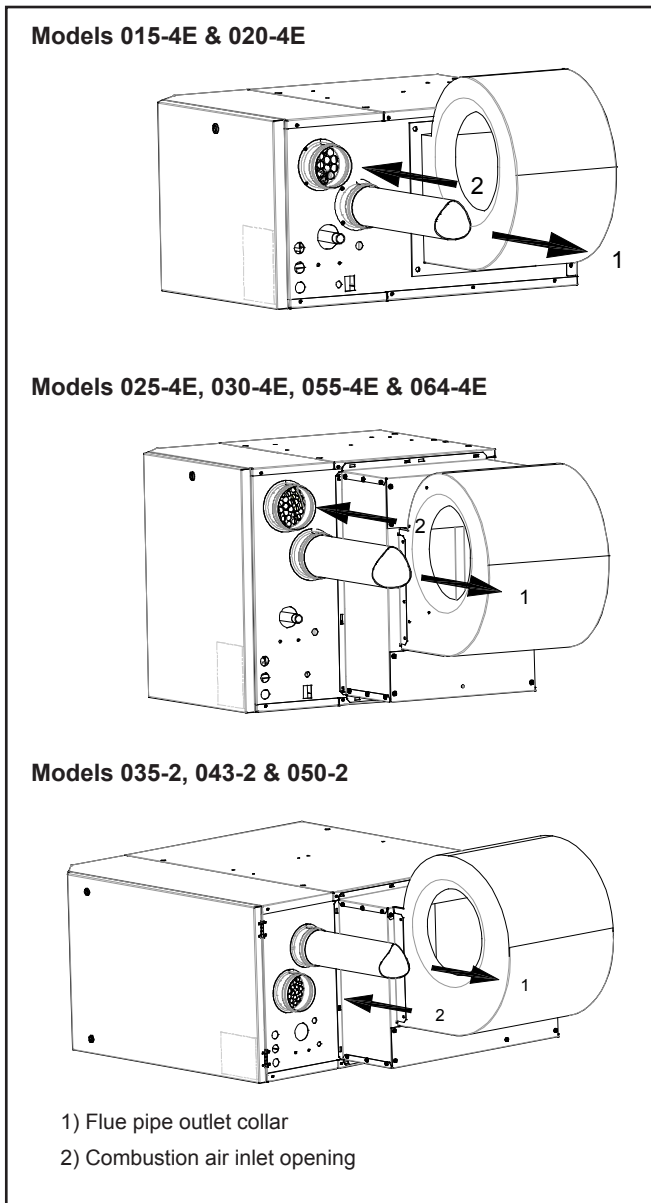

AIR SUPPLY

When these air heaters are installed in type B applications, designed to take air for combustion from the space in which it is installed. Do not restrict the combustion air intake.

It is important to ensure that there is an adequate air supply at all times for both combustion and heating requirements. Modern buildings involve greater use of insulation, improved vapour barriers, and weather proofing. These practices mean that buildings are sealed much tighter than in the past.

Proper combustion air supply for a power vented Type B installation requires ventilation of the heated space. Natural infiltration of air may not be adequate. Use of exhaust fans aggravates this situation. It is important to ensure that there is adequate combustion air supply at all times. Reliance on doors and windows is not allowed.

Always ensure that adequate combustion air is provided to suit the total installation of all combustion equipment in accordance with BS6230 or BS5440 as appropriate.

Ensure that the air combustion inlet opening at the rear side of the unit cannot be obstructed (cfr. fig. 3).

Combustion air inlet pipe & flue pipe for balanced flue installation (type C appliances)

Balanced flue air heaters are designed to be fitted with a combustion air inlet duct that obtains outdoor air and a flue pipe that exhausts flue products to outdoors. Both the flue and combustion air pipes must be sealed. Use gasket sealed seamless aluminium or stainless steel pipe or equivalent. For testing, the flue pipe should include a sealable test port.

Type C2 appliances must not be applied !

Figure 5 : Approved appliances type C

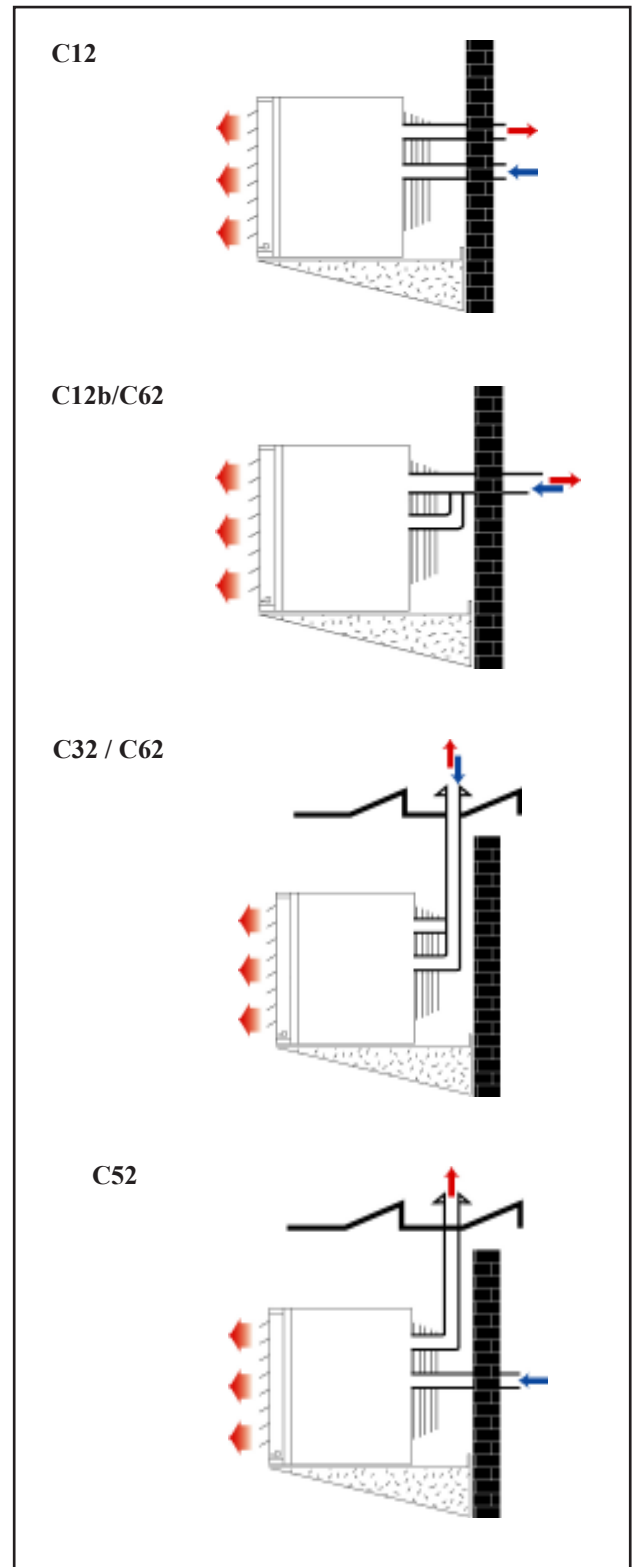
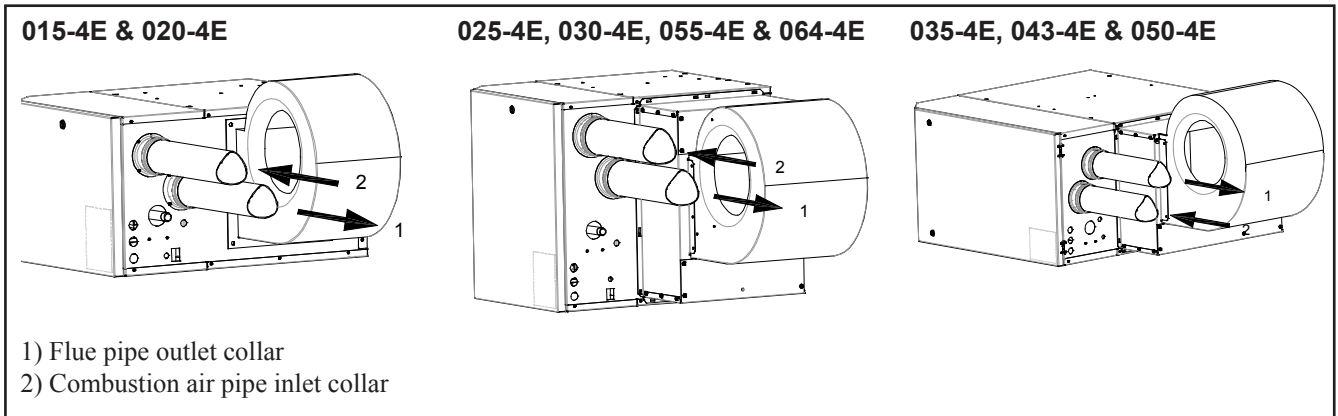

Figure 6 : Type C appliances : Combustion air and flue pipe sockets



8 LOCATION HEATER

Warning:

If touched, the vent pipe and internal heater surfaces that are accessible from outside the heater will cause burns. Suspend the heater such that these components cannot be touched.

Remark:

Flue requirements may affect location. Consult section 7 before making a final determination.

Use the minimum clearances in section 5 and the throw data in the technical data table of section 6 when determining where to suspend the heater.

For best results, the heater should be placed with certain rules in mind. Always ensure that minimum clearances are maintained. Locating a unit heater above the maximum recommended height can result in significant air stratification. When possible, heaters should be arranged to blow toward or along exposed wall surfaces.

Suspended heaters are most effective when located as close to the working zone as possible, but care should be exercised to avoid directing the discharged air directly on to room occupants. Partitions, columns, counters, or other obstructions should be taken into consideration when locating the unit heater so that a minimum quantity of airflow will be deflected by such obstacles. When units are located in the centre of the space to be heated, the air should be discharged toward the exposed walls. In large areas, units should be located to discharge air along exposed walls with extra units provided to discharge air in toward the centre of the area. For optimum results heaters are best used in conjunction with recirculating air fans suspended at high level.

At those points where infiltration of cold air is excessive, such as at entrance doors and shipping doors, it is desirable to locate the unit so that it will discharge directly toward the source of cold air, typically from a distance of 4.5 to 6.0 meters or install a downflow unit over the door opening.

Caution : Do not locate the heater where it may be exposed to water.

Hazards of Chlorine - apply to the location of the combustion air inlet

The presence of chlorine vapours in the combustion air of gas-fired heating equipment presents a potential corrosion hazard. Chlorine, found usually in the form of freon or degreaser compounds when exposed to a flame will precipitate from the compound, and go into solution with any condensation that is present in the heat exchanger or associated parts. The result is hydrochloric acid which readily attacks all metals. Care should be taken to separate these vapours from the combustion process. This may be done by wise location of the unit flue and combustion air terminals with regard to exhausters or prevailing wind directions. Chlorine is heavier than air. Keep this fact in mind when determining installation location of the heater in relation to building exhaust systems.

Where chlorine vapours are prevalent heaters with special grade 316 A1SI stainless steel heat exchangers are recommended.

9 HANGING THE HEATER

Warning:

Check the supporting structure to verify that it has sufficient load-carrying capacity to support the unit weight. Suspend the heater only from the threaded nut retainers or with a manufacturer provided kit. **DO NOT** suspend from the heater cabinet panels. Do not place or add additional weight to the suspended heater.

Before suspending the heater, check the supporting structure to verify that it has sufficient load-carrying capacity to support the weight of the unit.

Table 6 : Weights

UDSBD-4E	015	020	025	030	035
kg	50	53	71	74	125

UDSBD-4E	043	050	055	064
kg	131	131	148	153

Leave the unit on the pallet. If the bottom of the unit is not supported or protected damage can occur.

The heater is supplied with four point suspension. All points must be used. Two threaded nut retainers are provided on each side of the top of the heater. See figure 6 for hanger rod size.

Figure 7 : Suspending the heater with rods from the threaded nut retainers

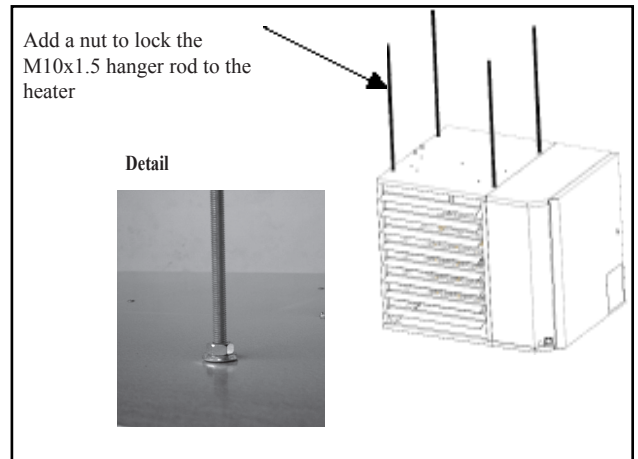

Be sure that the threaded hanger rods are locked to the heater as illustrated in figure 6. Recommended maximum hanger rod length is 1.8m. Where longer drops are required, ensure that restraints are fitted to prevent excess lateral movement and supports are adequately sized.

10 GAS PIPING & PRESSURES

All piping must be in accordance with requirements outlined in the National Gas Codes (different for each country). Gas supply piping installation should also conform with good practice and any local codes. Support gas piping with pipe hangers, metal strapping, or other suitable material. **Do not rely on the heater to support the gas pipe.**

All sealing products shall be resistant to the action of liquefied petroleum gas or any other chemical constituents of the gas being supplied.

Install a ground joint union and manual shutoff the gas cock upstream of the unit control system.

The unit is equipped with a nipple that extends outside the cabinet. The gas connection is 1/2" or 3/4", dependent on the size of the unit.

Leak test all connections by brushing on a leak detecting solution.

Table 7 : Diameter gas connection

UDSBD-4E	Nat gas/ Propane
Model 015 through 030	1/2"
Model 035 through 064	3/4"

Warnings:

All components of a gas supply system must be leak tested prior to placing equipment in service. **NEVER TEST FOR LEAKS WITH AN OPEN FLAME.** Failure to comply could result in personal injury, property damage or death.

This appliance is equipped for a maximum gas supply pressure of 50 mbar.

Pressure testing supply piping

Test pressures above 50mbar : Disconnect the heater and manual valve from the gas supply line which is to be tested. Cap or plug the supply line.

Test pressures below 50mbar : Before testing, close the manual valve on the heater.

Figure 8 : gas connection

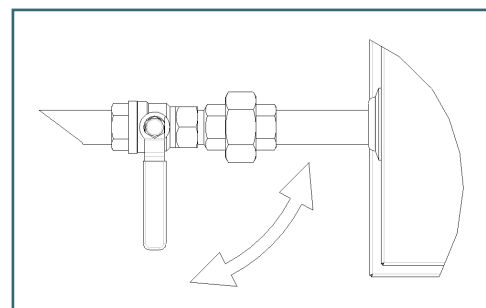

11 ELECTRICAL CONNECTION

DANGER : THIS APPLIANCE MUST BE EARTHED.

The electrical installation may only be carried out by an appropriately qualified person current to IEE Regulations. The supply line to the heater should include a main switch. The minimum **clearance** distance between the contacts must be more than 3 mm.

All electrical connections should be made in the heater control compartment. Screw type terminals are provided. Connections should be in accordance with the terminal markings and the wiring diagram affixed to the air heater.

Attention :

Serious damage can occur to burner relay when faulty connection of thermostat, reset switch or burner failure lamp.

Switching of wires for reset switch and flame failure (e.g. in a remote control box) will destroy the burner relay.

The minimum external control required for the air heater is a room thermostat. **It is essential that the main input line and neutral to terminals L and N remain live at all times even when the heater is switched off to ensure correct operation of the unit.**

A polarisation switch with green indicator light is fitted inside the heater to check if Line, Neutral and Earth are connected correctly. If this is the case, the green light will glow when pushing on the switch. If the light does not glow, check earth, line and neutral connections.

A burner reset switch with red indicator light is fitted on the heater. To add a remote reset button, make connections to the terminals in the electric box as indicated on the wiring diagram.

IMPORTANT:

If the reset button requires activating for any reason, the cause must be determined. After determining and correcting the problem, restart the heater and monitor long enough to ensure proper operation (approx. 5 minutes).

An orange indicator light is fitted on the heater to signify when the burner is on.

Ensure that all cables and installers wiring are fixed to the gas pipe and that they do not touch the combustion collector box.

THERMOSTAT LOCATION

Do not attempt to control more than 1 air heater from a single thermostat or control panel unless a properly wired relay is fitted. Follow the instructions supplied with such panels.

The location of the room thermostat or sensor is very important. It should not be positioned on a cold wall or cold surface. Avoid location in draughty areas or where it may be influenced by heat sources e.g. the sun, process plant, etc. The thermostat should be mounted on a vibration free surface and mounted about 1,5 metres above floor level. Follow the thermostat manufacturers instructions. The thermostat must be suitable for potential free contacts.

12 START-UP

Check the installation prior to start-up

- Check suspension. Unit must be secure. Verify that no other parts are fitted which are not individually supported and secured.
- Check clearances from combustibles. Requirements are in section 5.
- Check vent system to be sure that it is installed according to the instructions in section 7, venting requirements.
- Check piping for leaks and proper gas line pressure. Bleed gas lines of trapped air.
- Check electrical wiring and ensure that wiring conforms with the wiring diagram. Be sure all wire sizes meet requirements.
- Check polarity. Verify that line voltage exists between the black "L1" and earth ground.
- Verify that the appliance is earthed by conducting an earth continuity test.

Heater start-up

Warning:

For your safety, follow the instructions exactly otherwise damage or injury could occur.

- This heater does not have a pilot flame. It is equipped with an ignition device which automatically lights the burner. Do not try to light the burner by hand.
- Before operating, smell all around the heater area for gas. Be sure to smell next to the floor because propane gas is heavier than air and will settle near the floor.
- Do not use this appliance if any part has subjected to water ingress. Immediately call a qualified service technician to inspect the appliance and to replace any part of the control system and any gas control.
- When overheating occurs or when gas supply is not turned off, shut the manual gas tap before turning off the electric power.

Operating instructions and operating sequence

1. Set thermostat to the lowest setting.
2. Turn off all electric power to the heater.
3. Shut the gas cock at the inlet of the unit.
4. Wait five (5) minutes to clear out any gas. Then smell for gas, including near the floor. If you smell gas, STOP! and follow the steps in the WARNINGS printed on page 3. If you do not smell gas, proceed to the next step.
5. Turn on the electric power to the heater.
6. Open the gas cock at the inlet of the unit.
7. If fitted, ensure that a time switch is set to an 'ON' period.
8. Adjust the thermostat to the required setting (must be above current room temperature).

If the appliance does not operate, follow the instructions "To turn off gas supply at the Appliance" printed below and call your service technician.

9. Thermostat calls for heat, energizing the venter motor.
10. When adequate air flow for combustion is proven by an air proving switch and a prepurge period has elapsed, the integral ignitor and multifunctional gas control operate. The ignition spark ignites the gas creating the burner flame.
11. Burner flame is sensed by a flame rod sensor and when the heat exchanger is warmed up (+/- 30 seconds) and the fan control relay closes, the fan motor is energized.
12. If the flame is extinguished during the main burner operation, the integrated control system closes the main valve and attempts to relight the burner. The unit will attempt 5 ignitions before entering a "lock out" mode. Lock out is indicated by the red warning light on the heater. To end this mode push on the reset switch.
13. To turn the heater 'OFF' for short periods : adjust the room thermostat to its lowest setting or 'OFF'. The fan will continue to run to cool the heater and then switch off automatically.
14. To turn the heater 'OFF' for long periods : see 'To turn off gas supply at the appliance' below.

Check installation after start-up

TO TURN OFF GAS SUPPLY AT THE APPLIANCE

- 1) Set thermostat to the lowest possible setting or 'OFF' position.
- 2) Shut off the gas tap when the fan has stopped.
- 3) Switch off electric power to the appliance.

- Check gas pressure as described in detail below.
- Turn the unit off and on, pausing 2 minutes between each cycle. Observe for smooth ignition.
- Set the thermostat to the required room temperature.
- Place this booklet and any control or optional information in an accessible location near the heater or give this information to the end user.

Burner gas pressure adjustment

The gas pressure is set for the required heat input before the appliance leaves the factory. Provided that the gas supply to the air heater is in accordance with the supply pressure described on the appliance data plate, the operating pressure will not require adjustment. To check the pressure use the following procedure:

- * Ascertain from the heater's data plate the correct operating gas pressure;
- * Turn the room thermostat control to its lowest setting;
- * Remove the screw from the burner pressure test point of the multi-functional control valve. Connect a manometer to the test point(see figures 9 & 10);
- * Adjust the room thermostat to call for heat i.e. above room ambient temperature;
- * Observe the burner gas pressure on the manometer and compare to the required pressure on the data plate;
- * If necessary, adjust the burner gas pressure. Remove the cover screw (models 035-4E- >100-4E) or cover cap (models 011-4E->030-4E). To adjust low fire, use the lower copper ring - to adjust high fire, use the upper plastic ring;
- * Set room thermostat to lowest setting to turn OFF the burners. Replace the test point screw/cap and with the main burner OFF, test for gas soundness using a leak detector fluid.

Reset temperature control/room thermostat to comfort operating level.

Figure 9 : Gas valve types 015-4E -> 043-4E

Figure 10 : Gas valve types 050-4E -> 064-4E

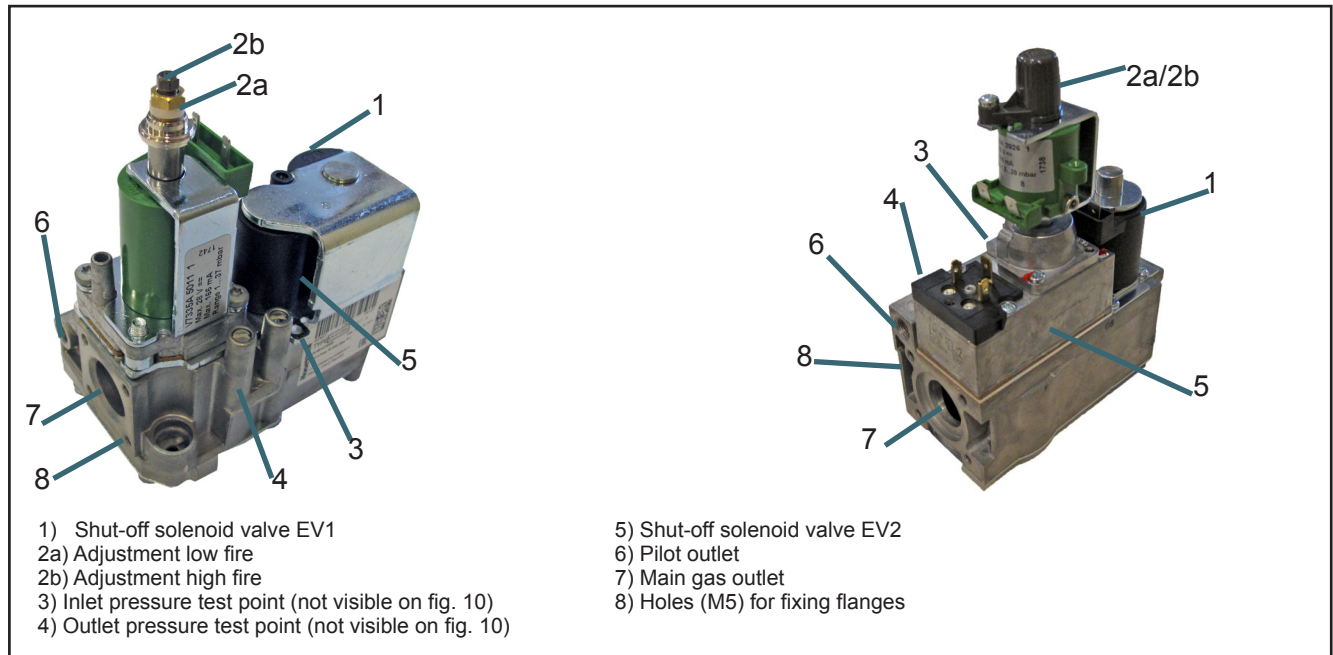

Table 8 : Burner jets and pressures

*Belarus, China, Croatia, Czech Republic, Cyprus, Estonia, Greece, Iceland, Latvia, Lithuania, Montenegro, New Zealand, Portugal, Serbia, Slovenia, Slovakia,

			015-2	020-2	025-2	030-2	035-2	043-2	050-2	055-2	064-2	
Nat.Gas (G20)	Burner jet	dia	3,70	4,20	4,80	5,30	5,75	6,50	6,80	7,10	8,00	
	Burner pressure	mbar	7,80	7,10	8,20	7,50	7,90	7,10	7,90	8,40	7,90	inlet pressure 20 mbar
Prop. (G31)	Burner jet	dia	1,19	2,15	2,60	2,80	3,10	3,35	3,70	3,90	4,15	
	Burner pressure	mbar	36,90	36,90	36,80	36,80	36,00	35,90	35,80	35,70	35,60	inlet pressure 37 mbar

*Romania, Poland

			015-2	020-2	025-2	030-2	035-2	043-2	050-2	055-2	064-2	
Nat.Gas (G20)	Burner jet	dia	3,70	4,20	4,80	5,30	5,75	6,50	6,80	7,10	8,00	
	Burner pressure	mbar	7,80	7,10	8,20	7,50	7,90	7,10	7,90	8,40	7,90	inlet pressure 20 mbar
Prop. (G31)	Burner jet	dia	2,10	2,25	2,80	2,95	3,30	3,50	3,80	4,10	4,40	
	Burner pressure	mbar	29,90	29,90	29,80	29,80	28,90	29,30	28,80	28,40	28,50	inlet pressure 30 mbar

*Hungary, Russian Federation, Ukraine

			015-2	020-2	025-2	030-2	035-2	043-2	050-2	055-2	064-2	
Nat.Gas (G20)	Burner jet	dia	3,70	4,20	4,80	5,30	5,75	6,50	6,80	7,10	8,00	
	Burner pressure	mbar	7,80	7,10	8,20	7,50	7,90	7,10	7,90	8,40	7,90	inlet pressure 25 mbar
Prop. (G31)	Burner jet	dia	1,19	2,15	2,60	2,80	3,10	3,35	3,70	3,90	4,15	
	Burner pressure	mbar	36,90	36,90	36,80	36,80	36,00	35,90	35,80	35,70	35,60	inlet pressure 50 mbar

*Bulgaria, Denmark, Finland, Norway, Sweden

			015-2	020-2	025-2	030-2	035-2	043-2	050-2	055-2	064-2	
Nat.Gas (G20)	Burner jet	dia	3,70	4,20	4,80	5,30	5,75	6,50	6,80	7,10	8,00	
	Burner pressure	mbar	7,80	7,10	8,20	7,50	7,90	7,10	7,90	8,40	7,90	inlet pressure 20 mbar
Prop. (G31)	Burner jet	dia	1,19	2,15	2,60	2,80	3,10	3,35	3,70	3,90	4,15	
	Burner pressure	mbar	28,90	28,90	28,80	28,80	29,20	29,20	29,00	28,90	28,90	inlet pressure 30 mbar

$$\text{Burner pressure low fire} = \frac{\text{burner pressure high fire}}{4}$$

IGNITION SYSTEM

This heater is equipped with a direct spark integrated control relay. The control relay monitors the safety devices and controls the operation of the venter motor and the gas valve between heat cycles. The time line below illustrates a normal heat cycle.

Normal heat cycle operating sequence

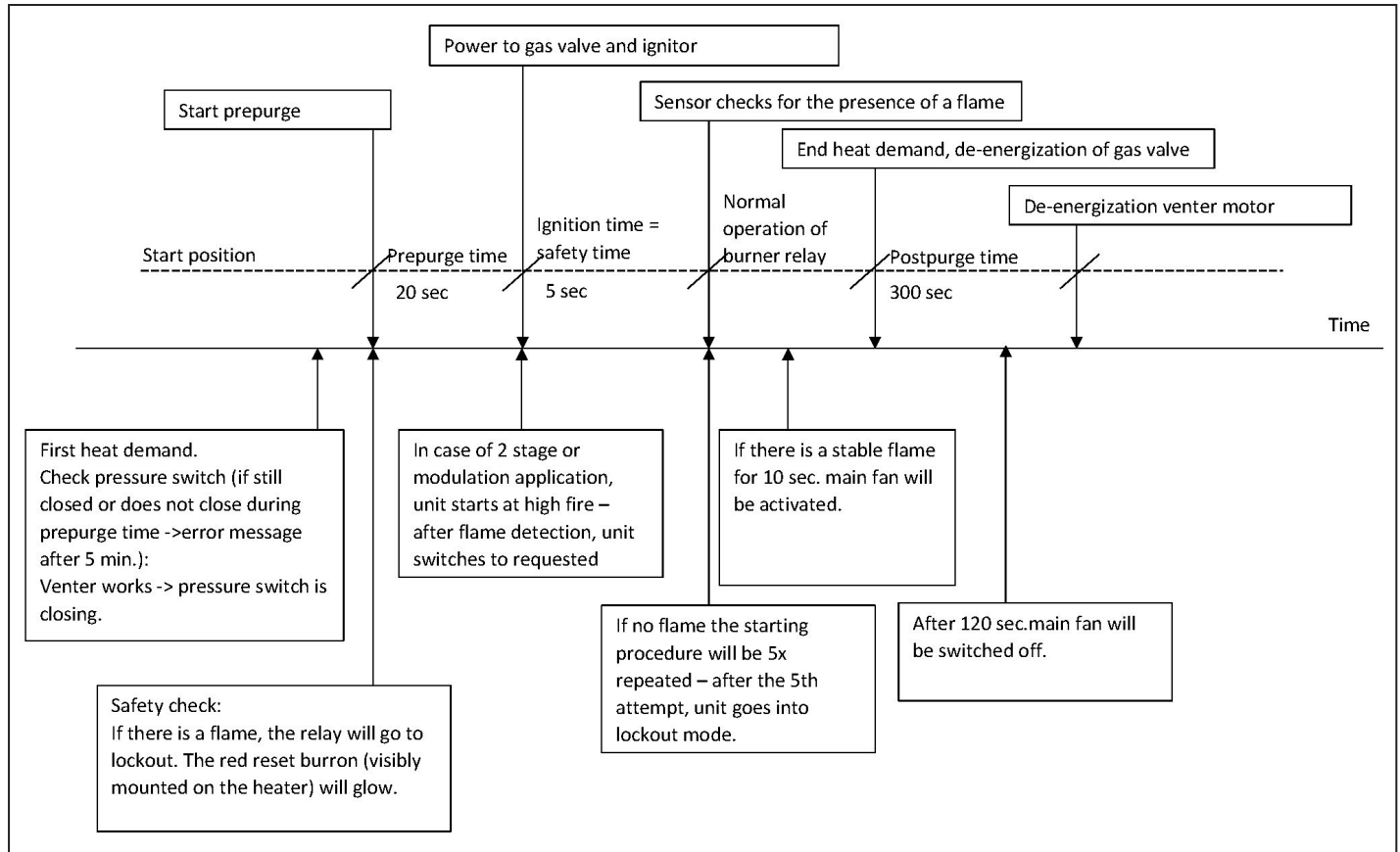

Definitions

Start position: The system is not in lock-out position and can proceed with the start-up sequence upon a demand for heat.

Pre-purge time: This is a period of 20 seconds during which the combustion fan (venter) operates prior to activation of the ignition device.

Safety time: The safety time is the delay between the gas valve being energised and the flame sensor checking for the presence of a flame. This is a period of 5 seconds.

Note: If no flame is sensed, the burner relay will **attempt ignition 5 times before going into lock-out mode.**

Post-purge time: This is the time of 10 seconds between burner shut-down and the moment the combustion fan (venter) is de-energized.

13 MAINTENANCE/SERVICE

Warning: If you turn off the power supply, always turn off the gas.

The material contained in the MAINTENANCE AND SERVICE Section of this manual is designed to aid a qualified service technician in maintaining and servicing this equipment. This heater will operate with a minimum of maintenance. To ensure long life and satisfactory performance, a heater that is operated under normal conditions should be in-

spected and cleaned at the start of each heating season (inspection and maintenance at least once a year). If the heater is operating in an area where an unusual amount of dust or other impurities are present in the air, more frequent maintenance is recommended.

When any service is completed, be careful to reassemble correctly to ensure that no unsafe conditions are created. When starting the heater, always follow the lighting instructions on the heater.

Maintenance Schedule - The following procedures should be carried out at least once each year (See figure 11a) :

- Clean all dirt, lint, and grease from the fan blade, fan guard, and motor.
- Check the heat exchanger both internally and externally for evidence of physical damage.
- Check the burner for scale, dust, or lint accumulation. Clean if required.

- Check the vent or vent/combustion air system for soundness. Replace any parts that do not appear sound.
- Check the wiring for any damage. Replace damaged wiring.

NOTE: If replacement parts are required, use only factory-authorized parts.

Figure 11a : Location of controls

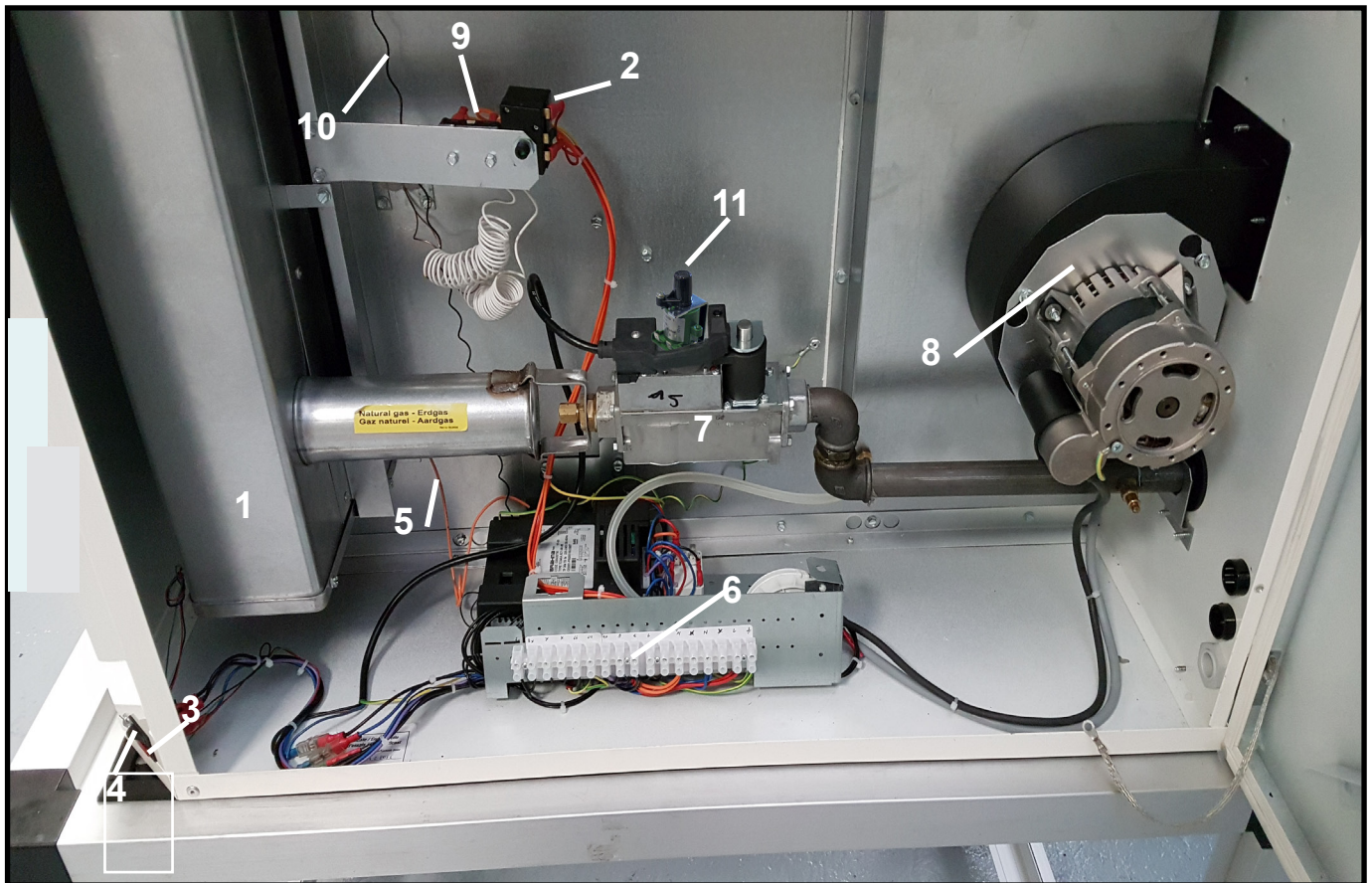

- | | |
|-------------------------------------|-------------------------------|
| 1) Burner | 7) Main gas valve (V1) |
| 2) LC3 limit control | 8) Venter motor. |
| 3) Burner operating led | 9) Limit control LC1 |
| 4) Reset switch (S5)+burner lockout | 10) Flame sensor (IS) |
| 5) Spark ignitor (ER) | 11) Modulating gas valve (VM) |
| 6) Control panel | |

Figure 11b - Control panel assy located on a removable bracket

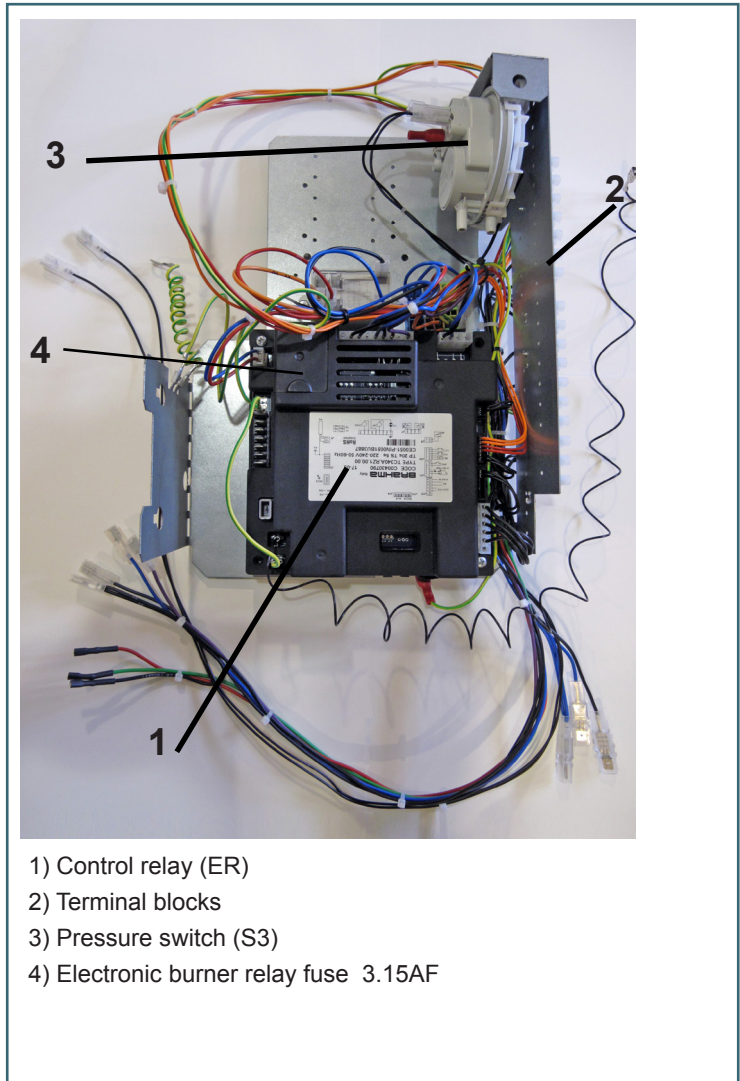

14 HEAT EXCHANGER MAINTENANCE

This heater is equipped with a patented T-CORE²® heat exchanger.

Remove any external dirt or dust accumulation. Visually check the heat exchanger for cracks and holes. If a crack or hole is observed, replace the heat exchanger.

15 BURNER MAINTENANCE

This heater has a unique one-piece T-CORE² burner assembly designed to provide controlled flame stability without lifting or flashback. The burner can be removed as a unit for inspection or service : see below for removal instructions.

Instructions for burner removal

1. Outside the cabinet, shut the gas supply off at the manual valve ahead of the union
2. Turn off the electric supply.
3. Disconnect the gas supply at the union outside of the cabinet.
4. Open the access door.
5. **Disconnect the manifold and move it out of the way.** At the gas valve, mark and disconnect the connector. Carefully remove the burner orifice and orifice adapter locking nut. Slide the orifice adapter out through the bracket on the burner pushing the manifold to the right. This will move the manifold out of the way. Refer to figure 14 for component definitions.

Figure 12a

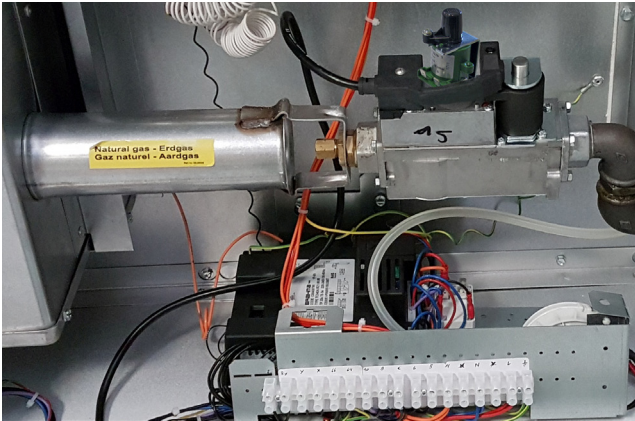
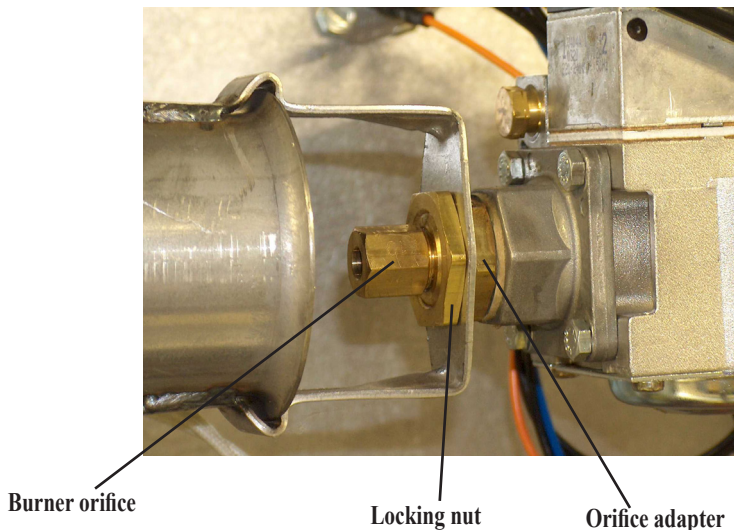

Figure 12b



Inspect the burner/control compartment annually to determine if cleaning is necessary. If there is an accumulation of dirt, dust, and/or lint, clean the compartment and follow the instructions below to remove and clean the burner.

Caution : use of eye protection is recommended.

6. Remove burner

- a) Locate the burner body front support. Remove the screws that attach it to the secondary air shield. Refer to fig. 14 for component definitions.
- b) Holding the venturi tube, slide the entire burner slightly to the right to disengage the burner from the supports on the left. Then rotate the open end of the venturi tube outward away from the heater. Carefully pull the burner assembly out of the cabinet.

Figure 13a



Figure 13b



Figure 14 - Burner removal steps

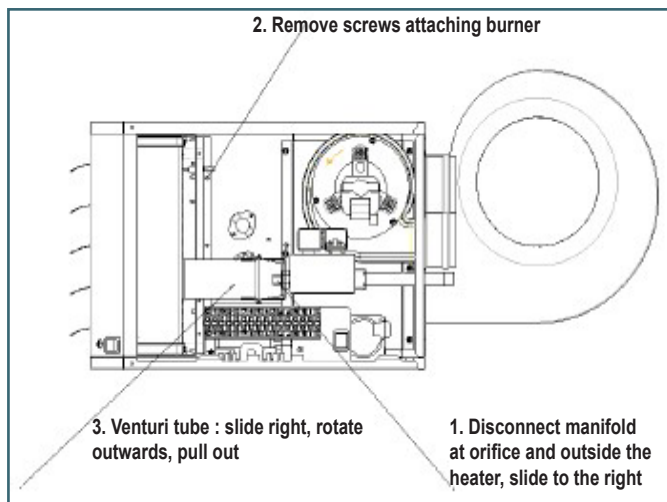

Inspect and clean the burner

With the burner assembly removed, shine a flashlight on the burner ribbons. Look for carbon buildup, scale, dust, lint, and/or anything that might restrict flow through the spaces between the burner ribbons. Holding the burner assembly so that any foreign material will fall away from the burner, use a stiff bristle brush to loosen and remove any foreign material(s). If the burner is excessively dirty, remove one of the burner end caps. Remove the four screws that hold the end cap to the burner housing. Lightly tap the end cap to remove it.

Clean all foreign material from the burner and venturi. After the burner is thoroughly clean, replace the end cap making certain that it is tight against the burner housing. NOTE: If any of the burner components are damaged or deteriorated, replace the burner assembly.

Figure 15

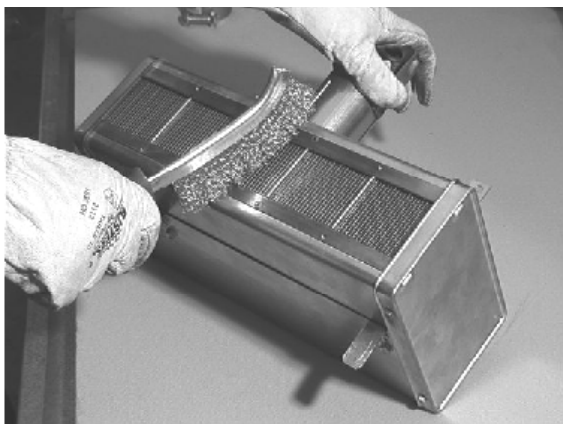

Inspect the Internal Portion of the Heat Exchanger (with burner assembly removed)

At the burner flame entrance of each tube, shine a bright light into each heat exchanger section. With the light shining into the heat exchanger, observe the outside surface of the tube where discoloration is evident. Repeat this procedure with each heat exchanger tube. If any light is observed in these high temperature regions, replace the heat exchanger.

Reinstall the burner

Repeat 'Burner removal' steps above in the opposite order.

16 BURNER ORIFICE

The burner orifice normally needs to be replaced only when a change in gas is made. When ordering a replacement orifice, provide (MJ/m³) heating value and specific gravity of gas, as well as the model and serial number of the unit. When removing or replacing the burner orifice be careful not to damage the venturi tube and/or the bracket.

17 IGNITION SYSTEM

Ignitor - Refer to figure 11a and locate the ignitor. Disconnect the wire; remove the screw and the ignitor. Clean the ignitor assembly with an emery cloth.

Spark gap must be maintained to 3 mm. See FIGURE 16a.

Important : When reassembling, the wire must remain attached to the ignitor.

Figure 16a

Ignitor showing required spark gap measurement

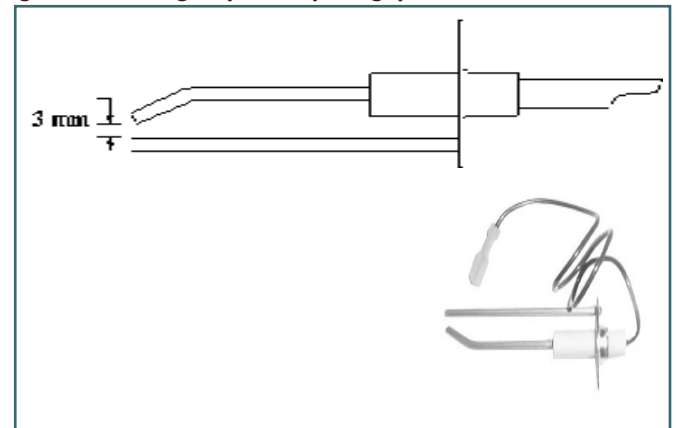
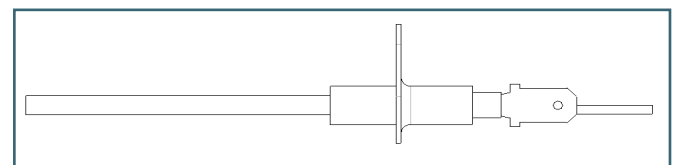

Figure 16b

Flame sensor



Caution :

Due to high voltage on the spark wire and electrode, do **not** touch when energized.

Flame sensor - Refer to figure 11a and locate the flame sensor. Disconnect the wire, remove the screw and the flame sensor. Clean with an emery cloth..

Control relay - See figure 17. The electronic burner relay monitors the operation of the heater including ignition. Do not open the control relay. Each heating season check the lead wires for insulation deterioration and good connections.

Proper operation of the direct spark ignition system requires a minimum flame signal of 1.0 microamps (DC) as measured by a microammeter.

For further information and check out procedure on the direct spark ignition system, refer to section 12 and the Troubleshooting Flow Chart in section 25.

Figure 17 - Control relay Brahma TC340A



18 Blower motor

The blower motor is equipped with thermal overload protection of the automatic reset type. Should the motor fail to run, it may be because of improper voltage characteristics. Make certain that the correct voltage is available at the motor.

19 Centrifugal fan

Remove dirt and grease from the motor and the blower wheel. Use care when cleaning the wheel to prevent causing misalignment or imbalance.

Follow these instructions for replacement of the direct driven centrifugal fan.

1. If the heater is installed, turn off the gas and disconnect the electric power.
2. Open the connection box on the blower and disconnect the fan motor wires.
3. Remove the blower.
4. Position the new blower on the heater.
5. Reconnect the fan motor wires according to the wiring diagram and close the connection box on the blower.
6. Restore power to the heater and turn on the gas. Light, following the instructions on the lighting instruction plate. Check for proper operation.

20 VENTER MOTOR & WHEEL

Remove dirt and grease from the motor casing, the venter housing, and the venter wheel. Venter motor bearings are permanently lubricated.

Follow these instructions for replacement of the venter motor and wheel assembly. Keep all hardware removed to be used in reassembling and installing the replacement parts.

1. Turn off the gas and disconnect the electric power.
2. Open the control compartment access door.
3. Disconnect the three venter motor wires at the control relay and ground screw (located on the control panel).
4. Holding the motor, remove the screws that attach the motor plate to the venter housing. Remove the motor and wheel assembly from the heater.
5. Reassemble with the replacement venter motor and wheel assembly.
6. Follow the wiring diagram to properly connect the wires.
7. Restore power to the heater and turn on the gas. Light, following the instructions on the lighting instruction plate. Check for proper operation. Replace the access door.

Venter wheel position on shaft

Figure 18a

UDSBD-4E mod. 015 - 020

(Rotation clockwise from motor shaft end)

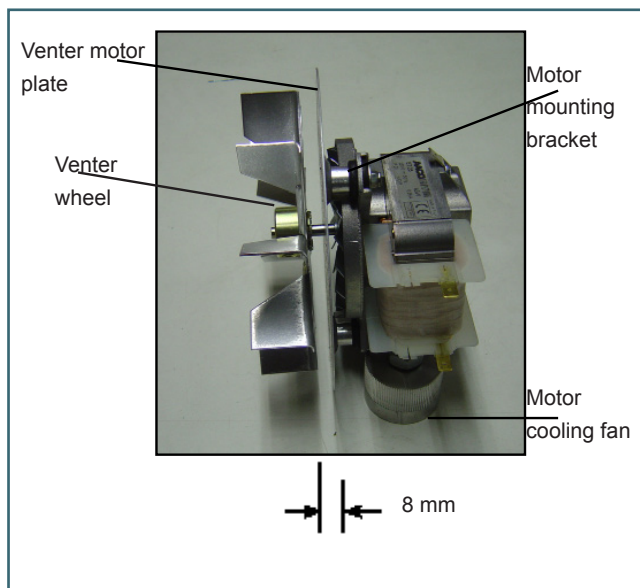

Figure 18b

UDSBD-4E mod. 025 - 030

(Rotation clockwise from motor shaft end)

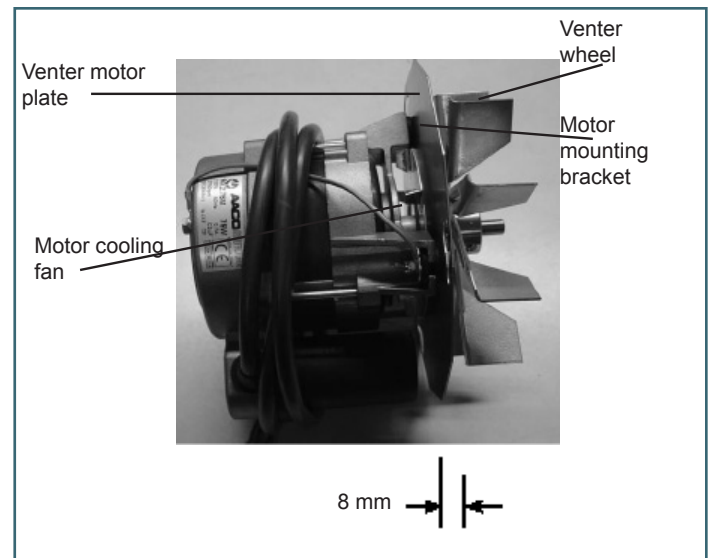
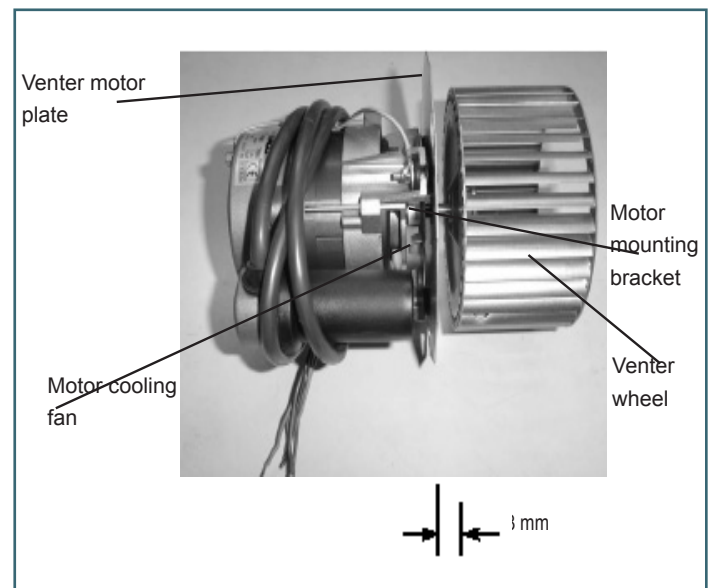

Figure 18c

UDSBD-4E mod. 035 - 064

(Rotation counter clockwise from motor shaft end)



21 OPERATING GAS VALVE

The main operating quick opening gas valve is powered through the thermostat and safety controls. The main control valve is of the diaphragm type providing regulated gas flow and is preset at the factory. The gas valve requires no field maintenance except careful removal of external dirt accumulation and checking of wiring connections. Instructions for testing pressure settings are in section 12.

Warning:

The operating valve is the prime safety shutoff. All gas supply lines must be free of dirt or scale before connecting to the unit to ensure correct sealing.

22 COMBUSTION AIR PRESSURE SWITCH

DANGER

Safe operation of this unit requires proper venting flow. Never bypass the combustion air pressure switch or attempt to operate the unit without the venter operating.

The combustion air pressure switch ensures that proper combustion airflow is available. The switch senses the differential pressure between the negative pressure in the flue gas collector box and the pressure in the control section.

On startup when the heater is cold, the sensing pressure is at the most negative level, and as the heater and flue system warm up, the sensing pressure becomes less negative.

If a restriction or excessive flue pipe length causes the sensing pressure to be below the allowable level, the pressure switch will shut off the main burner.

If it is determined that the pressure switch needs replacing, use only the factory-authorized replacement part that is designed for the model and size of heater being serviced.

Figure 19



23 LIMIT CONTROLS

All units are equipped with temperature activated limit controls. The controls are factory set and non-adjustable. If either set-point is reached, the corresponding limit control will interrupt the electric power to the gas valve. These safety devices provide protection in the case of motor failure or lack of airflow due to restrictions. (For locations, see figure 11a.)

If a limit control needs replacing, use only the factory authorized replacement part for the size of heater.

For approximate limit locations, see figure 11a.

Warning :

Never bypass the limit controls, hazardous conditions could result.

Figure 20 : LC1

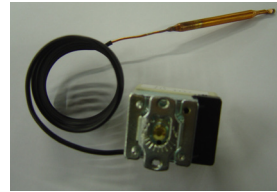
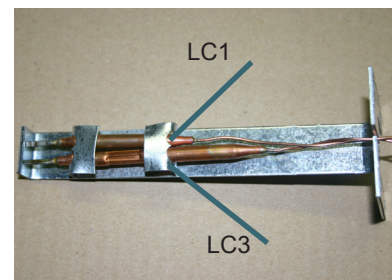

Figure 21 : LC3



Figure 22 : Location LC1/LC3



24 FLUE & COMBUSTION AIR PIPING

Check the complete system at least once a year. Inspection should include all joints, seams, concentric adapters and the flue terminal cap. Replace any defective or heavily corroded parts.

The integrated control relay monitors the operation of the heater. If the heater fails to operate properly, review the flow chart below and see the operating sequence in section 16.

The general troubleshooting charts on the following pages will also help you to determine the problem.

1/ Air heater does not operate and lock-out indicator light is off

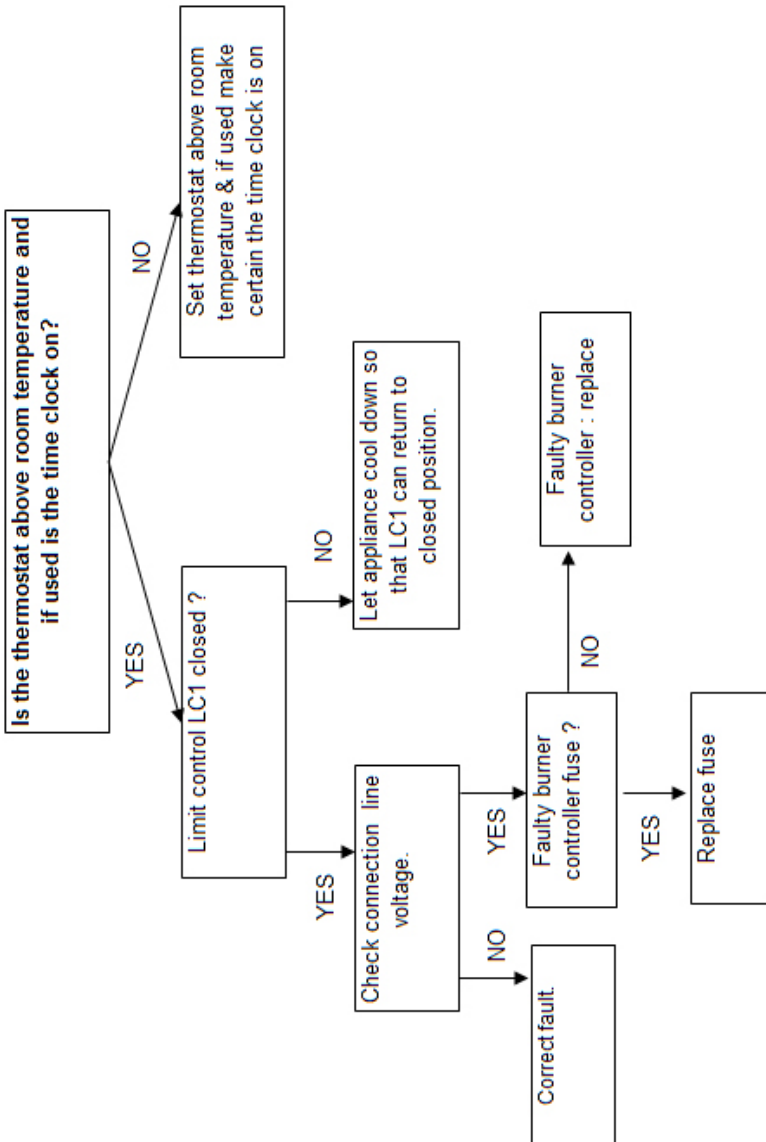

2/ Air heater does not operate and lock-out indicator light is on

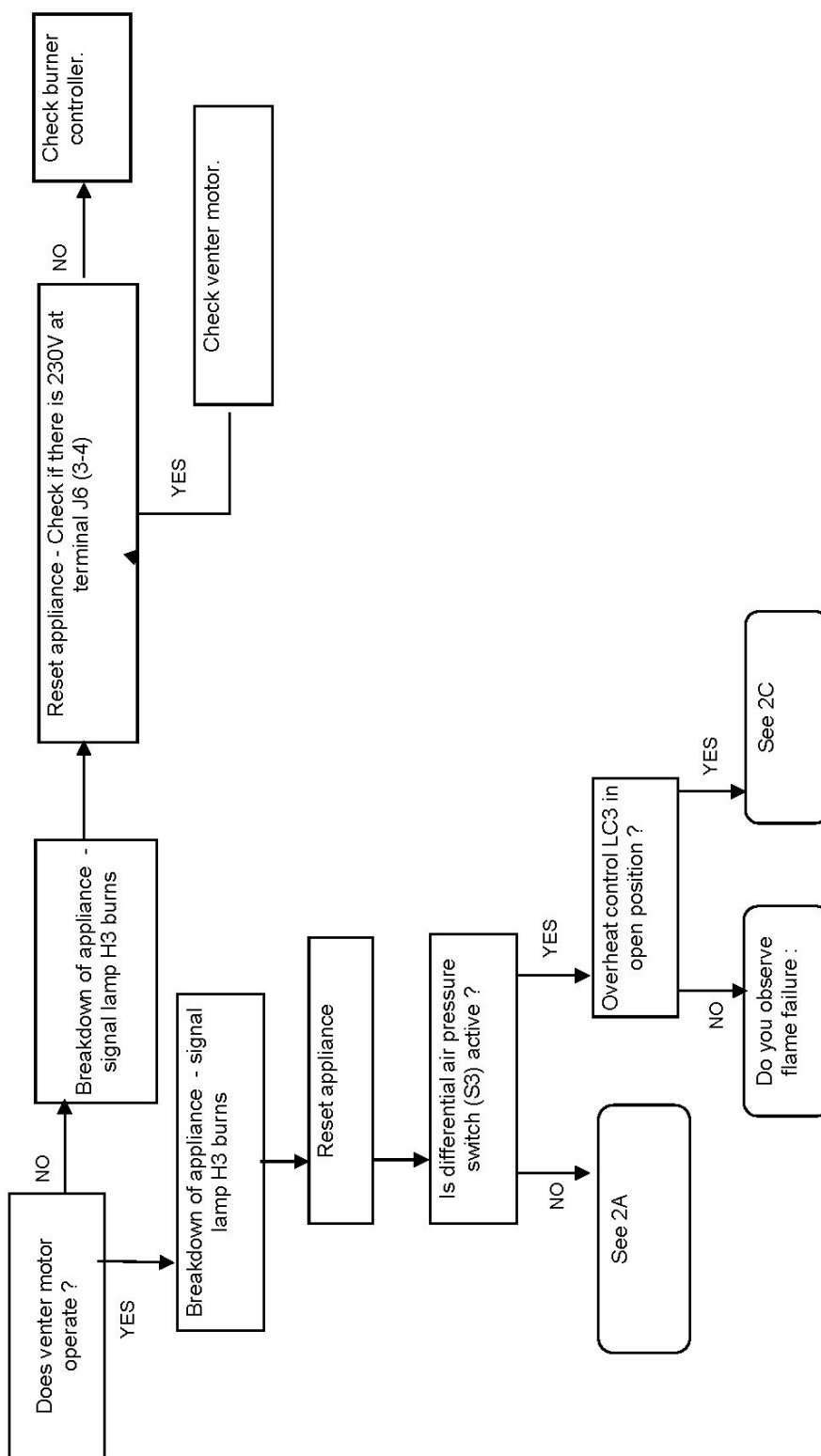

2A : Faulty differential air pressure switch

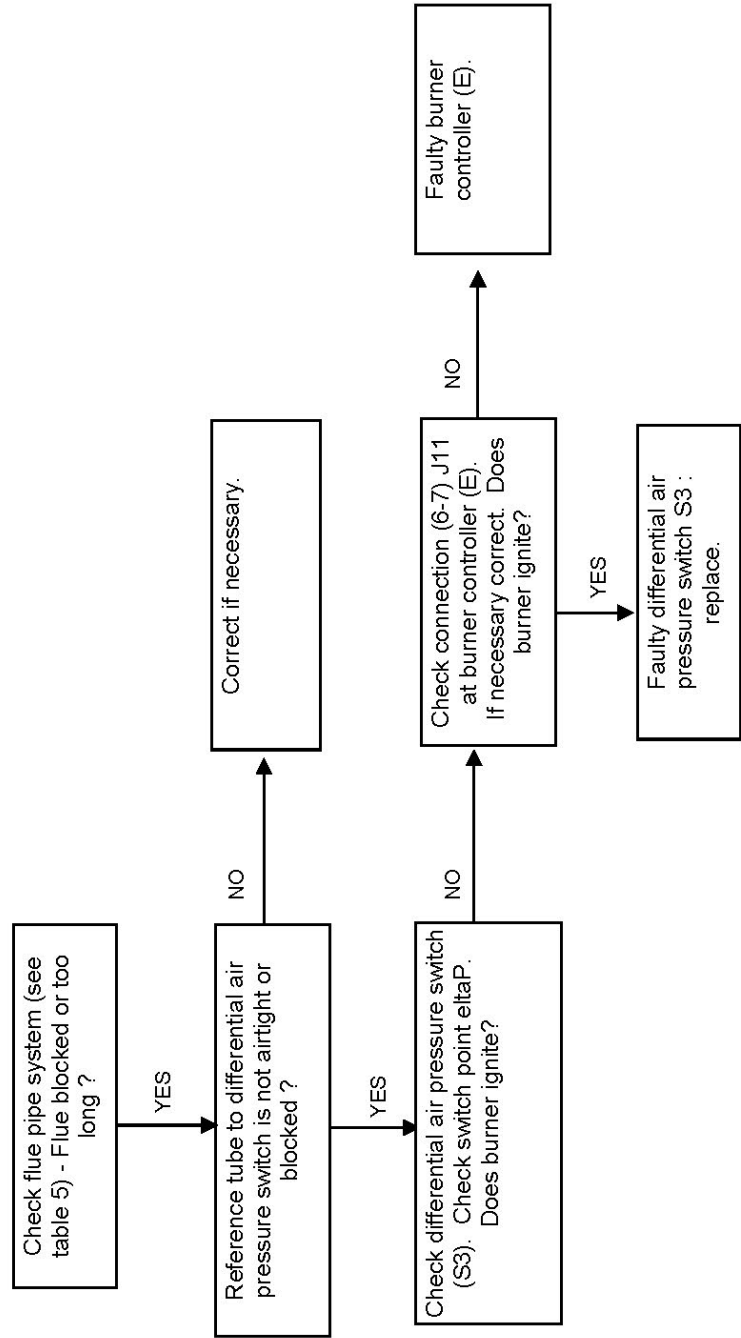

2C : Limit controls LC1 (auto reset) & LC3 (manual reset) switch burner off

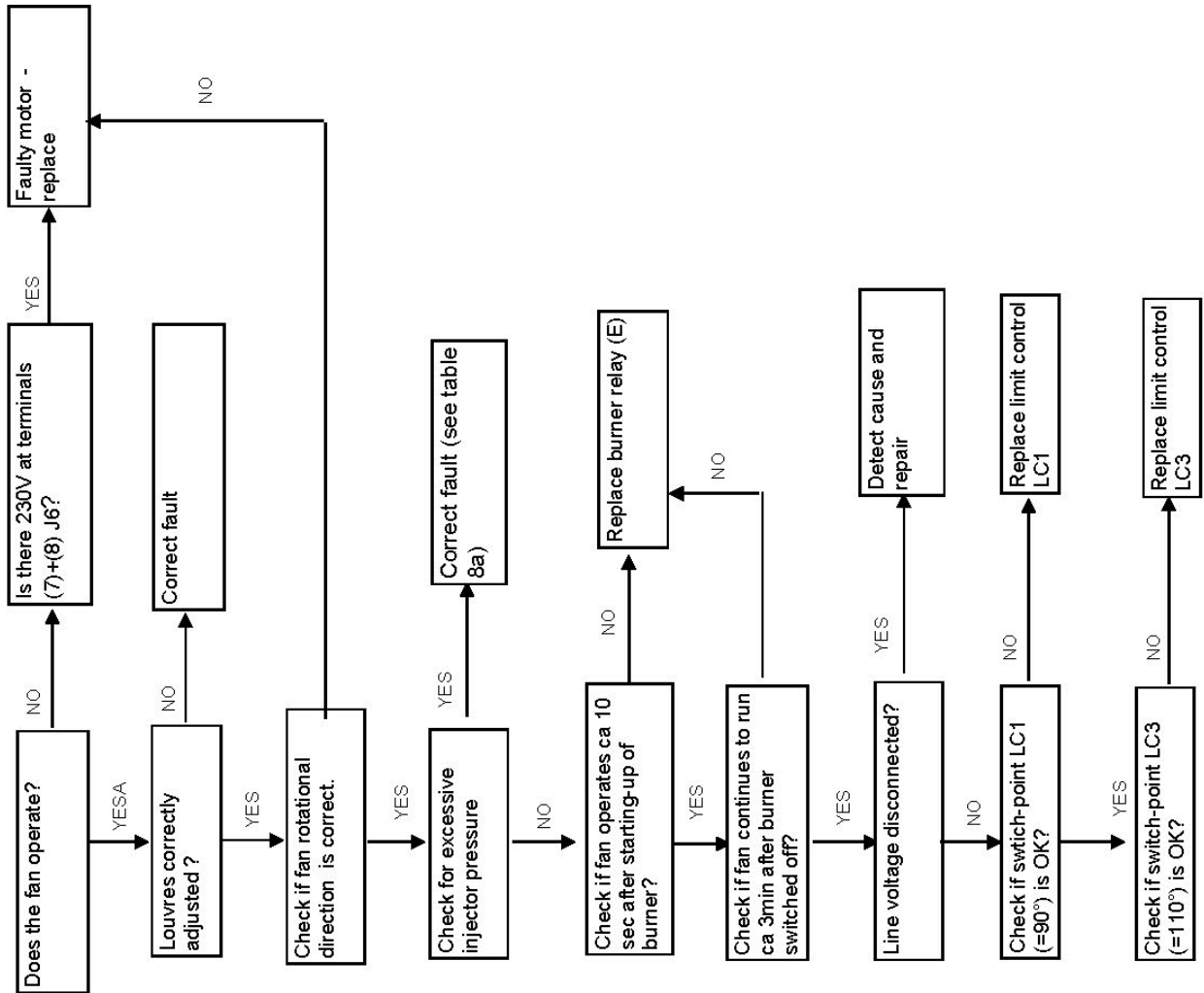

General troubleshooting

PROBLEM	PROBABLE CAUSE	REMEDY
Venter motor will not start	<ol style="list-style-type: none"> 1. No power to unit 2. No power to venter motor 3. Integrated burner relay defective. 4. Defective venter motor. 5. Fluse blown (F3.1). 6. Fuse burner relay blown. 7. LC1 open. 8. LC3 open. 9. Unit in lock-out. 10. Room thermostat open. 	<ol style="list-style-type: none"> 1. Turn on power, check supply fuses or circuit breaker. 2. Check connections at burner relay and/or venter motor terminals. 3. Replace burner relay. 4. Replace venter motor. See Section 26. 5. Replace fuse. 6. Replace fuse. 7. a) Set heater on ventilation until LC1 closes. b) Replace LC1. c) Check if there is obstruction at the fan side. 8. a) Reset LC3. b) Replace LC3. 9. Push on reset button. 10. Set thermostat above room temperature.
Burner will not light	<ol style="list-style-type: none"> 1. Main valve not operating 2. Air in the gas line. 3. Gas pressure too high or too low. 4. No spark: <ol style="list-style-type: none"> a) Loose wire connections. b) Incorrect spark gap. c) Spark cable has a short circuit to ground. d) Spark electrode has a short circuit to ground. e) Burner relay not grounded. f) Unit not properly grounded. g) Faulty burner relay. 5. Combustion air pressure switch not closing upon power to venter. 	<ol style="list-style-type: none"> 1. a) Check voltage on valve during ignition period. b) Check connector on main gas valve. c) Check connector on burner relay. d) Replace valve. 2. Purge gas line. 3. a) Supply pressure should be 15 mbar for natural gas (UK only) or 37 mbar for propane gas (UK only). b) Obstruction in the gas line. c) Gas line connection diameter too small. 4. Check the following: <ol style="list-style-type: none"> a) Be certain all wire connections are solid. b) Maintain spark gap at 3 mm. c) Replace worn or grounded spark cable. d) Replace if ceramic spark electrode is cracked or grounded. e) Check burner relay ground wire. f) Make certain unit is properly field grounded (earthed) and properly phased (L1 to hot lead, L2 to neutral). g) If voltage is available to the burner relay and all other causes have been eliminated, replace burner relay. 5. First check the following: <ol style="list-style-type: none"> a) Make sure unit is properly vented. b) Remove obstructions from vent. c) Replace faulty tubing to pressure switch. d) Replace faulty pressure switch.
Burner cycle on and off	<ol style="list-style-type: none"> 1. Gas pressure too high or too low. 2. Burner relay not grounded. 3. Faulty burner relay. 4. Flame sensor grounded. 5. Cracked ceramic at sensor. 6. Incorrect polarity. 	<ol style="list-style-type: none"> 1. Supply pressure should be 15 mbar for natural gas (UK only) or 37 mbar for propane gas (UK only). 2. Check burner relay ground wire connection. 3. If (220/240) volts is available to the burner relay and all other causes have been eliminated, replace burner relay. 4. Be certain flame sensor lead is not grounded or insulation or ceramic is not cracked. Replace as required. 5. Replace sensor. 6. Check polarity switch and if necessary reverse line voltage wires to terminal block connections.
Blower will not run	<ol style="list-style-type: none"> 1. Circuit open. 2. Defective time delay relay for the fan (KFC). 3. Defective motor. 	<ol style="list-style-type: none"> 1. Check wiring and connections. 2. a) Replace the time delay relay. b) Check voltage on anticipation resistor when gas valve is open. 3. Replace blower & motor.
Blower or venter motor turns on and off while burner is operating	<ol style="list-style-type: none"> 1. Motor internal thermal protection device cycling on and off. 	<ol style="list-style-type: none"> 1. Check motor load against motor rating plate. Replace motor if needed.
Venter motor turns off in case of thermal overload	<ol style="list-style-type: none"> 1. Electrical current too high or too low 2. Motor defect 3. Air flow insufficient 4. Faulty bearing 	<ol style="list-style-type: none"> 1. Correct 2. Replace motor 3. Clean motor, venter & filter 4. Oil bearing or replace motor

Description	Application UDSBD-4E	Partnumber
Control relay	UDSBD015 ... 064	03 25321
Spark ignitor	UDSBD015 ... 064	05 25162
Flame sensor	UDSBD015 ... 064	03 401US 195292
Limit control LC3	UDSBD015 ... 064	03 24959 03
Limit control LC1	UDSBD015 ... 064	03 24959 04
Pressure switch	UDSBD015/020/025/050/055/064	30 60621 120
Pressure switch	UDSBD 030	30 60621 100
Pressure switch	UDSBD 035-043	30 60621 94
Burner-on indication lamp	UDSBD015 ... 064	60 61997
Reset switch	UDSBD015 ... 064	60 61998
gas valve nat gas 2st.	UDSBD015.....043	03 25141 P
gas valve prop 2st.	UDSBD015.....043	03 25141 P337
gas valve nat gas modureg	UDSBD015.....043	03 25140 M
gas valve prop modureg	UDSBD015.....043	03 25140 M
gas valve nat gas 2st.	UDSBD050.....064	03 25136 02
gas valve prop 2st.	UDSBD050.....064	03 35136 P437
gas valve nat gas modureg	UDSBD050.....064	03 25136 M
gas valve prop modureg	UDSBD050.....064	03 25136 M
Venter motor	UDSBD015 ... 020	11 43430 01
Venter motor	UDSBD025 ... 064	11 43426 04
Venter assembly	UDSBD015 ... 020	35 25218
Venter assembly	UDSBD025 ... 030	35 25222
Venter assembly	UDSBD035 ... 064	35 25223
Venter wheel assy	UDSBD015 ... 020	90 82242
Venter wheel assy	UDSBD025 ... 030	90 82244
Venter wheel	UDSBD035 ... 064	02 25728
Direct driven blower DD 9/7	UDSBD015 ... 020	01 27211
Direct driven blower DD 10/10	UDSBD025 ... 030	01 27210
Direct driven blower DD 12/12	UDSBD035 ... 064	02 26012 035064
Main wiring assy	UDSBD015 ... 064	06 41852

CERTIFICATE

**EC DECLARATION OF CONFORMITY OF MACHINERY
(Annex II 1 A of EC Machinery Directive 2006/42/EC)**

**Nortek Global HVAC Belgium nv
J&M Sabbestraat 130/A000
B-8930 Menen, Belgium**

**Hereby declares that the following gas-fired unit heaters:
UDSBD-4E
Types 015, 020, 025, 030, 035, 043, 050, 055, 064
Complies with the requirements of the above mentioned machinery directive**

**Complies with the requirements of further directives, namely
GAD 2009/142/EC - EMC 2014/30/EU – LVD 2014/35/EU**

**The following harmonized standards have been applied:
EN 1020: Non-domestic gas-fired forced convection air heaters for space heating
not exceeding a net heat input of 300 kW, incorporating a fan to assist transporta-
tion of combustion air and/or combustion products.**

**The following notified body
Technigas
Chaussée de Vilvorde 156
BE 1120 Brussels
has been involved with regarding to the
EC type examination number E0827/5331
Menen, 31.01.2018**



**J. Dubus
Engineering Team Leader**

NORTEK GLOBAL HVAC Belgium nv
J&M Sabbestraat 130/A000
B-8930 Menen, Belgium

Tel +32(0)56 52 95 11
www.reznor.eu

