

Nortek Global HVAC, LLC

Multi Variable Heat Pump Duct Type Indoor Unit

Owner's Manual Heat Pump

Models:

BDDH-5.6(18)SAK

BDDH-7.1(24)SAK

BDDH-9.0(30)SAK

BDDH-11.2(36)SAK



BDDH-12.5(42)SAK

BDDH-14.0(48)SAK

- Please read this owner's manual carefully before operation and retain it for future reference
- Specifications & illustrations subject to change without notice or incurring obligations

Preface

For correct installation and operation, please read all instructions carefully. Before reading the instructions, please be aware of the following items:

 WARNING	DANGER: Failure to comply may result in severe personal injury, property damage and/or death.
 CAUTION	CAUTION: Failure to comply may result in personal injury and/or property damage
 NOTICE	NOTICE is used to address practices not related to personal injury.

WARNING

- (1) Instructions for installation and use of this product are provided by the manufacturer.
- (2) Installation must be performed in accordance with the requirements of NEC and CEC by authorized personnel only.
- (3) For the safe operation of this unit, please read and follow the instructions carefully.
- (4) During operation, total capacity of indoor units should not exceed the total capacity of outdoor units, otherwise, poor cooling or heating performance may result.
- (5) Direct operators or maintainers should keep this manual for future reference.
- (6) If this unit fails to operate normally, please contact a qualified contractor as soon as possible and provide the following information:
 - 1) Content on the nameplate (model number, cooling capacity, serial number and manufacture date).
 - 2) Malfunction details (before and after the malfunction occurred).
- (7) Each unit has been strictly tested and proved before shipment. In order to prevent units from being damaged or malfunctioning because of improper service, please do not disassemble the unit by yourself. If you need maintenance or service, please contact a qualified contractor.
- (8) Installation must be performed in accordance with the requirements of NEC and CEC by authorized personnel only.

User Notice

- This appliance is not intended for use by persons (including children) with reduced physical, sensory or mental capabilities, or lack of experience and knowledge.
- **DISPOSAL:** Do not dispose this product as unsorted household waste. Please dispose or recycle responsibly.



Contents

1 Safety Precautions.....	1
2 Product Introduction.....	2
2.1 Names of Key Components	2
2.2 Rated Working Condition.....	2
2.3 Unit Functions.....	2
3 Installation Preparation.....	3
3.1 Standard Fittings	3
3.2 Selecting a Location for Installation	4
3.3 Requirements for Communication Line	5
3.3.1 Select communication line for indoor unit and wired controller	5
3.3.2 Select communication line for indoor unit and outdoor unit	5
3.4 Wiring Requirements.....	6
4 Installation Instructions.....	6
4.1 Installation of Indoor Unit.....	6
4.1.1 Dimensions.....	6
4.2 Refrigerant Pipe Connection	9
4.3 Drainage Pipe Installation and Drainage System Testing.....	9
4.3.1 Notice for Installation of Drain Pipe.....	9
4.3.2 Drainage pipe installation	9
4.3.3 Test of Drainage System.....	11
4.4 Installation of Air Duct.....	12
4.4.1 Installation of Air-out Duct.....	12
4.4.2 Shape and Size of Air Outlet and Air-return Opening	13
4.4.3 Installation of the Return Air Duct.....	13
4.5 Installation of Wired Controller.....	14
5 Wiring Work	14
5.1 Connection of Wire and Patch Board Terminal	15
5.2 Power Cord Connection.....	15
5.3 Connection of Communication Wire between Indoor Unit and Outdoor Unit (or indoor unit)	16
5.4 Connect Communication Wire of Wired Controller	16
5.5 Connection of Wired Controller and Indoor Units Network.....	17
6 Routine Maintenance	19
6.1 Cleaning of Filter	19
6.2 Preseason Maintenance	19
6.3 Post-SeasonalMaintenance	19
7 Table of Error Codes for Indoor Unit.....	20
8 Troubleshooting	20

1 Safety Precautions

 WARNING
(1) Follow this instruction to complete the installation work. Please read this manual carefully before unit startup and service.
(2) Wire size of power cord should be sized correctly. The damaged power cord and connection wire should be replaced by specialized cable.
(3) After connecting the power cord, please affix the electric box cover properly.
(4) Never fail to comply with the nitrogen charge requirements. Charge nitrogen when welding pipes.
(5) Never short-circuit or cancel the pressure switch to prevent unit damage.
(6) Connect the wired controller before energization; otherwise wired controller could be damaged.
(7) Before using the unit, please check if the piping and wiring are correct to avoid water leakage, refrigerant leakage, electric shock, or fire etc..
(8) Do not insert fingers or objects into air outlet/inlet grille.
(9) Open the door and window and keep good ventilation in the room to avoid oxygen deficit when the gas/oil heating equipment is used.
(10) Never start up or shut off the air conditioner by plugging or unplugging the power cord.
(11) Let the unit run for at least five minutes after startup; otherwise it will affect oil return of the compressor.
(12) Do not allow children operate this unit.
(13) Do not operate this unit with wet hands.
(14) Turn off the unit or cut off the power supply before cleaning, otherwise electric shock or injury may occur.
(15) Never spray or flush water towards unit, otherwise malfunction or electric shock may occur.
(16) Do not expose the unit to the wet or corrosive conditions.
(17) Under cooling mode, please don't set the room temperature too low. Keep the temperature difference between indoor and outdoor unit within 5°C(9°F).
(18) User is not allowed to repair the unit. Faulty service may cause electric shock or fire. Please contact a qualified service technician for help.
(19) Before installation, please check if the power supply matches the requirements specified on the nameplate.
(20) Installation should be conducted by dealer or qualified personnel. Please do not attempt to install the unit yourself. Faulty installation may result in water leakage, electric shock or fire etc.
(21) Be sure to use the appropriate accessories and parts to prevent the water leakage, electric shock and fire.
(22) Make sure the unit can be grounded properly and securely to avoid electric shock. Please do not connect the ground wire to gas pipe, water pipe, lightning rod or telephone line.
(23) Connect power to the unit 8 hours before operation. Do not cut off the power when it will not be used for a short period of time, i.e. overnight (to protect the compressor).
(24) If refrigerant leakage occurs during installation, please ventilate immediately. Toxic gas will result if the refrigerant gas meets spark or open flame.
(25) Volatile liquid, such as paint thinner or gasoline will damage the unit appearance. Only use soft cloth with a little mild detergent to clean the outer casing of unit.
(26) If anything abnormal occurs (such as burning smell), please power off the unit and cut off the main power supply, and then immediately contact a licensed contractor. If the problem persists, the unit might be damaged and lead to electric shock or fire.

Manufacturer will not assume responsibility for any personal injury or property loss caused by improper installation, improper debugging, unnecessary repair or not following the instructions of this manual.

2 Product Introduction

2.1 Names of Key Components

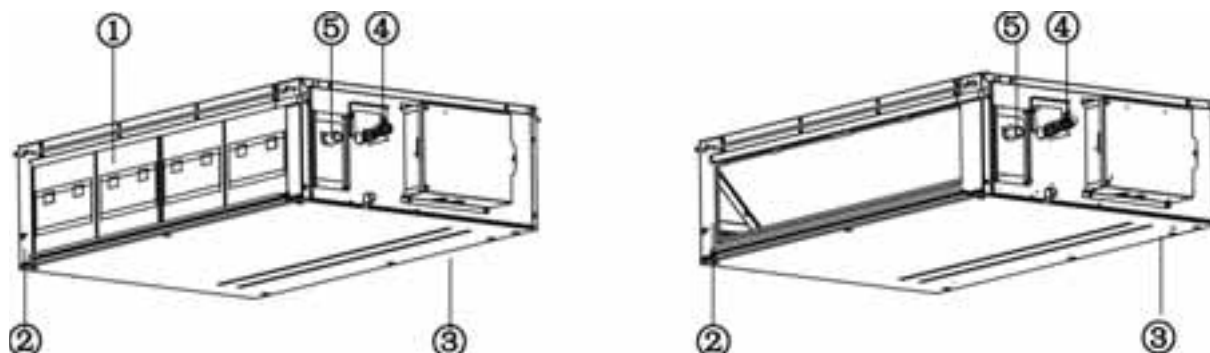

No.	①	②	③	④	⑤
Name	Filter	Air Inlet	Air Outlet	Fittings	Drain Pipe

2.2 Rated Working Condition

	Indoor Side Condition		Outdoor Side Condition	
	Dry Bulb Temp°C(°F)	Wet Bulb Temp°C(°F)	Dry Bulb Temp°C(°F)	Wet Bulb Temp°C(°F)
Rated Cooling	27(80.6)	19(66.2)	35(95)	24(75.2)
Rated Heating	20(68.0)	15(59.0)	7(44.6)	6(42.8)

Indoor Unit Working Temperature Range: 16 ~ 32°C (61~90°F).

2.3 Unit Functions

Unit Functions	Wired Controller WRC1(Standard)	Remote Controller RC (Optional)
Operation Mode (Cooling, Heating, Fan, Dehumidifying)	✓	✓
Fan Speed Adjustment	✓	✓
Temperature Adjustment	✓	✓
X-fan Function	✓	✓
Quiet Function	✓	✗
Sleep Function	✓	✓
Save Function	✓	✗
E-heater Function	✗	✗
Memory Function	✓	✗
Absence Function	✓	✓
Timer Function	✓	✓
Low Temp Dehumidify Function	✓	✗

Multi Variable Heat Pump Duct Type Indoor Unit

Filter Cleaning Reminder Function	✓	✗
I Feel	✗	✓
Light Function	✓	✓
Swing	✓	✓

Note!









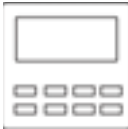

- ① ✓: included, ✗: not included
- ② Please refer to the user manual of Wired Controller or Remote Controller for more details



3 Installation Preparation

Note: Product illustrations are for reference only. Please refer to actual products. Unspecified measure unit is mm/inch.

3.1 Standard Fittings

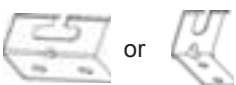
Please use the supplied standard fittings listed below as instructed.

No.	Name	Illustration	Q'ty	Usage
1	Wired Controller		1	To control the indoor unit
2	M4X25 Screw (Cross recessed small pan head screw)		3	To mount the wired controller
3	Drain Hose Assembly		1	To connect with the hard PVC drain pipe
4	Special Nut		1	To be used for connecting the refrigerant pipe
5	M10X8 Nut with Washer		4	To be used with the hanger bolt for installing the unit.
6	M10 Nut (M10X8.4 Nut)		4	To be used with the hanger bolt for installing the unit.
7	M10 Washer (Spring Washer M10X2.6)		4	To be used with the hanger bolt for installing the unit.
8	Insulation		1	To insulate the gas pipe
9	Insulation		1	To insulate the liquid pipe
10	Fastener		8	To fasten the sponge
11	Hanger		4	To fix the indoor unit

12	Nut with Washer		8	To fix the hook on the cabinet of the unit.
13	paper pattern for installation (cardboard template)		1	Locate the drill hole on ceiling

3.2 Selecting a Location for Installation

- (1) The appliance shall not be installed in the laundry.
- (2) The supporting structure to be used must have a sufficient load carrying capacity to support the weight of the unit.
- (3) Drain pipe can drain water out easily.
- (4) There is no obstacle at inlet or outlet that might impede good air circulation.
- (5) There should be sufficient space around the unit for maintenance access. Please see diagram below.
- (6) Keep the unit away from other heat sources, inflammable gas and smoke.
- (7) This is a concealed ceiling type unit.
- (8) Indoor unit, outdoor unit, power cord and electric wire should stay at least 1m (40 inch) from the TV set and radio. Electrical appliances may cause electromagnetic interference. (Strong electromagnetic field will require clearances more than 1m (40 in.)

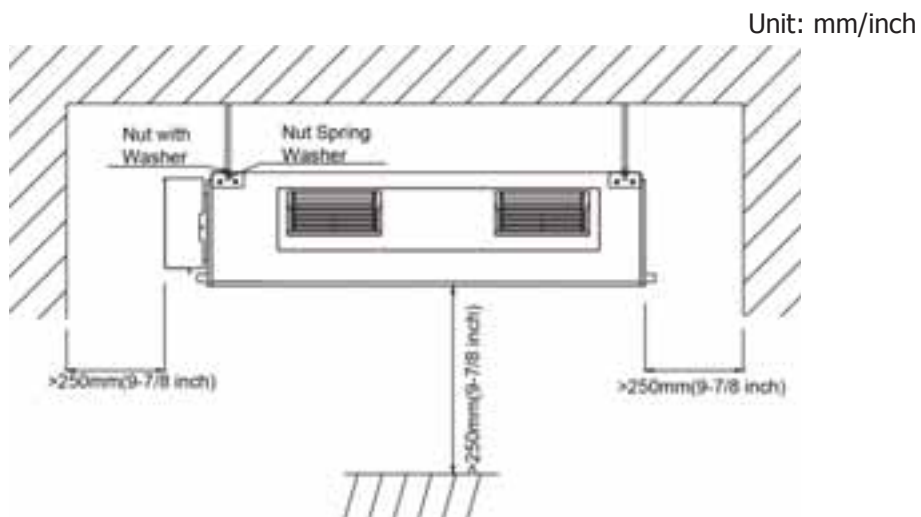

Fig 3.2

NOTICE

(1) Installation of the unit must be in accordance with National Electric Codes and local regulations.

(2) Improper installation will affect unit's performance, so do not install the unit yourself. Please contact local dealer to arrange professional technicians for the installation.

(3) Do not connect power until all installation work is finished.

3.3 Requirements for Communication Line

Note:

If the unit is installed in or near a strong electromagnetic field, shielded wire must be used for the communication wire between indoor unit and controller. Twisted pair line with shielding function must be used for the communication wire between indoor units and indoor unit (outdoor unit).

3.3.1 Select communication line for indoor unit and wired controller

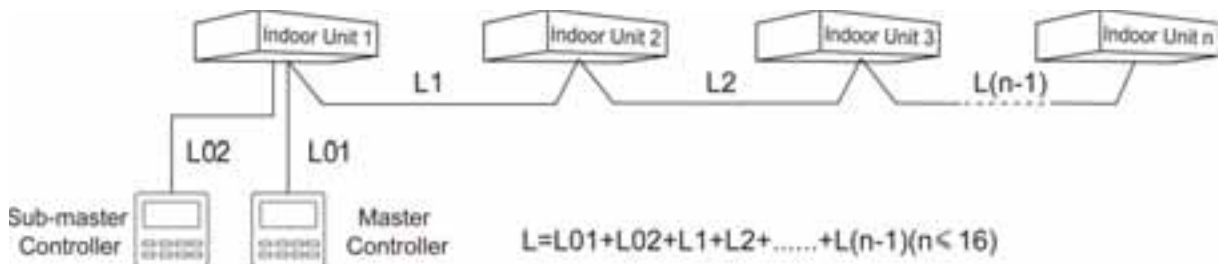

Fig 3.3.1

Wire type	Total length of communication wire between indoor unit and wired controller (m/feet)	Wire diameter (AWG)	Wire standard	Remark
Light/Ordinary polyvinyl chloride sheathed cord. (60227 IEC 52/60227 IEC 53)	$L \leq 250(850)$	2×18~2×16	IEC 60227-5:2007	1. Total length of communication cable can't exceed 250m (820 feet). 2. The cord shall be Circular cord (the cords shall be twisted together). 3. If unit is installed in or near an strong magnetic field use shielded wire.

3.3.2 Select communication line for indoor unit and outdoor unit

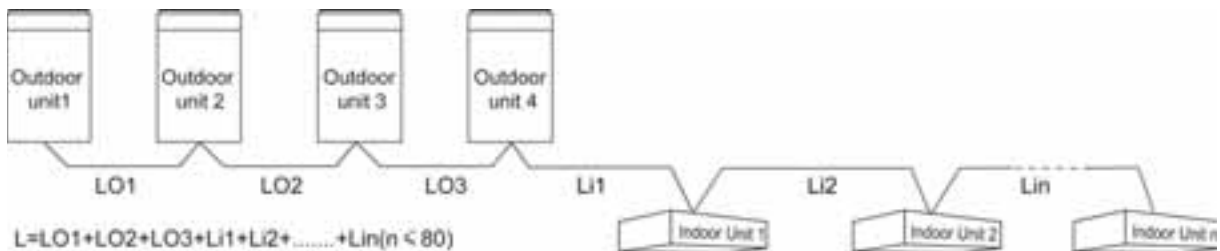

Fig 3.3.2

Wire type	Total length of communication wire between indoor unit and indoor unit(outdoor unit) (m/feet)	Wire diameter (AWG)	Wire standard	Remark
Light/Ordinary polyvinyl chloride sheathed cord. (60227 IEC 52 /60227 IEC 53)	$L \leq 1000(3280)$	$\geq 2 \times 18$	IIEC 60227-5:2007	1. If the wire diameter is enlarged to 18AWG, the total communication cable length can reach 1500m(4920 feet). 2. The cord shall be Circular cord (the cords shall be twisted together).

				3. If unit is installed in or near strong magnetic field use shielded wire.
--	--	--	--	---

3.4 Wiring Requirements

(1) Power Cord Size and Air Switch Capacity

Model	Power Supply	MCA(A)	MOP(A)
BDDH-5.6(18)SAK	208~230V-1ph-60Hz	0.75	1.35
BDDH-7.1(24)SAK		0.75	1.35
BDDH-9.0(30)SAK		1.25	2.25
BDDH-11.2(36)SAK		1.25	2.25
BDDH-12.5(42)SAK		1.25	2.25
BDDH-14.0(48)SAK		1.25	2.25

NOTICE

(1) Use copper wire only as unit's power cord. Operating temperature should be within its rated value.

(2) If the power cord is more than 15 m (50feet) long, proportionally increase the sectional area of power cord to avoid overload.

(3) Above selection requirements: Power cord size is based on BV single-core wire (2~4pc) at 40° (104°F) ambient temperature when laying across plastic pipe. Air switch is D type and used at 40°C (104°F). If actual installation condition varies, please lower the capacity according to the specifications of power cord and air switch provided by manufacturer.

(4) Install cut-off device near the unit. The minimum distance between each stage of cut-off device should be 3 mm (1/8 inch) (The same for both indoor unit and outdoor unit).

4 Installation Instructions

4.1 Installation of Indoor Unit

4.1.1 Dimensions

Equip with an inspection hatch after lifting the unit. For the convenience of maintenance, the service port should be on one side of the electric box and below unit's lower level.

(1) Below are the outline dimension applicable to indoor units

Multi Variable Heat Pump Duct Type Indoor Unit

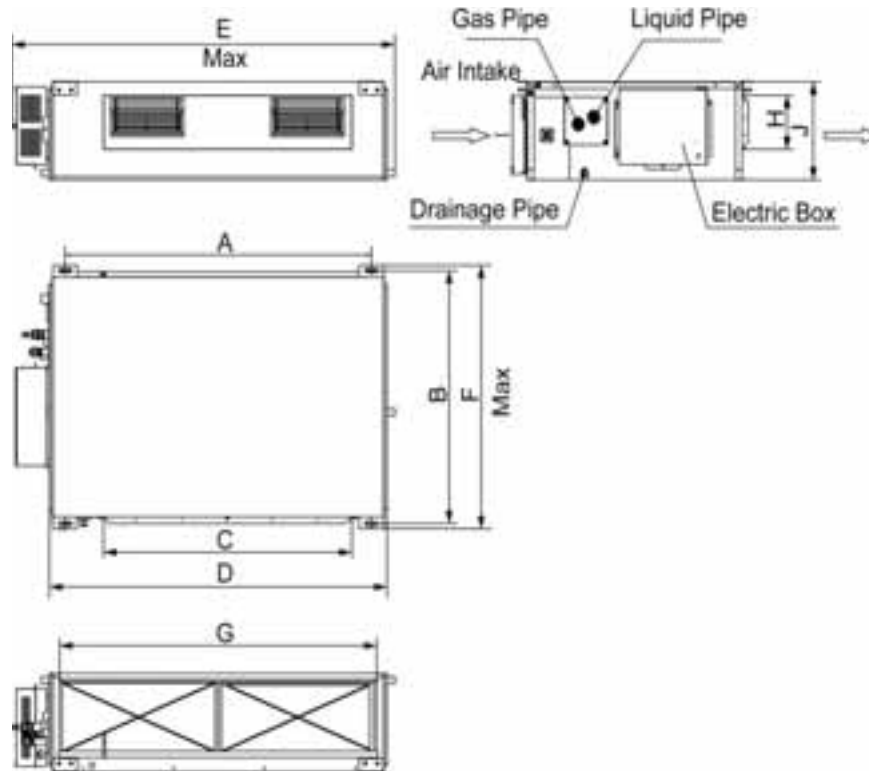

Fig 4.1.1

Below are dimensions of A, B, C, etc. for different models:

Unit: mm/inch

Model	A	B	C	D	E	F	G	H	I	J
BDDH-5.6(18)SAK	1101	517	820	1159	1271	558	1002	160	235	268
BDDH-7.1(24)SAK	(43-3/8)	(20-3/8)	(32-1/4)	(45-5/8)	(50)	(22)	(39-1/2)	(6-1/4)	(9-1/4)	(10-1/2)
BDDH-9.0(30)SAK										
BDDH-11.2(36)SAK										
BDDH-12.5(42)SAK	1101	748	820	1115	1229	775	979	160	231	290
BDDH-14.0(48)SAK	(43-3/8)	(29-1/2)	(32-1/4)	(43-7/8)	(48-3/8)	(30-1/2)	(38-1/2)	(6-1/4)	(9-1/8)	(11-3/8)

(2) Drill bolt holes and install bolts

- 1) Attach the cardboard template on the installation position. Drill 4 holes according to the hole site on the cardboard as shown in Fig. 4.1.3. The diameter of hole should match the diameter of expansion bolt and the depth is 60-70mm (2-3/8~2-3/4 inch), as shown in Fig. 4.1.4.

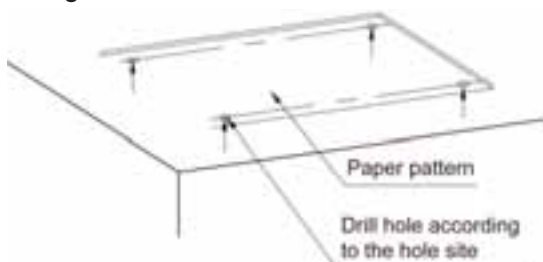

Fig 4.1.3

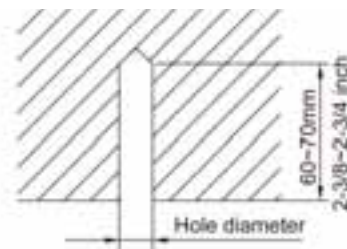

Fig 4.1.4

- 2) Insert the M10 expansion bolt into the hole and drive the nail into the bolt, as shown in Fig. 4.1.5.

Note:

The length of bolt depends on the installation height of the unit. Bolts are field supplied.

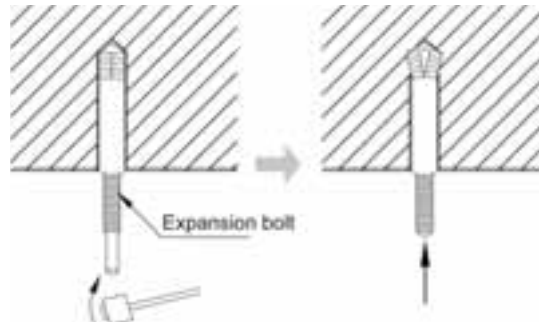

Fig 4.1.5

- (3) Install the indoor unit temporarily

Assemble suspension bolt on the expansion bolt. Attach the hanger bracket to the suspension bolt. Be sure to secure it by using a nut and washer on the upper and lower sides of the hanger bracket. The washer plate will prevent the washer from falling.

- (4) Using the cardboard template

Refer to cardboard template for ceiling opening dimension. The center of ceiling opening is indicated. Mount the template to the unit with 4 screws and secure the corners of the waterspout at the drainage pipe with screws.

- (5) Adjust the unit to the right position.

- (6) Make sure the unit is level

The indoor unit is equipped with a built-in water pump and float switch. Verify the unit is level.

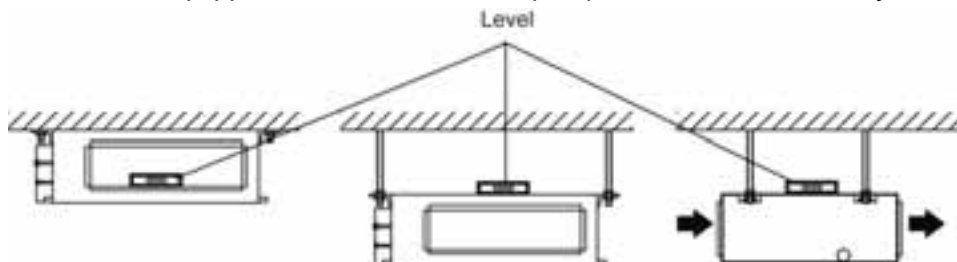

Fig 4.1.6

- (7) Remove the washer locating plate and then tighten the nut on it.

- (8) Remove the cardboard template.

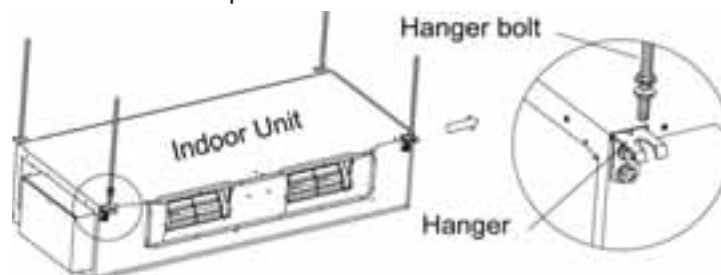

Fig 4.1.7

4.2 Refrigerant Pipe Connection

- (1) Align the flaring port of copper pipe to the center of screwed joint and then tighten the flaring nut by hand.
- (2) Tighten the flaring nut with torque wrench as shown in Fig. 4.2.

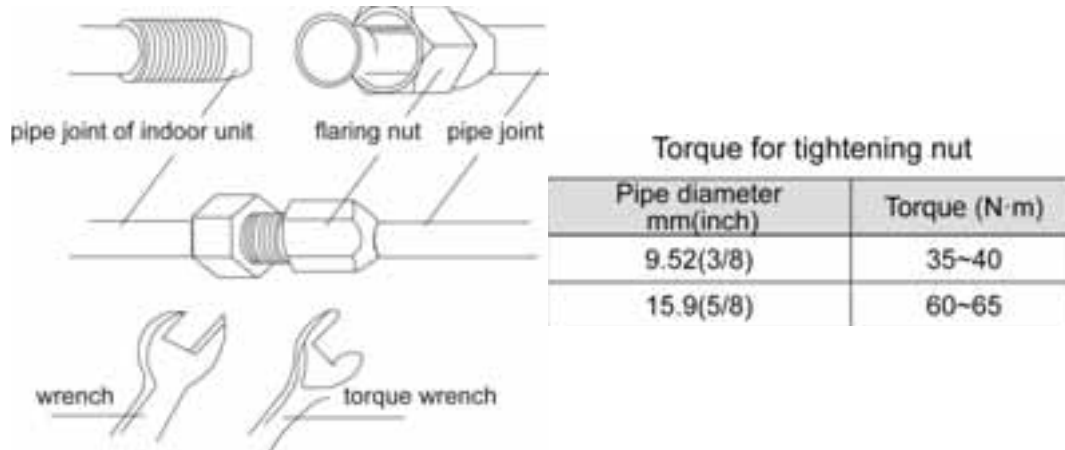

Fig.4.2

- (3) Use pipe bender when bending the pipe to avoid bending at too small of an angle.
- (4) Wrap the connection pipe and joint with sponge and then secure it with tape.

4.3 Drainage Pipe Installation and Drainage System Testing

4.3.1 Notice for Installation of Drain Pipe

- (1) The drainage pipe should be as short as possible. The downward slope should be at least 1%~2% in order to drain condensate water smoothly.
- (2) The diameter of drainage hose should be larger than or equal to the diameter of drainage pipe joint.
- (3) Install drainage pipe according to the following Fig. and apply insulation to the drainage pipe. Improper installation may lead to water leakage.
- (4) Normal hard PVC pipe can be used as the drainage pipe. During connection, insert the end of PVC pipe into the drainage hole and then tighten it with drainage hose and cable tie. Don't connect the drainage hose and drainage hole with glue.
- (5) When a drainage pipeline are used for several units, the position of pipeline should be about 100mm (4 inch) lower than the drainage port of each unit. In this case, thicker pipes should be applied.

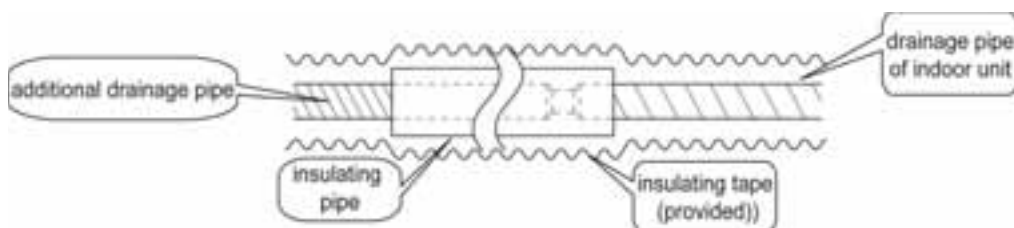

Fig 4.3.1

4.3.2 Drainage pipe installation

- (1) Insert the drain hose into the drain hole and tighten it with tapes, as shown in Fig 4.3.2.

- (2) Tighten the pipe clamp, with the distance between screw nut and hose smaller than 4mm (1/8inch).

- ① metal clamp(accessory)
- ② drain hose(accessory)

- (3) Use sealing plate to insulate the pipe clamp and hose, as shown in Fig. 4.3.3.

- ① metal clamp(accessory)
- ② thermal sponge(accessory)

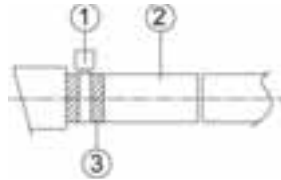

Fig 4.3.2

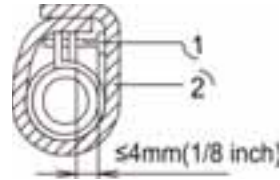

Fig 4.3.3

- (4) When connecting several drain pipes, follow the instruction as shown in Fig. 4.3.4. Choose the drain collecting pipe that matches unit capacity.

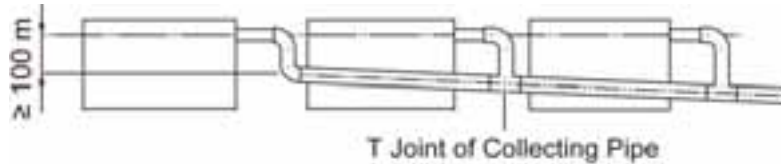

Fig 4.3.4

- (5) Install the trap as shown in Fig. 4.3.5.
- (6) Install one trap for each unit.
- (7) Sufficient clearance should be maintained for access to trap for service and cleaning..



Fig 4.3.5

- (8) The horizontal pipe can be connected to vertical pipe in the same level; please select the connection way as shown in the following.

Fig. 4.3.6: Connection of drainage pipe joints

Fig. 4.3.7: Connection of downspout elbow

Fig. 4.3.8: Inserting pipe connection

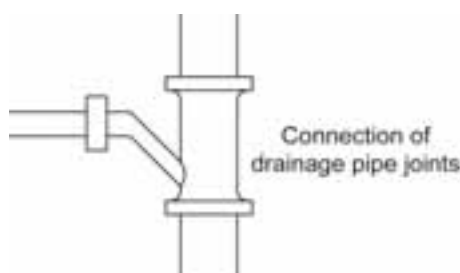

Fig 4.3.6

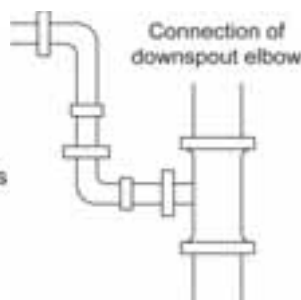

Fig 4.3.7

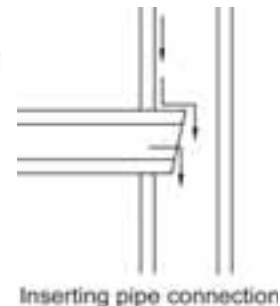

Fig 4.3.8

- (9) The installation height of raising pipe for drainage should be lower than 850 mm (34 inch). The downward slope of raising pipe should be at least 1%~2%. If the raising pipe is vertical, the raising height should be less than 800 mm (32 inch).

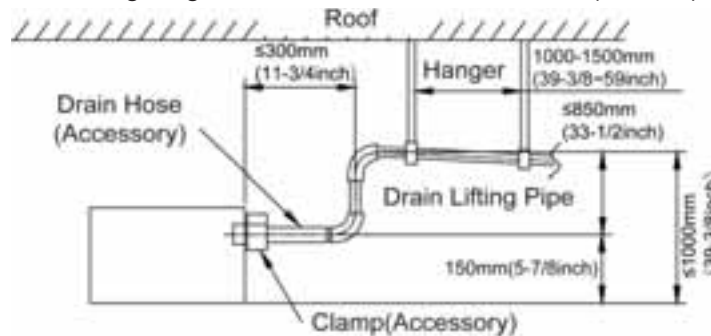

Fig 4.3.9

- (10) Drain pipes should have a downward slope of at least 1%~2%. To prevent pipes from sagging, install hanger bracket at intervals of 1000~1500 mm (39~59 inch).

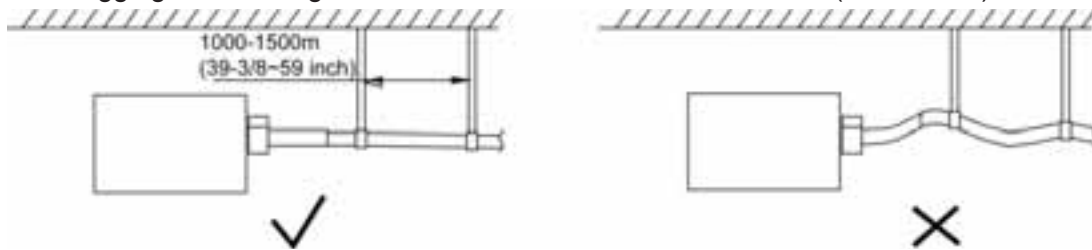

Fig 4.3.10

4.3.3 Test of Drainage System

- (1) Please test drainage system after electric work is finished.
 - 1) Add approximately 1L (1 qt) purified water to drain pan from air vent. Be careful not to splash the water over the electrical components (e.g. water pump, etc).
 - 2) Turn on power to the IDUs and switch to cooling or dry mode. The water pump should operate. Check the draining through the drain socket.
 - 3) If communication wire is not connected, communication malfunction "C0" will occur 60s after startup. In this case, the water pump should operate automatically. Check if the water pump drains normally through drainage port. The water pump will stop automatically after running for 10mins.
- (2) During the test, check the drainage joint for leakage.
- (3) It's strongly recommend to do the drain test before ceiling decoration.

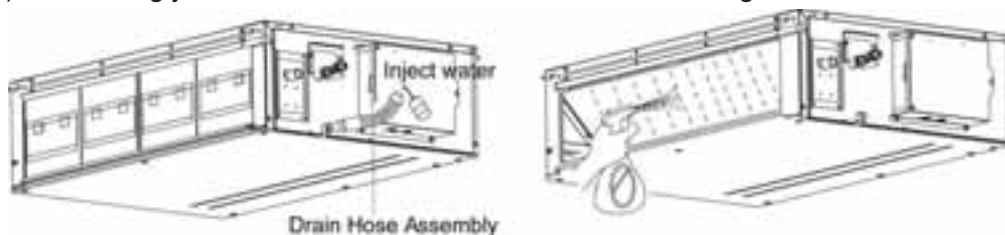

Fig 4.3.11

4.4 Installation of Air Duct

Note:

- ① There should be insulating layer on air-out duct, air-return duct and fresh air duct to avoid heat loss and moisture. Attach a nail on the air duct and then add thermal sponge with a layer of tin. Fasten it with a nail cover and then seal the junction with tin tape. You can use other materials that have good insulation value.
- ② Each air-out duct and air-return duct should be secured on a pre-made board with iron frame. The junction of air duct should be sealed well in order to prevent air leakage.
- ③ The design and construction of air duct should comply with national requirements.
- ④ Manufacturer suggests the air-return duct to be more than 150mm(6 inch) away from the wall. Add a filter to the air-return opening.
- ⑤ Please consider noise and vibration dampening for the design and construction of air duct. For quieter conditions air duct openings should be installed in areas away from living or working spaces. For example, do not install an air return directly above a desk or sitting area.

4.4.1 Installation of Air-out Duct

(1) Installation of the Rectangular Duct

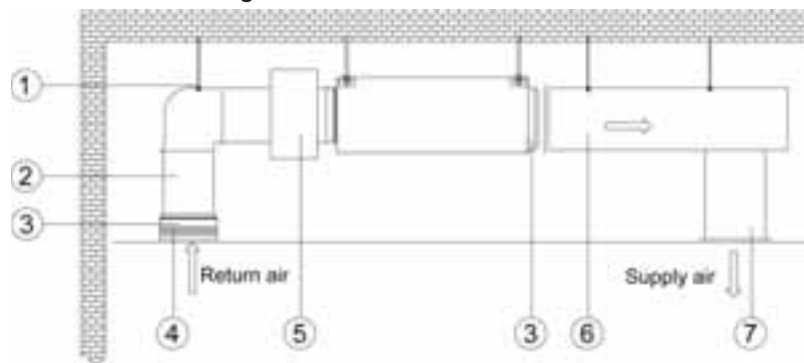

Fig 4.4.1

No.	Name	No.	Name
1	Hanger Rod	5	Static Pressure Box
2	Return Air Duct	6	Main Supply Air Duct
3	Canvas Duct	7	Supply Air Outlet
4	Return Air Inlet		

4.4.2 Shape and Size of Air Outlet and Air-return Opening

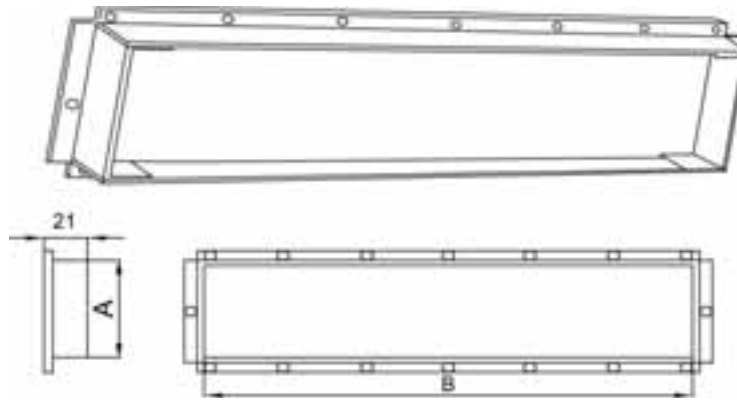

Fig 4.4.2 Air Outlet

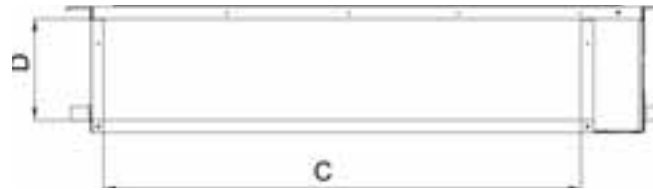

Fig 4.4.3 Air-return Opening

Model	Size of Air Outlet		Size of Air -return Opening	
	A	B	C	D
BDDH-5.6(18)SAK BDDH-7.1(24)SAK	158 (6-1/4)	818 (32-1/4)	994 (39-1/8)	195 (7-5/8)
BDDH-9.0(30)SAK BDDH-11.2(36)SAK BDDH-12.5(42)SAK BDDH-14.0(48)SAK	158 (6-1/4)	818 (32-1/4)	100 (3-7/8)	206 (8-1/8)

4.4.3 Installation of the Return Air Duct

- (1) The default installation location of the rectangular flange is at the back and the return air cover plate is at the bottom, as shown in Fig 4.4.4.

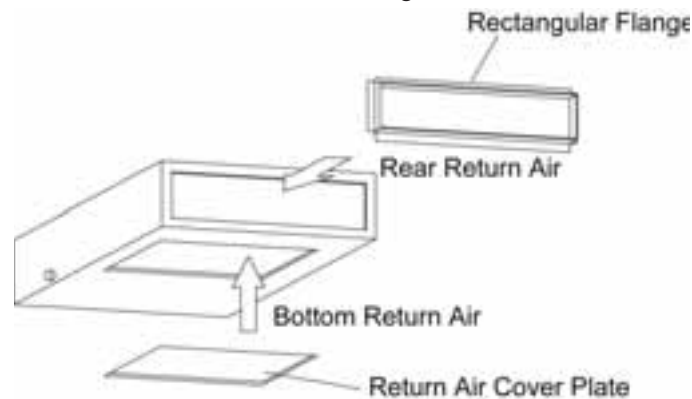

Fig 4.4.4

- (2) The installation method can be configured to match the requirements of the building and maintenance etc., as shown in Fig. 4.4.5.

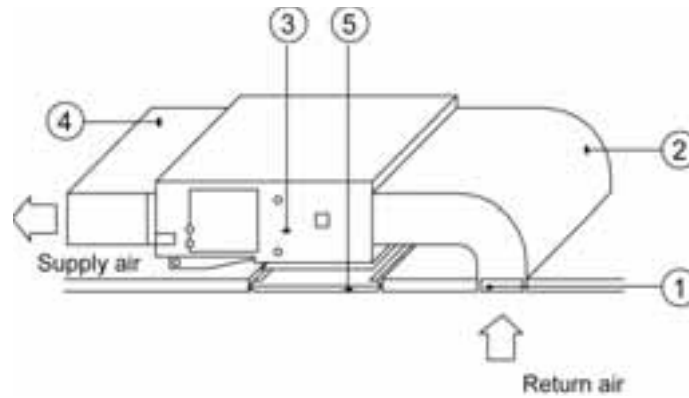

Fig 4.4.5

Table 5 Installation of the return air duct

No.	Name	No.	Name
1	Return Air Inlet (with filter)	4	Supply Air Duct
2	Return Air Duct	5	Grille
3	Indoor unit		

4.5 Installation of Wired Controller

Please refer to User Manual of Wired Controller for the installation details.

NOTICE! When installation is finished, the unit must be tested and debugged before operation. Please refer to Instruction Manual of ODU for auto addressing and debugging details.

5 Wiring Work

WARNING

Before accessing terminals, all supply circuits must be disconnected.

NOTICE

- | |
|---|
| (1) Units must be grounded securely, or it may cause electric shock. |
| (2) Please carefully read the wiring diagram. Faulty wiring could cause malfunction or damage the unit. |
| (3) The unit should have dedicated power supply. |
| (4) The wiring should be in accordance with related regulations. |
| (5) Install circuit breaker for branch circuit according to related regulations and electrical standards. |
| (6) Keep cable away from refrigerant piping, compressor and fan motor. |
| (7) The communication wires should be separated from power cord and connection wire between indoor unit |
| (8) Adjust the static pressure with wired controller according to site conditions. |

5.1 Connection of Wire and Patch Board Terminal

- (1) Single wire connection (as shown in Fig. 5.1.1)
 - 1) Strip about 25mm (1 inch) insulation of the wire end with wire stripper.
 - 2) Remove the wiring screws on the terminal board.
 - 3) Shape the tail of wire into ring with needle nose pliers. Ring should match the size of the terminal screw.
 - 4) Use the screwdriver to tighten the terminal.
- (2) Stranded wire connection (as shown in Fig. 5.1.2)
 - 1) Strip about 10mm (3/8 inch) insulation of the end of the wire with wire stripper.
 - 2) Remove the wiring screws on terminal board.
 - 3) Insert the wire into the ring tongue terminal and tighten with crimping tool.
 - 4) Use the screwdriver to tighten the terminal.

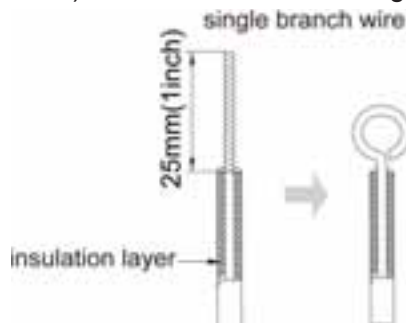

Fig 5.1.1

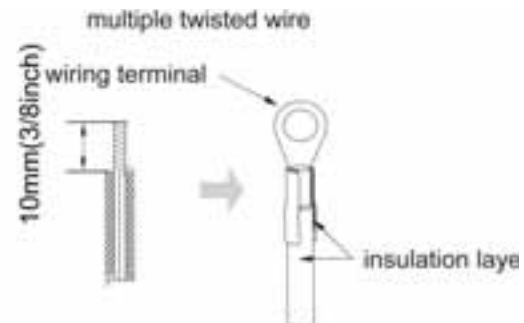

Fig 5.1.2

5.2 Power Cord Connection

NOTICE! All indoor units must have dedicated power supply so that they can be powered ON/OFF at the same time.

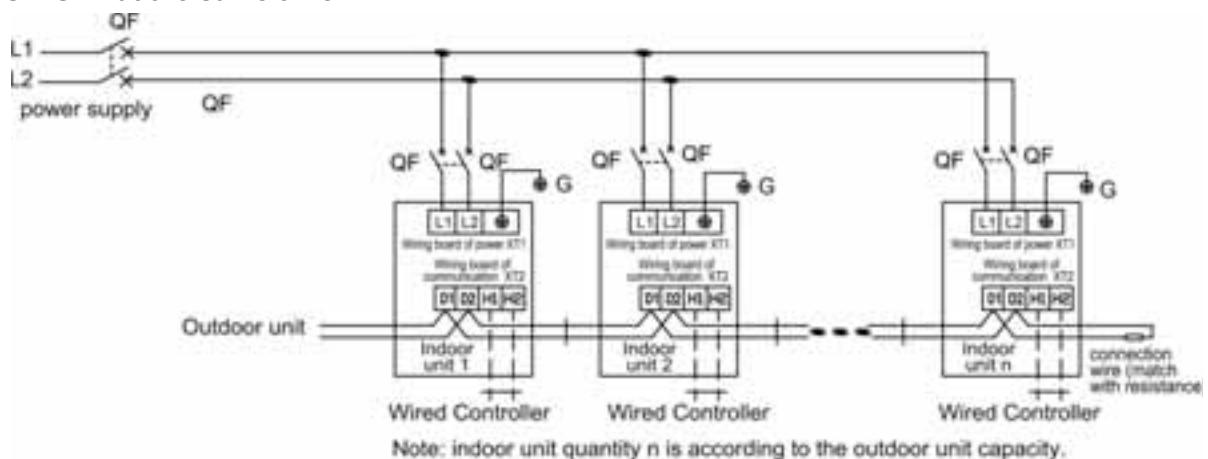

Fig 5.2

- For units with single-phase power supply.
 - (1) Detach the electric box lid.
 - (2) Lead the power cord through the wiring holes.
 - (3) Connect the power cord to terminal "L1, L2, ".
 - (4) Secure the power card with wiring clamp.
 - (5) The wire diameter of power cord can't be less than 18AWG.

5.3 Connection of Communication Wire between Indoor Unit and Outdoor Unit (or indoor unit)

- (1) Detach the electric box lid.
- (2) Lead the Communication cable through the wiring holes.
- (3) Connect the communication wire to terminal D1 and D2 of indoor 4-bit wiring board, as shown in Fig. 5.3.1.



Fig 5.3.1

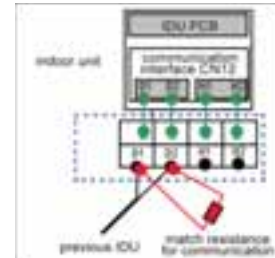

Fig 5.3.2

- (4) Secure the communication cable with clamp of electric box.
- (5) For more reliable communication, connect the terminal resistor to the most downstream IDU of the communication bus (terminal D1 and D2), as shown in Fig. 5.3.2, a terminal resistor is provided with each ODU.

5.4 Connect Communication Wire of Wired Controller

- (1) Open electric box cover of indoor unit.
- (2) Lead the communication wire through the rubber ring.
- (3) Connect the communication wire to terminal H1 and H2 of indoor 4-bit wiring board.
- (4) Secure the communication wire with wire clip on the electric box.
- (5) Wiring instructions of remote receiving light board and wired controller:
 - 1) Fig 5.4.1 shows the installation of wired controller.

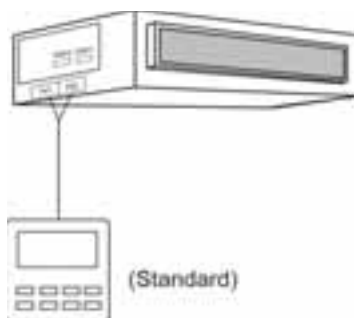

Fig 5.4.1

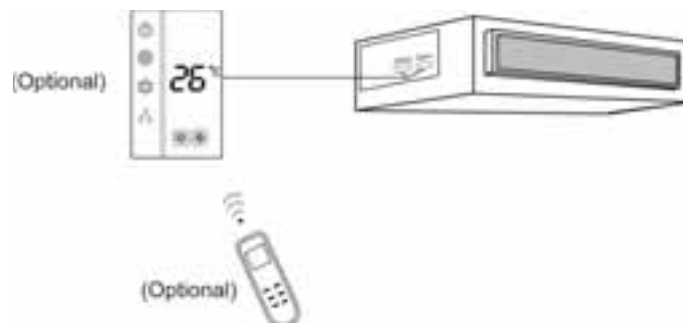

Fig 5.4.2

- 2) Fig 5.4.2 shows the installation of remote controller.
- 3) Wired controller and receiving light board can be used on the same unit. When operating through a remote controller, both wired controller and the receiving light board can receive the signals, as shown in Fig. 5.4.3.

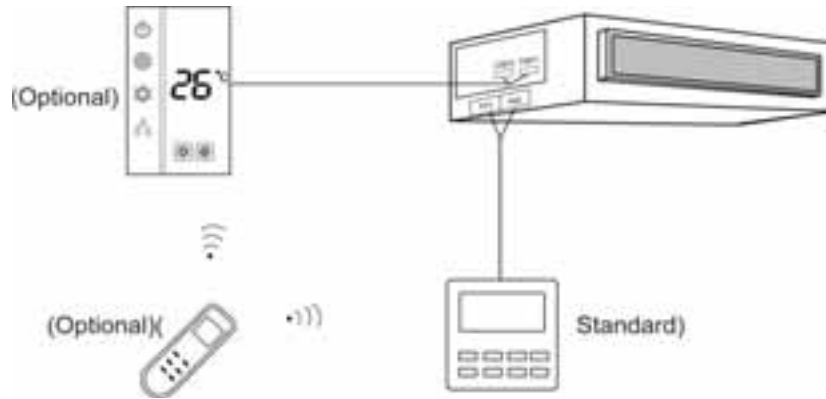

Fig 5.4.3

5.5 Connection of Wired Controller and Indoor Units Network

- (1) Communication wire of indoor unit to outdoor unit (or indoor unit) is connected to D1, D2.
- (2) Wired controller is connected to H1, H2.
- (3) One indoor unit can connect two wired controllers. One must be set as master and one as slave.
- (4) One wired controller can control 16 indoor units maximum at the same time (as shown in Fig. 5.5)

NOTICE

- (1) The indoor units must be the same type if they are controlled by a single wired controller.
- (2) When the indoor unit is controlled by two wired controllers, the addresses of the two wired controllers should have different address settings. Address 1 is for main controller. Address 2 is for slave controller. Detailed setting please refers to the instruction manual of wired controller.

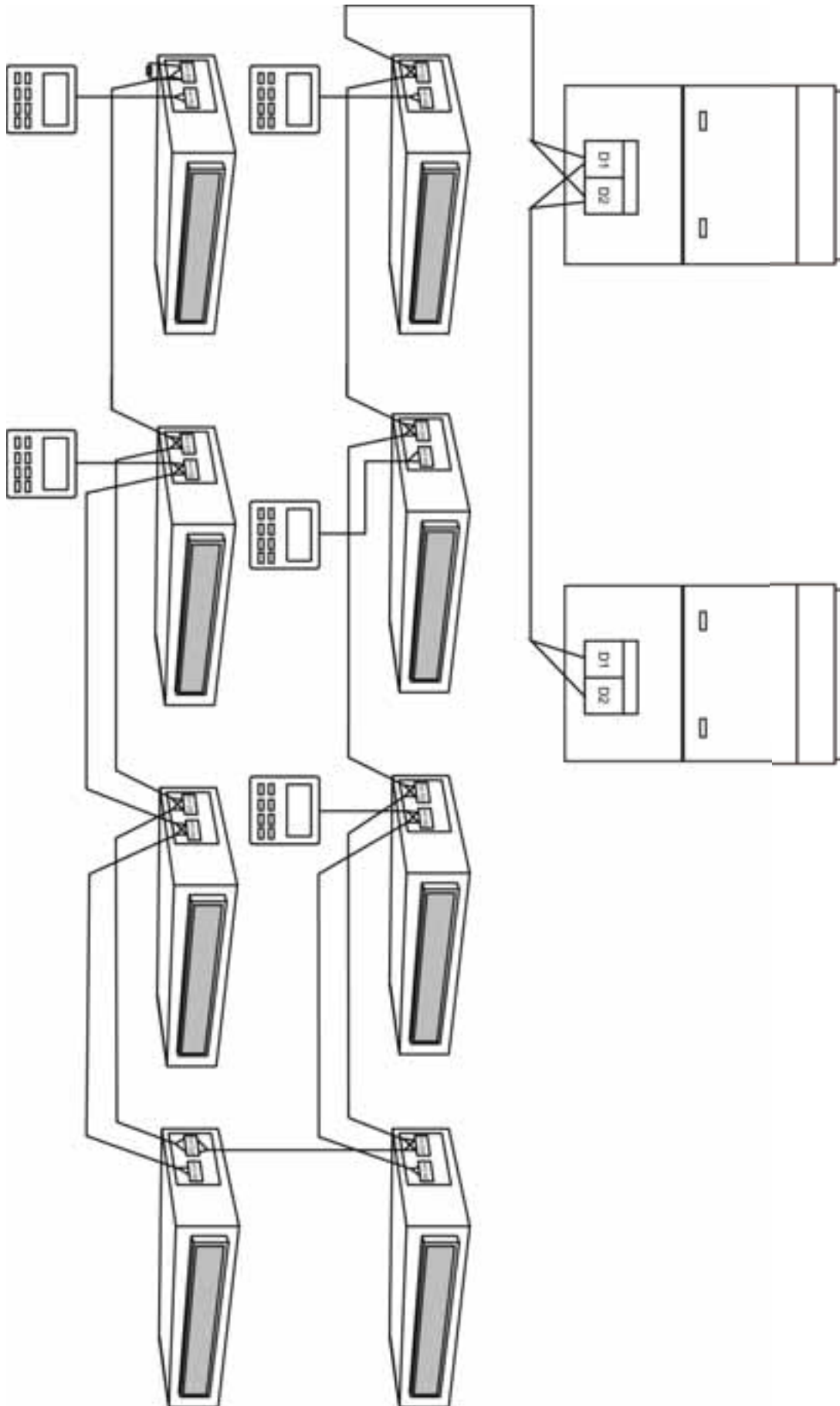

Fig 5.5

6 Routine Maintenance

NOTICE

(1) Turn off the unit and cut off the main power supply when cleaning the air conditioner to avoid electric shock or injury.
--

(2) Use a ladder or other stable platform when cleaning the unit.

(3) Do not clean the unit with hot water whose temperature is higher than 45°C (113°F) to prevent fading or warping.
--

(4) Do not dry the filters over open flame to avoid warping.
--

(5) Clean the filter with a damp cloth dipped in mild detergent.
--

(6) Please contact a qualified service technician if there is a malfunction.
--

6.1 Cleaning of Filter

- (1) Remove the filters from inlet of IDU. Use a vacuum cleaner to remove dust. If the filters are dirty, wash them with warm water and mild detergent. Dry the filters in the shade.
- (2) If the unit is used in a very dusty environment, please clean it more frequently (about every two weeks).

6.2 Preseason Maintenance

- (1) Check if the air inlet and air outlet of indoor and outdoor unit are blocked.
- (2) Check if securely grounded.
- (3) Check if all the power cords and communication cables are securely connected.
- (4) Check if any error code displayed after turning on power.

6.3 Post-Seasonal Maintenance

- (1) Set the unit in fan mode for half a day on a sunny day to dry the inner parts of unit;
- (2) When the unit won't be used for a long period of time, please turn off power supply to save energy. The characters on the wired controller screen will disappear after turning off the power supply.

7 Table of Error Codes for Indoor Unit

Error Code	Content	Error Code	Content	Error Code	Content
L0	Indoor Unit Error	L9	Quantity Of Group Control Indoor Units Setting Error	d8	Water Temperature Sensor Error
L1	Indoor Fan Protection	LA	Indoor Units Incompatibility Error	d9	Jumper Cap Error
L2	E-heater Protection	LH	Low Air Quantity Warning	dA	Indoor Unit Hardware Address Error
L3	Water Full Protection	LC	Outdoor-Indoor Incompatibility Error	dH	Wired Controller PC-Board Error
L4	Wired Controller Power Supply Error	d1	Indoor Unit PC-Board Error	dC	Capacity DIP Switch Setting Error.
L5	Anti-Frosting Protection	d3	Ambient Temperature Sensor Error	dL	Outlet Air Temperature Sensor Error
L7	No Master Indoor Unit Error	d4	Inlet Pipe Temperature Sensor Error	dE	Indoor Unit CO ₂ Sensor Error
L8	Power Insufficiency Protection	d6	Outlet Pipe Temperature Sensor Error	db	Special Code: Field Debugging Code

8 Troubleshooting

The air conditioner should not be serviced by users. Faulty repair may cause electric shock or fire, so please contact an authorized service center for professional service. Check the following before calling for service help.

Malfunction	Troubleshooting
The unit won't start	<ul style="list-style-type: none"> ① Power supply is not connected. ② Circuit breaker tripping caused by electrical short. ③ Input voltage is too low. ④ Defect of main PC-board.
The unit runs for a short while, then stops.	<ul style="list-style-type: none"> ① The inlet or outlet of ODU or IDU are blocked.
Poor cooling effect	<ul style="list-style-type: none"> ① The filter is dirty. ② Too heavy heat load of room (e.g. too many people) ③ Doors or windows are open. ④ Inlet or outlet of IDU are blocked. ⑤ Thermostat setting temperature is too high. ⑥ Refrigerant charge is low (e.g. refrigerant leakage)
Poor heating effect	<ul style="list-style-type: none"> ① The filter is dirty. ② Doors or windows are open. ③ Thermostat setting temperature is too low. ④ Refrigerant charge is low (e.g. refrigerant leakage)
Indoor fan doesn't start up during heating	<ul style="list-style-type: none"> ① At starting, the IDU fan could not operate till the heat exchanger warms up oprevent delivery of cool air. ② Unit is defrosting. The IDU fan stopped due to system switch to cooling mode to prevent delivery of cool air. It will resume operating after defrosting.

Note:

If air conditioner still fails to work normally after checking and handling as described above, please stop using it immediately and contact local service center for assistance.

**Specifications & illustrations subject to change without
notice or incurring obligations.
O'Fallon, MO (12/15) © Nortek Global HVAC, LLC 2015.
All Rights Reserved. 552E-1215**



66170050004