

# INSTALLATION INSTRUCTION

## INSTALLATION INSTRUCTIONS FOR 560199 ECONOMIZER USED WITH (B4,B5)SM 090/120 SERIES AIR HANDLER

FORM # 572D-1210

### I - Shipping and Packing List

Package 1 of 1 contains:

- 1 - Economizer Assembly
- 1 - Controls and Wiring Harness Assembly
- 3 - Wire Nuts
- 14 - #10 x 1/2

Check contents for shipping damage. Contact the last carrier immediately if any shipping damage is found.

### II - Application

Economizers are used with Nordyne (B4,B5)SM Series Air Handlers for automatic sensor-controlled introduction of outdoor air into the system through an electro-mechanically controlled damper. Outdoor air is mixed with the buildings return air to economically improve indoor air quality and aide in reducing energy costs.

Economizers can be utilized in either Horizontal or Vertical air handler applications and are easily mounted over the air handler return air and filter frame assembly, The C-7150 Mixed Air Sensor is shipped inside the economizer and must be relocated downstream of the air handler refrigerant coil in accordance with these instructions.

#### Economizer Supply / Return Duct Connections:

39.75" Wide x 15.63" High (Outside Flange Dimensions)

### Warning:

This kit is to be installed by a qualified service technician in accordance with these instructions and all codes having jurisdiction. Failure to follow these instructions could result in serious injury, property damage, or death. These instructions are primarily intended to assist qualified individuals experienced in the proper installation of this appliance. Some local codes require licensed installation/service personnel for this type of equipment.

### III - Installation

1. DISCONNECT ALL POWER TO THE UNIT.
2. Install and secure the economizer as shown with the air handler in the Horizontal position (**Figure 1**) or in the Vertical position (**Figure 2**) using screws (12) provided in the kit.

**NOTE:** Economizers must be properly supported when installed with this air handler. Support for the economizer is field supplied and the responsibility of the installer to use methods approved by State or Local mechanical building codes having jurisdiction. For Vertical installations, Nordyne Adjustable Support Leg Kit , SKU # 560258 may be used.

3. Connect ductwork to the economizer using flanges provided.

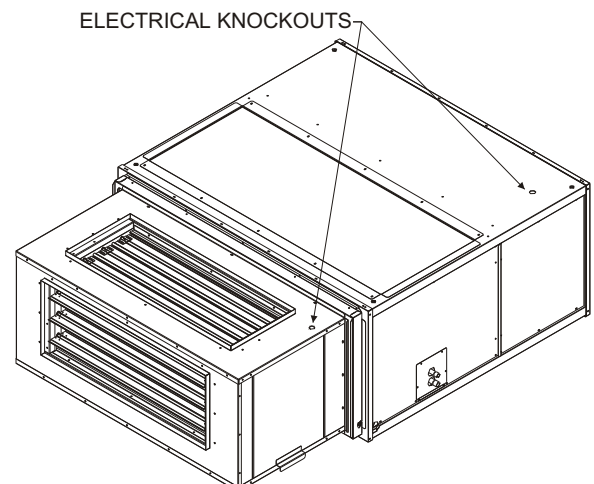
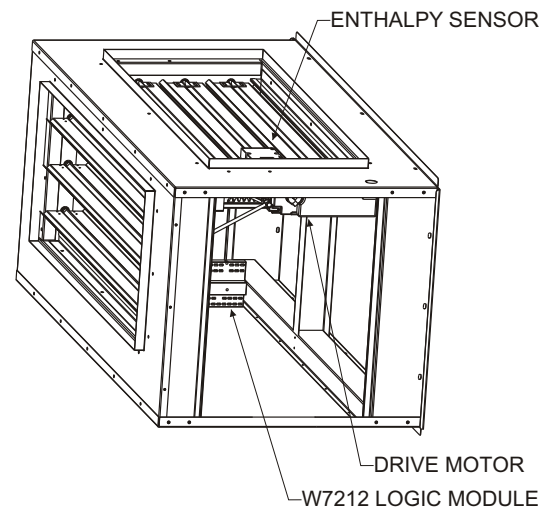
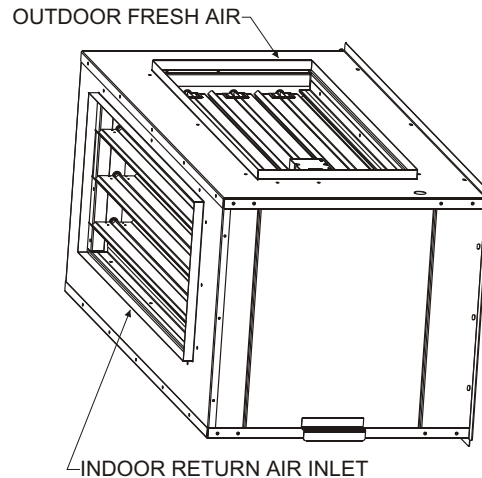

Figure 1 - (B4,B5)SM Horizontal Application

# INSTALLATION INSTRUCTION

## INSTALLATION INSTRUCTIONS FOR 560199 ECONOMIZER USED WITH (B4,B5)SM 090/120 SERIES AIR HANDLER

- 4 Remove the economizer control access panel, the air handler motor access panel, and the air handler control panel cover.
- 5 Remove the electrical knockout on the economizer next to the damper motor and the plastic plug on the air handler panel above the control panel. This will allow routing of the economizer control wiring through a length of 1" conduit, or other equivalent means of wire protection based on State or Local codes which covers 24V Class 2 wiring.
- 6 Cut and discard wire tie securing control wiring bundle inside the economizer. Remove the two red wires from the C-7150 Mixed Air Sensor and mount the sensor to the divider plate located left of the blower motor assembly as shown in **Figure 3** using two screws provided.

**Important - DO NOT cut other wires. Inspect bundle for damaged connections or loose wires.**

7. Route the nine economizer control wires from the economizer quick connect plug through the conduit and into the air handler compartment. Route all wires except for the two red Mixed Air Sensor wires into the control panel through the Low Voltage bushing.
8. Connect the two red wires to the Mixed Air Sensor and secure wires away from the blower and motor components.
9. Nordyne air handlers are designed to work with either A/C or Heat Pump outdoor units. Select the proper wiring diagram for this application on Page 5 and 6 to connect the remaining seven economizer control wires to the air handler.

Replace air handler control panel cover and motor access panel.

### IV - Operation

**Note:** These instructions are written for the economizer to operate with a standard single stage Heat/Cool or Heat Pump thermostat. If 2nd stage mechanical (compressor) cooling is desired a 2 Stage Cool / 1 Stage Heat thermostat is required.

#### A. Cooling Mode, Sequence of Operation (Standard)

1. On a call for cooling, with ambient temperature and humidity above enthalpy control setpoint, the refrigerant system will operate normally, and damper will open to minimum vent position. **See Section VI for proper set up and adjustments.**
2. On a call for cooling, with outdoor ambient temperature and humidity suitable for cooling, enthalpy control will shift stage one cooling control to outside air. The economizer damper will modulate, mixing outside air with return air, to control supply air temperature to approximately 55°F (13°C). If additional cooling is required, the compressor can be energized through second stage of an optional two stage Cooling thermostat. Refer to wiring diagrams for proper connections.

\* **Air handler shipped from factory for horizontal application. See air handler installation instructions for conversion from horizontal to vertical application.**

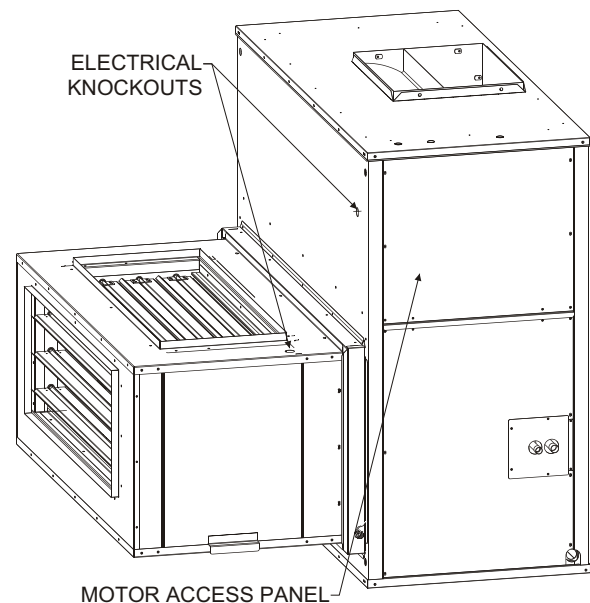

Figure 2 - (B4,B5)SM Vertical Application\*

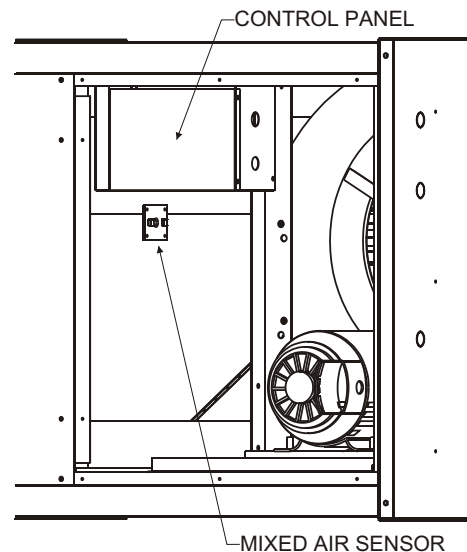

Figure 3 - Mixed Air Sensor Location

# INSTALLATION INSTRUCTION

## INSTALLATION INSTRUCTIONS FOR 560199 ECONOMIZER USED WITH (B4,B5)SM 090/120 SERIES AIR HANDLER

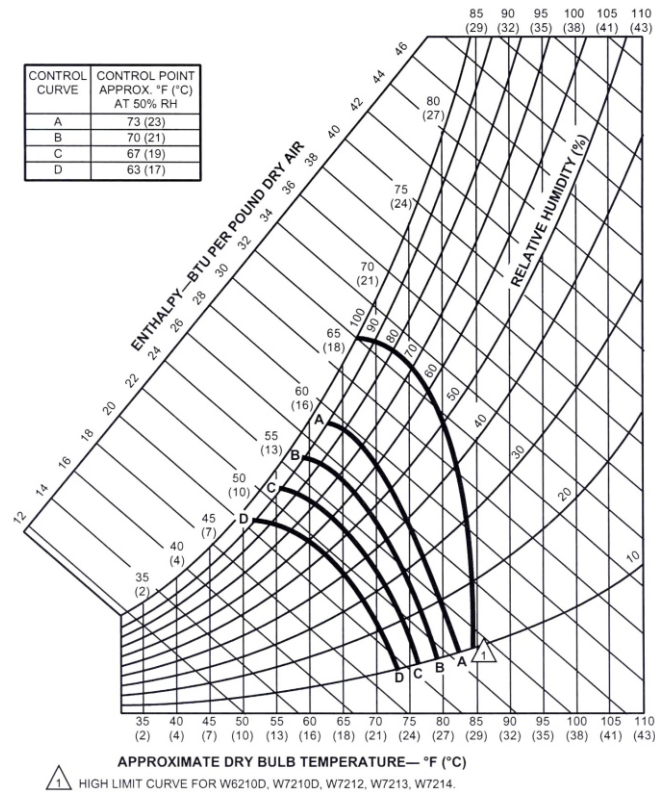

Figure 4

### B. Cooling Mode, Single Enthalpy Control (Factory Standard)

The C7400A enthalpy control senses both temperature and humidity or the heat content of the outside air. It controls the amount of outdoor air brought into the system. When the heat content of the outside air is below control setpoint, the control modulates outdoor dampers to meet cooling needs of the building. When the heat content rises above control setpoint, the control closes outdoor dampers to minimum position. The recommended setpoint is "A". If Economizer is allowing air which is too warm or too humid to enter the system, control may be changed to a lower setpoint (B, C, or D). Refer to Figure 4 and Figure 5.

### C. Heating Mode (Heat Pump Application ONLY)

- On a call for heat the fresh air damper will open to the minimum vent position.

### V - Economizer Set Up Procedures

**Notice to Installer:** Proper operation of this economizer when used with an outdoor **HEAT PUMP** system is dependent on the type thermostat installed with the unit. Identify which type thermostat is connected to unit before making any wiring changes if needed.

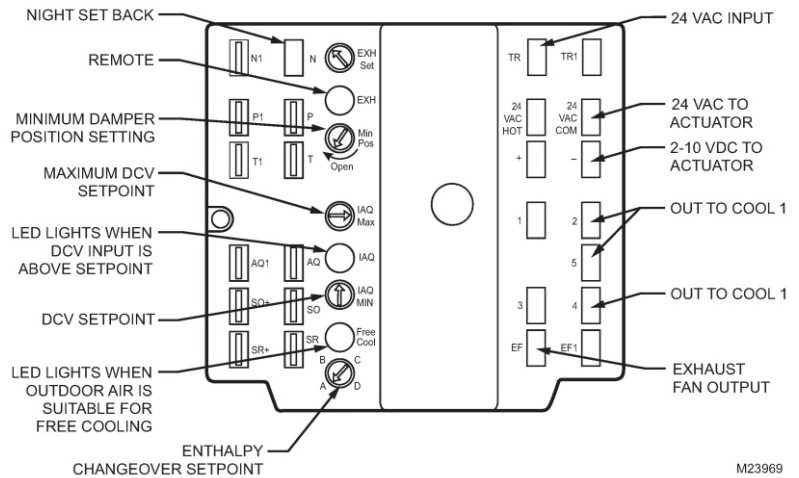

Figure 5

(B4,B5)SM air handler economizers come equipped with Honeywell W7212 logic modules which offer additional connections for Demand Control Ventilation (DCV) and Power Exhaust. Contact your local Honeywell or Tradeline representative for additional information on these controls and their specific applications

# INSTALLATION INSTRUCTION

## INSTALLATION INSTRUCTIONS FOR 560199 ECONOMIZER USED WITH (B4,B5)SM 090/120 SERIES AIR HANDLER

### Heat Pump Thermostat – Single "O/B" terminal for selection of Reversing Valve Control.

(B4,B5)SM Series economizers are pre-wired to work in conjunction with single stage Heat Pump thermostats that utilize the "O" terminal to energize the reversing valve when the thermostat "System Switch" is set in the "Cool" mode. Refer to these installation instructions and wiring diagrams for proper connection and operation of the economizer. When the system switch is in the OFF, HEAT, or EMERGENCY HEAT mode setting the economizer is automatically locked out during heating operation. It holds the outdoor fresh air damper at the minimum position setting only when the air handler is operating. **Refer to Section VI – Minimum Damper Position for proper set up and operation.**

### VI - SYSTEM CHECK AND START UP PROCEDURES

#### Minimum Damper Position Adjustment.

Damper minimum position keeps the outdoor air damper from closing completely during system operation for ventilation of building contaminants and people occupancy. Consult your State or local codes as required.

1. **Disconnect main power to outdoor unit and air handler.**
2. Set thermostat "SYSTEM" switch to "OFF" position and "FAN" switch to "AUTO".
3. Install jumper wire across air handler low voltage terminal board "R" and "G" terminal.
4. Disconnect mixed air sensor from the W7212 terminals T and T1 and short terminals T and T1. See Figure 5.
5. Ensure the factory installed jumper is in place across terminals P and P1.
6. Calculate the appropriate mixed air temperature per the following equation:

\*  $(\text{Return Air Temp.} \times \% \text{ of Return Air}) + (\text{Outside Air Temp.} \times \% \text{ of Outside Air}) = \text{Mixed Air Temperature}$

#### Example:

Assume local code requires 10% outdoor air during occupied conditions, (200 CFM of total unit CFM = 2,000) outdoor air is 60°F, and return air is 75°F. Under these conditions, what is the mixed air temperature?

$$(0.1 \times 60^\circ\text{F}) + (0.9 \times 75^\circ\text{F}) = 6.0^\circ\text{F} + 67.5^\circ\text{F} = 73.5^\circ\text{F}$$

7. Restore power to the outdoor section and air handler.
8. Carefully adjust the MIN POS potentiometer on the W7212 control module with a small screwdriver until the mixed air temperature reaches the calculated value.
9. Once minimum position adjustments are completed, turn off power to the outdoor unit and air handler. Damper will move to fully close.

10. Remove jumper wire across "R" and "G" on the low voltage terminal board and T and T1 on the W7212 control module.

#### 11. Reconnect the mixed air sensor.

#### 12. Restore power to outdoor unit and air handler.

### VII - MAINTENANCE

1. Damper motor is prelubricated and does not require further lubrication.
2. Make visual inspection of dampers and linkage assemblies during routine maintenance.
3. Filters should be checked periodically and cleaned when necessary.
4. The washable filters supplied with the economizer can be cleaned with water and a mild detergent.
5. Take note of "Air Flow Direction" marking on filter frame when reinstalling.
6. If filter must be replaced, filter of like kind and size must be used. **DO NOT** replace permanent filters with throwaway type filters.

HARNES DETAIL		COMPONENT CODE		WIRE COLOR CODE		Revision		Change		Date	
<b>E# = WIRE END DESIGNATION</b>			<b>Economizer</b>			BLK Black					
E2	STUD #6 18 Ga. Wire	C7400A	Fresh Air Enthalpy Sensor	BLU	Blue						
E3	Female ¼ Quick Disc.	C7150	Mixed Air Sensor	BRN	Brown						
E4	Male ¼ Quick Disc. Insul	MS7510A	Damper Actuator 24v	GRY	Gray						
E6	Wire Nut Size 73B	W7212A	Logic Module	RED	Red						
		TB-11	Terminal Block	YEL	Yellow						
				WHT	White						

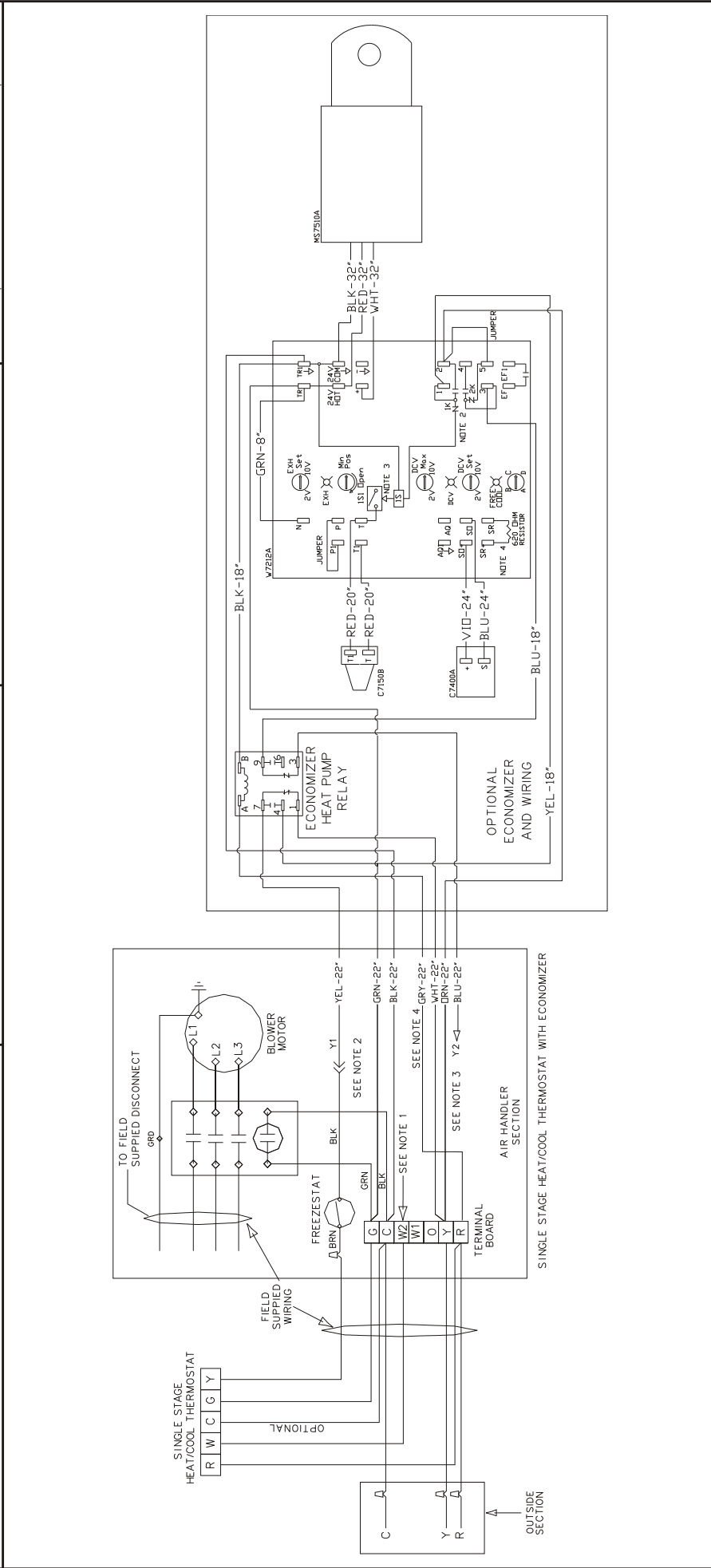

**Modulating Economizer 560199 (B4,B5)SM 090/120 Series Air Handler**

**RUSKIN®**  
**ROOFTOP SYSTEMS**  
 1625 Diplomat Drive  
 Carrollton, Texas 75006  
 Phone: (972) 247-7447  
 Fax: (972) 243-0940

Date: February 4, 2011  
 Supersedes:  
 Drawn by:  
 Unit #: 47-374-01  
 Diagram#: 4737401w  
 Approved by:

- C & W2 to be connected to optional electric heat.
- Remove BLACK wire from air handler low voltage terminal board Y terminal and connect to YELLOW wire from economizer.
- Second Stage refrigerant cooling with optional economizer installed. A 2 stage thermostat is required for simultaneous operation of the economizer and refrigerant system. Connect Y2 from 2 stage thermostat to BLUE wire from economizer.
- Heat Pump Economizer Relay. For heat pump applications only. Required for proper operation of an economizer (optional) in the heat pump Heating mode. **CONNECT TO "R" FOR AC ONLY APPLICATIONS.**

HARNES DETAIL		COMPONENT CODE		WIRE COLOR CODE		Revision		Change		Date	
<b>E# = WIRE END DESIGNATION</b>	<b>Economizer</b>	Fresh Air Enthalpy Sensor	BLK	Black	BLU	Blue					
E2 STUD #6 18 Ga. Wire	C7400A	Mixed Air Sensor	BRN	Brown	GRN	Green					
E3 Female ¼ Quick Disc.	C7150	Damper Actuator 24v	ORN	Orange	RED	Red					
E4 Male ¼ Quick Disc. Insul	MS7510A	Logic Module	VIO	Violet	YEL	Yellow					
E6 Wire Nut Size 73B	W7212A	Terminal Block	WHT	White							
	TB-11										

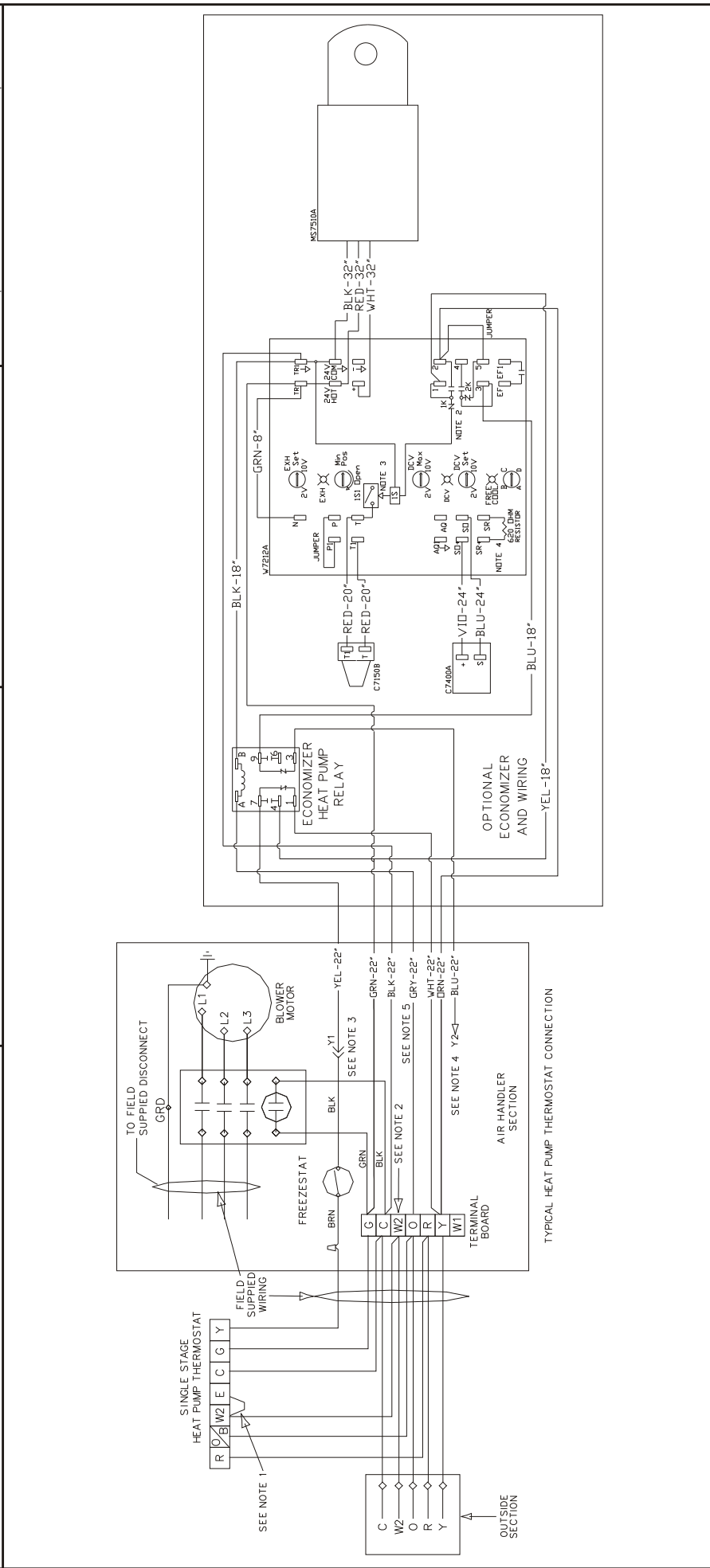

- Jumper between W2 and E is required.
- C & W2 to be connected to electric heat.
- Remove BLACK wire from air handler low voltage terminal board Y terminal and connect to YELLOW wire from economizer.
- Second Stage refrigerant cooling with optional economizer installed. A 2 stage thermostat is required for simultaneous operation of the economizer and refrigerant system. Connect Y2 from 2 stage thermostat to BLUE wire from economizer.
- Heat Pump Economizer Relay. Required for proper operation of an economizer (optional) in the heat pump Heating mode. **Refer to economizer installation instruction for proper connection to thermostat.**

**Modulating Economizer**  
560199  
(B4,B5)SM 090/120 Series Air Handler

**RUSKIN**  
**ROOFTOP SYSTEMS**

1625 Diplomat Drive  
Carrollton, Texas 75006  
Phone: (972) 247-7447  
Fax: (972) 243-0940

Date: February 4, 2011  
Supersedes:  
Drawn by:  
Unit #: 47-374-01  
Diagram#: 4737402W  
Approved by:



