

LP & HIGH ALTITUDE LP GAS CONVERSION KIT FOR INSTALLATIONS IN THE UNITED STATES (0 -7,000 FT)

INSTALLATION INSTRUCTIONS

FOR (*)R4(M,N) & R6GN (150/180 MODELS) LIGHT COMMERCIAL PACKAGE GAS/ELECTRIC UNITS

INSTALLERS: Please read all instructions before converting the furnace. Pay attention to all safety warnings and any other special notes highlighted in the manual. Safety markings are used frequently throughout this manual to designate a degree or level of seriousness and should not be ignored. **WARNING** indicates a potentially hazardous situation that if not avoided, could result in personal injury or death. **CAUTION** indicates a potentially hazardous situation that if not avoided, may result in minor or moderate injury or property damage

This conversion kit is only to be used to convert a natural gas unit to LP/Propane gas or to an LP high altitude application in the United States. This kit may only be used in units installed in altitudes between zero and 7,000 feet above sea level. For installations in Canada, the Canadian conversion instructions must be used.

IMPORTANT NOTE: DO NOT REMOVE OR DEFACE THE ORIGINAL RATING PLATE.

This conversion kit is backwards compatible with (*)R4(M,N) & R6GN (150-180 Model) units. Contact NORDYNE Technical Services for more information on these appliances.

Table 1 is a detailed listing of components required for converting light commercial units to LP Gas for altitudes between 0 & 7,000 feet. Please check the contents of the conversion kit with that of the parts listing, and familiarize yourself with each component.

DESCRIPTION	QTY
Gas Valve (Nordyne P/N 624695) (White Rodgers P/N 36H64-463B1)	1
Main LP Burners	7
White Rodgers Conversion Kit #F0092-1008 Converts Nordyne Valve - P/N 624695 (36H64-463B1)	1
#49 Drill Size Burner Orifice Kit (Contains 7)	1
#50 Drill Size Burner Orifice Kit (Contains 7)	1
#51 Drill Size Burner Orifice Kit (Contains 7)	1
Conversion Warning Label - P/N 703935	1
Conversion Information Label - P/N 710005	1
Installation Instructions - P/N 708393	1

Table 1. Conversion Kit Contents

The installer performing this work assumes all responsibility for this conversion. These instructions are primarily intended to assist qualified individuals experienced in the proper installation of these components. Some local codes require licensed installation/service personnel for this type of equipment. Safety should always be the deciding factor when installing this product and using common sense plays an important role as well. Improper installation of the components or failure to follow safety warnings could result in serious injury, death, or property damage. After completing the installation, return these instructions to the Homeowner's Package for owner-user's future reference.

⚠ WARNING:

FIRE OR EXPLOSION HAZARD

- Failure to follow safety warnings exactly could result in serious injury or property damage.
- Installation and service must be performed by a qualified installer, service agency or the gas supplier.
- Do not store or use gasoline or other flammable vapors and liquids in the vicinity of this or any other appliance.

WHAT TO DO IF YOU SMELL GAS

- Do not try to light any appliance.
- Do not touch any electrical switch; do not use any phone in your building.
- Leave the building immediately.
- Immediately call your gas supplier from a neighbor's phone. Follow the gas supplier's instructions.
- If you cannot reach your gas supplier, call the fire department.

DO NOT DESTROY THIS MANUAL. KEEP IN A SAFE PLACE FOR FUTURE REFERENCE.

⚠ AVERTISSEMENT

RISQUE D'INCENDIE OU D'EXPLOSION

- Le non-respect des avertissements de sécurité pourrait entraîner des blessures graves, la mort ou des dommages matériels.
- L'installation et l'entretien doivent être effectués par un installateur qualifié, un organisme de service ou le fournisseur de gazstaller, service agency or the gas supplier.
- Ne pas entreposer ni utiliser de l'essence ni d'autres vapeurs ou liquides inflammables dans le voisinage de cet appareil, ni de tout autre appareil.

QUE FAIRE S'IL Y A UNE ODEUR DE GAZ

- Ne pas tenter d'allumer aucun appareil.
- Ne toucher à aucun interrupteur électrique; n'utiliser aucun téléphone dans le bâtiment.
- Évacuer l'immeuble immédiatement.
- Appeler immédiatement le fournisseur de gaz en employant le téléphone d'un voisin. Respecter à la lettre les instructions du fournisseur de gaz.
- Si personne ne répond, appeler le service des incendies.

⚠ WARNING:

All gas piping must conform with local building codes, or in the absence of local codes, with the most recent edition of CGA B149.1. **DO NOT** attempt to modify, or tap into existing gas lines yourself. Fire or explosion may result causing property damage, personal injury or loss of life. Failure to follow the safety warnings exactly could result in serious injury, death or property damage.

⚠ WARNING:

All electrical wiring must comply with the latest edition of the Canadian Electrical Code (CSA C22.1 and/or local codes). Failure to follow these instructions could result in possible damage to equipment, serious personal injury, or death.

BEFORE YOU CONVERT THE UNIT

⚠ WARNING:

Shut off the gas supply at the manual gas shutoff valve, before disconnecting the electrical power. A fire or explosion may result causing property damage, personal injury or loss of life. Failure to follow the safety warnings exactly could result in serious injury, death or property damage.

⚠ WARNING:

To avoid electric shock, personal injury, or death, turn off the electric power at the disconnect or the main service panel before making any electrical connections.

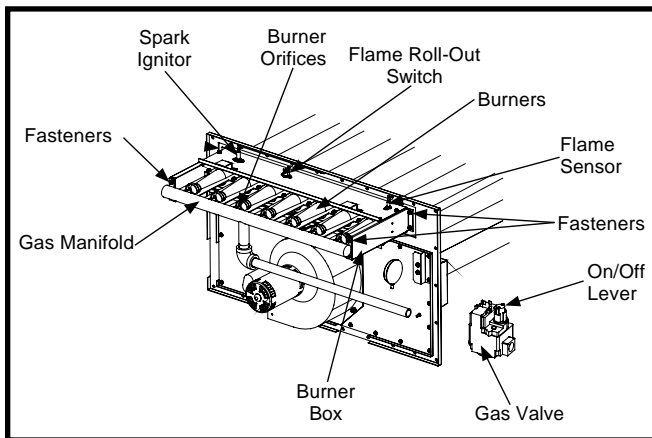

Figure 1. Typical Burner Box
(*R4G(M,N) & R6GN-150 / 180 Series

1. Set the thermostat to the OFF position, or its lowest temperature setting.
2. Shut OFF the gas supply at the manual shutoff valve located outside of the appliance.
3. Turn off all electrical power to the appliance.
4. Remove the louvered burner access panel.
5. Move the gas valve ON/OFF knob to the OFF position. See Figure 2 (page 5)

REMOVING THE BURNER MANIFOLD

1. **STOP!** Read all the steps in the “Before you Convert the Unit” section.
2. Remove the Burner Access Panel louvered door and open the Motor Access panel.
3. Remove Safety Control Access Panel located above burner assembly.
4. Disconnect the Red flame sensor wire, the two Blue flame roll-out switch wires, and the spark ignitor wire at the burner box
5. Remove the White wire from the LOW (M) terminal, the Brown wire from the HI terminal, and the Black wire from the Common (C) terminal of the gas valve.
6. Using two wrenches remove supply gas line, gas valve, and factory gas piping back to the manifold elbow. **DO NOT ALLOW THE BURNER ASSEMBLY TO ROTATE.**
7. Remove the four (4) fasteners that secure the gas manifold to the burner box, as shown in Figure 1. Carefully remove the gas manifold assembly from the burner box. **NOTE:** The gas manifold consists of the gas manifold and the orifices.
8. Carefully remove the burner orifices from the gas manifold, as shown in Figure 1.
9. Remove the four fasteners that secure the burner box to the heat exchanger mounting panel, as shown in Figure 1.
10. Carefully remove the burners from the mounting bracket and set screws aside for later use. Note the alignment of the burners for reassembly purposes.

NOTE: Care should be taken to ensure no damage occurs to the spark ignitor, flame sensor, or roll out limit switch.

**CONVERTING TO LP / PROPANE GAS
(AT ALTITUDES BETWEEN ZERO & 7,000 FT.)**

1. Examine the rating plate of the unit to determine Model number and rated input (Btu/hr).
2. Count the number of burners in the burner box. Verify all information in Table 2 (page 6) to determine the appropriate LP gas orifice size for your application.
3. Install the appropriate LP gas burner orifices into the gas manifold.

NOTE: The size of the new orifices that will be installed into the unit will depend upon the type of conversion (sea level or high altitude). Please refer to the high altitude deration section and Table 2 (page 6) for more details on your particular conversion.

⚠ WARNING:

Do not use Teflon tape or pipe joint compound on the orifice threads. The hole in the orifice may become blocked and cause fire, explosion, property damage, carbon monoxide poisoning, personal injury, or death.

IMPORTANT NOTES:

- Before installing an orifice, check the face or side of the orifice for the drill number to ensure that it is the appropriate size.
- To prevent cross threading, hand tighten the orifices into the gas manifold assembly until snug, then tighten with a wrench 1/2 to 1 turn.
- For units converted for operation above 2,000 ft., follow the High altitude deration instructions.

4. Replace factory burners with the new L.P. burners supplied in this kit. Check burner and carryover alignment (on the burner carryover bar), then fasten securely using all screws removed in Step 9.
5. Reinstall burner box assembly to heat exchanger panel using the four fasteners removed in Step 9.
6. Install manifold pipe with new LP orifices onto the burner box assembly using four fasteners removed in Step 7. Make sure all orifices are aligned into the burners.

NOTE:To complete the conversion from natural gas to LP gas, the main gas valve must be replaced. Main gas valve (#624695), White Rodgers Model # 36H6A must be used.

7. Using two wrenches, carefully reinstall the factory gas piping and new LP Gas Valve to the manifold elbow. **DO NOT ALLOW THE BURNER ASSEMBLY TO ROTATE.** Make sure a leak tight seal using joint compound approved for LP gas or other equivalent approved methods. Secure the gas valve and piping assembly using existing unit clamp.
8. Upon completion of the installation, inspect the alignment of the burners with the heat exchanger tubes. The center of the burners should be aligned with the center of the tubes.
9. Reconnect the main gas piping to the gas valve.
10. Reconnect wiring to the gas valve terminals. White wire to Low (M), Brown wire to HI, and the Black wire to Common (C).
11. Reconnect the spark ignitor wire to the spark ignitor.
12. Reconnect the red flame sensor wire to the flame sensor and two blue wires to the flame roll-out switch.

EXAMPLE 1:

Elevation:3,890 feet
Type of Gas:..... Propane Gas
Unit Model: R6GN-150C180C

At 4,000 feet, the unit needs to be derated by 4% for each 1,000 feet of elevation. This equates to 16% or less than the sea level rating of 153,000 Btu/h.

1. Determine unit input rating:
[153k x (100-16)%] = 129,000 Btu/h. The required heating rate for 3,890 feet is 129,000 Btu/h.
2. Determine orifice size:
From Table 2 (page 6), find the Unit Model Number. Follow across the row and stop at the 2,001 - 4,000 elevation column. For this example, the orifice size displayed is #50. For units equipped with a White-Rodgers gas valve, install one #50 orifice in every burner and check the firing rate. In this example, the firing rate must not exceed 129,000 Btu/h.

HIGH ALTITUDE DERATION

High altitude application with this unit depends on the installation altitude and the heating value of the gas. At high altitudes, the heating value of natural gas is always lower than the heating value at sea level.

All installations of this equipment must be made in accordance with the National Fuel Gas Code or with local jurisdiction codes. For installations at altitudes 2,000 feet or below, the installer does not need to derate the heat exchanger performance.

WARNING:

The reduction of input rating necessary for high altitude installation may only be accomplished with factory supplied orifices. Do not attempt to drill out orifices in the field. Improperly drilled orifices may cause fire, explosion, carbon monoxide poisoning, personal injury or death.

IMPORTANT NOTES:

- For any installation that exceeds 2,000 feet, the input rate must be reduced 4% per 1,000 feet of altitude (Example: 12% at 3,000 feet, 16% at 4,000 feet, etc). Always round up to the next highest value of 1,000. So an installation at 3,120 feet is derated by 16% due to rounding up to 4,000.
- Deration is necessary to compensate for low atmospheric pressure at high altitudes. Generally this will require obtaining the gas heating value from the local gas utility and replacing the burner orifices.
- Low fire rates for 2-stage operation must also be verified.
- Table 2 lists the correct orifice size to use at different altitudes. See Installation Example 1 to determine the unit rating and orifice size.
- After changing the orifices, it is required that you measure the gas input rate by clocking the gas meter and using the local gas heating value. See Verifying & Adjusting the Firing Rate (page 4).

IMPORTANT NOTE: Observe the action of the burners to make sure there is no yellowing, lifting or flashback of the flame.

PRESSURE GAUGE INSTALLATION

For LP Gas installations: Refer to the unit rating plate to determine the incoming gas maximum and minimum inlet pressures. The incoming gas line pressure at the gas valve inlet must be between 11.0" WC and 14.0" WC.

IMPORTANT NOTE: If pressure testing the gas supply lines at pressures greater than 1/2 psig (14"WC), the unit must be disconnected from the gas supply piping system to prevent damage to the gas valve.

LIGHTING & ADJUSTMENT OF THE APPLIANCE

1. Turn ON the gas at the manual valve, outside of the unit.
2. Check all gas connections for leaks with a soap and water solution. If the solution bubbles, there is a gas leak which must be corrected. **DO NOT use an open flame to check for gas leaks.**
3. Turn ON the electrical power to the appliance.
4. Move the gas valve lever/switch/knob to the ON position. See Figure 2 (page 5). **NOTE:** The lever/knob must be moved to the end of its range of motion to insure the valve is completely open. Use only your hand to push in or turn the gas control valve. Never use tools.
5. Set the room thermostat to a point above room temperature to begin the heating cycle of the unit.
6. Check that the unit ignites and operates properly. Refer to the installation instructions provided with your unit for the normal operating sequence.
7. After the flame ignites, visually inspect the burner assembly to ensure that the flame is drawn directly into the center of the heat exchanger tube. The end of the flame will be out of sight around the bend of the heat exchanger tube. In a properly adjusted burner assembly, the flame color should be blue with some light yellow streaks near the outer portions of the flame.

NOTE: Until all of the air is bled out of the gas line, the spark ignitor may not ignite the gas. If the ignition control locks out, turn the thermostat to its lowest setting and wait one minute then turn the thermostat to a point above room temperature. The ignitor will try again to ignite the main burners. This process may have to be repeated several times before the burners will ignite. After the burners are lit, check all gas connections for leaks again with the soap and water solution. If the solution bubbles, there is a gas leak which must be corrected. Do not use an open flame to check for gas leaks.

VERIFYING & ADJUSTING FIRING RATE

The input firing rate must be verified for each installation to prevent over-firing of the unit.

CAUTION:

Do not re-drill the burner orifices. If the orifice size must be changed, use only new orifices.

IMPORTANT NOTE: The firing rate must not exceed the rate shown on the unit data label. At altitudes above 2,000 ft., it must not exceed that on the data label less 4% for each 1,000 ft. Follow the steps below to determine the unit firing rate:

- For installations at 2,000 feet and less, the firing rate is the same as shown on the unit rating label.
- For installations above 2,000 feet, calculate the correct firing rate as shown in Example 1.
- Table 2 (page 6) lists the correct orifice size to use at different altitudes. See Example 1 to determine the unit rating and orifice size.
- After changing the orifices, it is required that you measure the gas input rate by clocking the gas meter and using the local gas heating value. See Step 6 and Example 2 below.

- Observe the action of the burners. Make sure there is no yellowing, lifting or flashback of the flame.

WARNING:

The reduction of input rating necessary for high altitude installation may only be accomplished with factory supplied orifices. DO NOT attempt to drill out orifices in the field. Improperly drilled orifices may cause fire, explosion, carbon monoxide poisoning, personal injury or death.

1. Obtain the gas heating value from the gas supplier (HHV).
2. Verify that the gas supply line is at the correct supply pressure and that the supply pressure is within the allowable unit limits listed on the unit rating plate.
3. Shut off all other gas fired appliances.
4. Start the unit in heating mode and allow it to run for at least three minutes.
5. Using an in-line flow meter, measure the gas flow rate through the supply line to the unit. Convert the reading into cubic feet per hour. Refer to the meter manufacturer's instructions, or the gas supplier for more information.
6. Multiply the gas flow rate in cubic feet per hour by the heating value of the gas in Btu per cubic foot to obtain the firing rate in Btu per hour. See Example 2 below. **The Manifold pressure must be set to the appropriate value for your installation. Adjustments to the firing rate can be made by adjusting the gas manifold pressure.**

EXAMPLE 2:

- For a high fire flow rate of 68 cu. ft. gas per hour.
- Local heating value of LP gas (obtained from gas supplier) = 2,500 Btu per cu. ft.
- Input rate = 2,500 x 68 = 170,000 Btuh.

CHECKING THE MANIFOLD PRESSURE

The manifold pressure can be measured by installing a pressure gauge or U-tube manometer to the **OUTLET** end of the gas valve as follows:

1. Turn off all electrical power to the appliance.
2. Shut OFF the gas supply at the manual shutoff valve located outside of the appliance.
3. Using a 3/16" Allen wrench, remove the manifold pressure tap plug located on the outlet side of the gas valve. See Figure 2 (page 5).
4. Install an 1/8" NPT pipe thread fitting, that is compatible with a Manometer or similar pressure gauge.
5. Connect the Manometer or pressure gauge to the manifold pressure tap. Turn gas supply on at manual shutoff.
6. Set the room thermostat above room temperature to start the furnace.
7. Allow the unit to operate for 3 minutes and then check the manifold pressure. For LP gas installations, the manifold pressure should be set to approximately 9.5" WC. If the manifold pressure is not set to the appropriate pressure, then it must be adjusted.

ADJUSTING THE MANIFOLD PRESSURE

NOTE 1: The new valve LP regulator springs must be adjusted to the proper input firing rates or manifold settings. Both HIGH and LOW fire inputs should be checked. Always inspect the unit rating label to determine the correct (0-2,000 ft) factory setting. See Table 4 (page 6).

NOTE 2: The unit firing rate should be inspected for each installation as described in these instructions. The manifold pressure may be different than the factory setting. If the determination of the actual unit firing rate cannot be made with quality instruments, then the manifold pressure should be set to the factory setting shown on the unit rating label for installations between 0 & 2,000 ft.

White Rodgers Gas Valve Adjustment (12 1/2 - 15 Ton Units):

1. Remove the protective cap from the top of the High fire gas valve regulator as shown in the manufacturers instructions.
2. Set the manifold pressure to the factory settings, as shown on the unit rating label – or to the correct manifold pressure setting to obtain the correct firing rate.

NOTE: Turn the adjusting screw clockwise to increase pressure or counterclockwise to reduce pressure. To prevent the screw from backing all the way out from the valve, turn the screw slowly.

3. Replace the protective cap over the adjustment screws and tighten.

NOTE: The unit Low firing rate (Stage 1 only) should be approx. 65% of the unit High firing rate. (Stage 1 & 2) See Table 2.

From example 1 (page 3): The furnace high fire rating of 129,000 Btuh reduced for 4,000 ft. elevation, would have a low fire rating of 84,000 Btuh, or 0.65 x 129,000 Btuh.

4. Inspect the unit low firing rate in the same manner described in the instructions for Verifying & Adjusting Firing Rate section (Page 4).
5. Use the same procedure for the High fire adjustment described in steps 1-3 above to adjust the Low fire manifold pressure. If the firing rate cannot be determined, set the low fire manifold pressure to the factory setting as shown on the unit rating label, or refer to table 4.

REMOVING THE PRESSURE GAUGE U-TUBE MANOMETER

After the manifold pressure has been properly adjusted, the pressure gauge or U-tube manometer must be removed from the gas valve.

1. Turn the thermostat to its lowest setting.
2. Shut OFF the main gas supply to the unit at the manual shut-off valve, located outside of the unit.
3. Shut OFF all electrical supplies to the unit.
4. Remove the manometer adapter from the gas valve and replace it with the 1/8" NPT manifold pressure plug removed earlier. Verify the plug is sealed tightly and not cross threaded.
5. Turn ON all electrical power to the unit.
6. Turn ON the main gas supply to the unit at the manual shut-off valve, located outside of the unit.

COMPLETING THE CONVERSION

1. For all (*)R4(M,N) or R6GN-150 / 180 conversions to LP gas, affix the conversion warning label (#703935) provided in the kit to the outside of the units louvered burner access panel. Next, affix the conversion information label (#710005) over the Natural Gas warning label. Each label shall be prominent and visible after installation.
2. Affix the gas valve manufactures labels to the valve as described in the manufactures instructions.
3. Replace the unit's louvered burner access panel.
4. Run the appliance through a complete cycle to assure proper operation.

Model 36H64

P/N - 624695

IMPORTANT NOTE: When converting to LP/ Propane gas from natural gas, both springs from the gas valve must be replaced by the white springs included in the kit. The LP Propane springs for HIGH and LOW fire are the same size, shape, and color.

1. Remove both regulator cover screws. See Figure 3.
2. Remove both regulator adjustment screws from the gas valve (located beneath the cover screws).
3. Remove both Natural Gas regulator springs (color coded silver / Plain) from the regulator sleeves.
4. Install both L.P. regulator springs (provided in the conversion kit and color coded white) into the regulator sleeves.
5. Replace the HIGH regulator adjustment screw and adjust approximately 12 turns to the bottom stop.
6. Relace the LOW regulator adjustment screw and adjust approximately 8 turns.
7. Check and adjust both regulator settings (High and Low fire) to the firing rates listed in Table 3 for factory settings below 2,000 ft elevation or for reduced firing rates based on final high altitude calculations

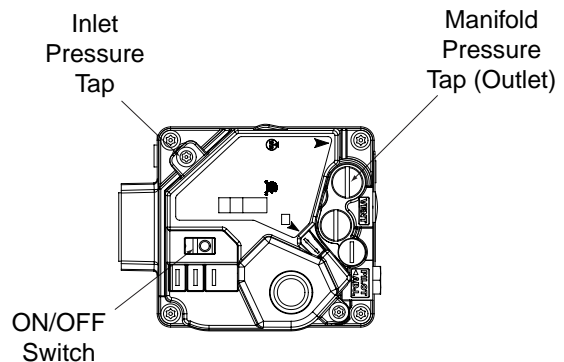

Model 36H64

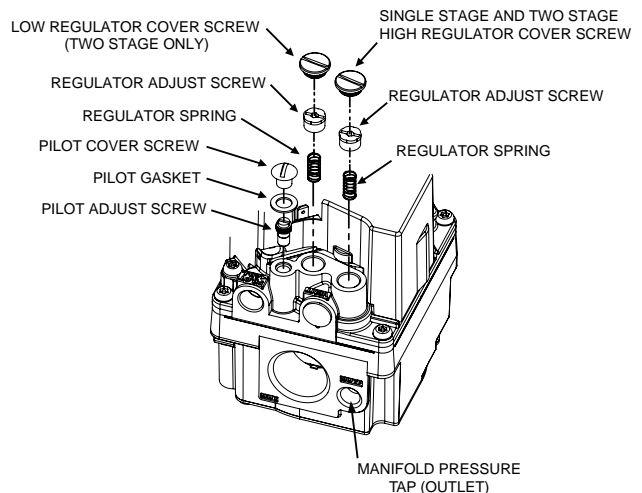

Figure 2. Two-Stage White Rodgers Gas Valve

Unit Model Number	Gas Type	Number of Burners	Gas Valve Manufacturer	2 Stage Heating Operation (Btu/Hr)				Orifice Size for Increased Elevation (Above Sea Level)			
				High Fire		Low Fire		0 to 2,000 Ft	2,001 FT to 4,000 Ft	4,001 FT to 6,000 Ft	6,001 FT to 7,000 FT
				Input	Output	Input	Output				
(*R4G(M,N) or R6GN-XXX*-180C	L.P.	4	White Rodgers	153,000	122,000	100,000	80,000	49	50	51	51
(*R4G(M,N) or R6GN-XXX*-270C		6		230,000	184,000	149,000	119,000	49	50	51	51
(*R4G(M,N) or R6GN-XXX*-315C		7		268,000	214,000	174,000	139,000	49	50	51	51

NOTE: Refer to Instructions for High Altitude Deration to determine heat-exchanger capacity at increased elevations.

Table 2. Orifice or Drill Size for Propane (LP) Gases

Unit Model Number	Gas Type	Heating Input (High Fire)	Heating Output (High Fire)	Heating Rise Range (°F)	CFM / Rise Range (1) - High Fire Data						
					4000	4300	4600	4900	5200	5600	SCFM
(*R4G(M,N) or R6GN-150 ^(†) -180C	L.P.	153,000	122,000	20 - 50	19	17	16	15	14	13	LF-Rise (° F)
					28	26	25	23	22	20	HF-Rise (° F)
					4000	4300	4600	4900	5200	5600	SCFM
(*R4G(M,N) or R6GN-150 ^(†) -270C		230,000	184,000	30 - 60	28	26	24	22	21	20	LF-Rise (° F)
					43	40	37	35	33	30	HF-Rise (° F)
					4800	5000	5200	5400	5700	6000	SCFM
(*R4G(M,N) or R6GN-180 ^(†) -270C		230,000	184,000	30 - 60	23	22	21	20	19	18	LF-Rise (° F)
					35	34	33	32	30	28	HF-Rise (° F)
					4800	5000	5200	5400	5700	6000	SCFM
(*R4G(M,N) or R6GN-180 ^(†) -315C		268,000	214,000	30 - 60	27	26	25	24	23	21	LF-Rise (° F)
					41	40	38	37	35	33	HF-Rise (° F)

NOTE: (1) Temperature rise data is approximate and based on unit installations of 2,000 feet or less.
LF=Low Fire, HF=High Fire

Table 3. Heating Rise / Range

Unit Model Number	Gas Valve Manufacturer	Gas Valve Model No.	Maximum Inlet Pressure ^(†)	Minimum Inlet Pressure ^(†)	Factory Set Manifold Pressure ^(†) High Fire	Factory Set Manifold Pressure ^(†) Low Fire
(*R4G(M,N) or R6GN-XXX*-180C	White Rodgers	36H64	14.0 (3.49)	11.0 (2.74)	9.5 (2.37)	5.0 (1.24)
(*R4G(M,N) or R6GN-XXX*-270C						
(*R4G(M,N) or R6GN-XXX*-315C						

NOTE: † Pressure values are expressed in: in-WC (kPa)

Table 4. Unit / Valve data - LP gas only

NORDYNE
COMPLETE COMFORT. GENUINE VALUE.

Specifications & illustrations subject to change without notice or incurring obligations.
O' Fallon, MO | Printed in U.S.A. (12/12)



708393A (Replaces 7083930)