

H5HK Series

Installation Instructions

3 Phase Electric Heater Kits

Light Commercial Package A/C and Heat Pump Systems

Description

Installation of 208/240V and 480V H5HK 3 Phase Heater Kits in 6, 7.5 and 10 Ton Packaged Air Conditioners and Heat Pumps.

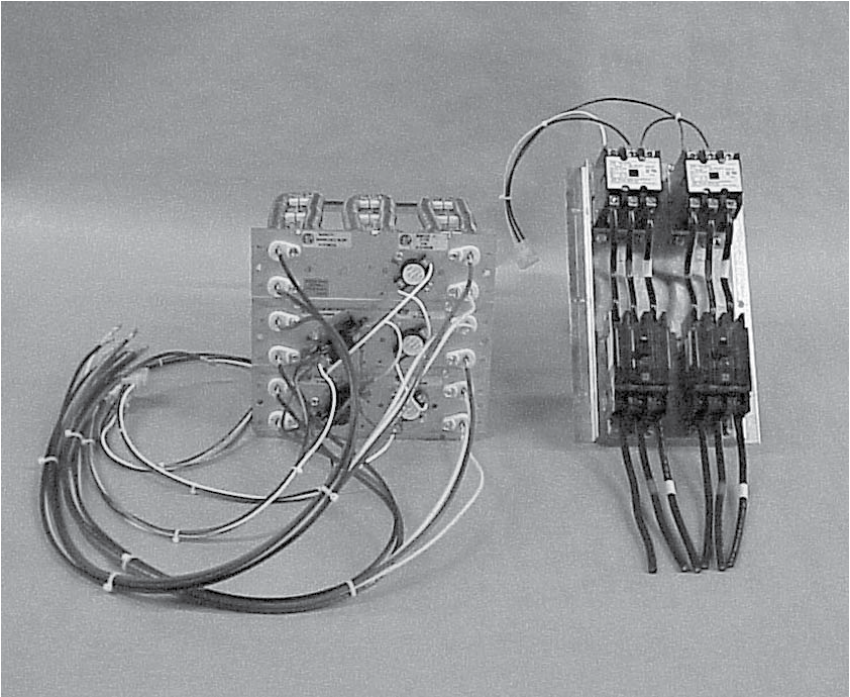

These instructions are primarily intended to assist qualified individuals experienced in the proper installation of heating and/or air conditioning appliances. Some local codes require licensed installation/service personnel for this type of equipment. All installations must be in accordance with these instructions and with all applicable national and local codes and standards.

Read these instructions thoroughly before starting the installation. Follow all precautions and warnings contained within these instructions and on the unit.

Improper installation, service, adjustment, or maintenance can cause explosion, fire, electrical shock, or other conditions which may result in personal injury or property damage. Unless otherwise noted in these instructions, only factory authorized kits or accessories may be used when working with these products.

GENERAL INFORMATION

H5HK Heater Kits are approved for use in the packaged Air Conditioners and Packaged Heat Pumps as listed when applied and installed according to these instructions. See Table 1 for the approved H5HK combinations. Refer to the National Electric Code (ANSI/NFPA 70) or in Canada the Canadian Electric Code Part 1 (CSA C.22.1) and applicable local codes for over-current protection and disconnect requirements.

If any of the original wiring as supplied with the unit must be replaced, it must be replaced with material of the same gauge and temperature rating.

ELECTRICAL SUPPLY

 **WARNING:**

To avoid the risk of electric shock, personal injury, or death, disconnect all electrical power to the unit before performing any maintenance or service. The unit may have more than one electrical power supply.

If the unit was previously installed without electric heat, the existing supply wiring may not be sufficient to handle the increased load. See the unit ratings label in Table 2 for minimum circuit ampacities and maximum over-current protection ratings. The units with installed electric heat may be supplied by a single circuit or dual circuits. An additional accessory kit is required if dual electrical circuit installation is desired. See Table 1 for accessory description and part number.

INSTALLATION PREPARATIONS

Before proceeding with the electrical connections, make certain that the voltage, frequency, and phase of the supply source are the same as those specified on the unit rating label. Also verify that the service provided by the utility is sufficient to handle the additional load imposed by this equipment.

CIRCUIT OPTIONS

Units installed with electric heat may be wired for single or multiple circuit supply connections.

Single Circuit - Units are factory ready for addition of heater kits. See unit rating label for Minimum Circuit Ampacity and Maximum OverCurrent Protection of supply wiring.

Multiple Circuit - For Dual Electrical Supply connections see the unit rating plate or Table 2, Electrical Data for proper high voltage wiring requirements. Use NORDYNE P/N-917468, 3 Pole Dual Circuit Adaptor for converting to dual supply connections. Refer to the instructions included with the 3 Pole Dual Circuit Adaptor kit for details on how to configure the adaptor for proper Cooling operation hookup.

NOTE: Circuit Breakers installed in the unit with the addition of heater kits are for short circuit protection of the internal heater element circuit wiring and DO NOT serve as a disconnect. The circuit breakers DO NOT provide over-current protection of the supply wiring.

Note:

Circuit Breakers included with kits are for heater kit short circuit protection ONLY and are not to be used as a disconnect means.

Unit Information		H5HK Heater Kit Information						
Capacity	Model	Part #	Model	Voltage	kW	Breakers	W.D.	Limit *
-090C	(*)P4S(M,N)	917423(A)	009Q-01	208 / 240	6.8 / 9.0	0	Fig. 3	160°F
		917424(A)	018Q-11		13.1 / 17.4	1	Fig. 4	160°F
		917425(A)	035Q-22		26.2 / 34.8	2	Fig. 5	210°F
-090D	(*)P4S(M,N)	917426(A)	018S-01	480	18	0	Fig. 7	160°F
		917427(A)	035S-01		34.8	0	Fig. 8	210°F
-120C	(*)P4S(M,N)	917423(A)	009Q-01	208 / 240	6.8 / 9.0	0	Fig. 3	160°F
		917424(A)	018Q-11		13.1 / 17.4	1	Fig. 4	160°F
		917425(A)	035Q-22		26.2 / 34.8	2	Fig. 5	160°F
-120D	(*)P4S(M,N)	917426(A)	018S-01	480	18	0	Fig. 7	160°F
		917427(A)	035S-01		34.8	0	Fig. 8	160°F

Unit Information		H5HK Heater Kit Information						
Capacity	Model	Part #	Model	Voltage	kW	Breakers	W.D.	Limit *
-072C	P6SP	917423A	009Q-01	208 / 240	6.8 / 9.0	0	Fig. 3	160°F
		917424A	018Q-11		13.1 / 17.4	1	Fig. 4	160°F
		920614	030Q-22		21.6 / 28.8	2	Fig. 5	180°F
-072D	P6SP	920616	009S-01	480	9.9	0	Fig. 6	155°F
		917426A	018S-01		18	0	Fig. 7	160°F
		920615	030S-01		28.8	0	Fig. 8	180°F
-090C	Q5SN P6SP Q6SP	917423A	009Q-01	208 / 240	6.8 / 9.0	0	Fig. 3	160°F
		917424A	018Q-11		13.1 / 17.4	1	Fig. 4	160°F
		920614	030Q-22		21.6 / 28.8	2	Fig. 5	180°F
		917425A	035Q-22		26.2 / 34.8	2	Fig. 5	210°F
-090D	Q5SN P6SP Q6SP	920616	009S-01	480	9.9	0	Fig. 6	155°F
		917426A	018S-01		18	0	Fig. 7	160°F
		920615	030S-01		28.8	0	Fig. 8	180°F
		917427A	035S-01		34.8	0	Fig. 8	210°F
-120C	Q5SN P6SP Q6SP	917423A	009Q-01	208 / 240	6.8 / 9.0	0	Fig. 3	160°F
		917424A	018Q-11		13.1 / 17.4	1	Fig. 4	160°F
		920614	030Q-22		21.6 / 28.8	2	Fig. 5	180°F
		917425A	035Q-22		26.2 / 34.8	2	Fig. 5	210°F
-120D	Q5SN P6SP Q6SP	920616	009S-01	480	9.9	0	Fig. 6	155°F
		917426A	018S-01		18	0	Fig. 7	160°F
		920615	030S-01		28.8	0	Fig. 8	180°F
		917427A	035S-01		34.8	0	Fig. 8	210°F

3-Pole, Dual Circuit Adapter Kit	Part # 917468
H5HK Series, High Static Application Kit	Part # 920998

* 210°F Limits are included w/ kit & require field installation.

Table 1. Heater Kit Applications

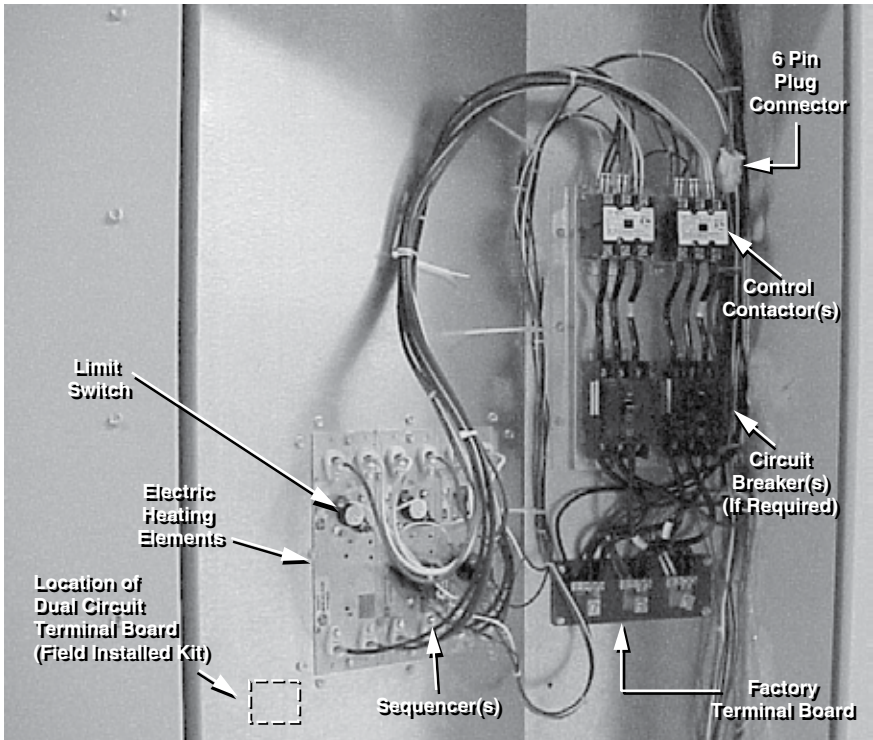

Figure 1a. Location of Typical Major Components

Whether or not circuit breakers are used in the units, over-current protection must be provided at the branch circuit distribution panel and sized as shown on the unit rating label or Table 2 and according to the National Electrical Code, Canadian Electrical Code, and applicable local codes.

TERMINAL BLOCKS

Approved H5HK heater kits are shipped ready to install using single circuit electrical supply and existing factory installed unit terminal block. If dual circuit supply is desired, follow instructions included in adaptor kit and install in lower left corner of element mounting panel using holes provided.

NOTE: Use of the 3 pole adaptor is for the unit's Refrigerant Cooling and Heat Pump circuit only.

This circuit includes:

- Compressors
- Blower motors
- OD fan motors
- Low Voltage transformer
(all unit electrical loads)

ELEMENT INSTALLATION

⚠ WARNING:

Rooftop installations with vertical ducts must be provided with a 90-degree elbow installed in the supply duct to comply with U. L. (Underwriters Laboratories) codes for use with electric heat so the elements are not directly over a supply grille.

⚠ WARNING:

Heaters may not function properly if elements are not installed per these instructions.

IMPORTANT: Application of H5HK-035Q and H5HK-035S Electric Heat Kits.

The three (3)- 160 Deg. F High Temperature limits installed on the element assembly must be replaced with the three (3)- 210 Deg. F High Temperature limits supplied with the electric heat kit on all 7.5 Ton package Air Conditioners and 7.5 & 10 Ton Q5, Q6 & P6 Package units. Ensure all wiring and connections are to unit wiring diagram when complete. Short cycling of equipment will occur if proper limits are not installed. (See table 1 for proper limit application).

Remove Element/Field Wiring Access panel.

***P4S(M,N) Series** – Determine the number of element close-off plates to be removed from mounting panel based on size of kit being installed. Set screws aside for later use and discard close-off plates.

P6SP/Q6SP/Q5SN Series – Remove the element opening cover. Four (4) mounting plates are required around the element kit to secure and seal the opening. Mount the longer plates to the top and bottom of the element assembly prior to inserting into the unit. Secure the element assembly in place using screws removed with the cover. Attach the remaining two side close

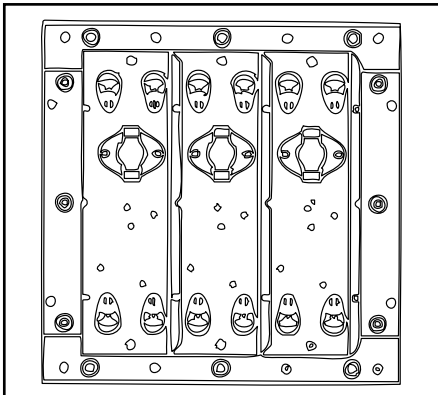

Figure 1B. Mounting Plates

off plates. **NOTE:** 240V -009Q and -018Q kits require the addition of a blank element plate included in the kit. See Figure 1B.

⚠ WARNING:

Install heater elements starting closest to the blower with high temperature limits located at the top of the assembly. See Figure 1A. Be careful not to damage heater element wires or ceramic element supports while inserting through panel opening. Ensure heater element support rods slide into the alignment holes in the back of the element housing box. Secure the element assembly to the mounting panel with the screws removed when removing the element close-off plates.

CONTROL MOUNTING

Electric Heater Kits without Circuit Breakers

Three pole control contactors locate on the element mounting panel above the factory installed terminal block. See Figure 2 for location of the two (2) mounting holes required for kit power wiring to be of proper length. Mount contactor with screws provided in kit.

Electric Heater Kits with Circuit Breakers

NOTE: Circuit Breakers supplied with the H5HK electric heater kits are for short circuit-protection of the heater element internal wiring and DO NOT serve as a disconnect. Circuit Breakers supplied with the H5HK heater kits DO NOT provide over-current protection of the supply wiring. Over-current protection of the supply wiring must be provided at the distribution panel and sized as shown on the unit rating label or in Table 2 of these instructions.

Contactor/Circuit Breaker control panel is shipped fully assembled for mounting above the factory installed terminal block using the six (6) mounting holes provided. See Figure 2 for layout location and mount panel with screws provided in kit.

ELEMENT POWER WIRING

Elements are shipped with element power wiring ready for attachment to top terminals of the three (3) pole control contactors. Connect the two (2) – BLACK w/WH, two (2) – RED w/BK, and two (2) – Yellow w/BK wires to the corresponding T1, T2, and T3 terminals of the contactor.

NOTE: H5HK-030 & 035Q models only - 240 Volt, 30 and 35 Kw kits supplied with two sets of six (6) element power wires - the second set of wires will connect to the second or top right control contactor. Connect the two (2) BLACK w/WH, two (2) – RED w/BK, and two (2) – Yellow w/BK wires to the corresponding T1, T2, and T3 terminals of this second contactor.

Complete the power wiring connections for all kits by attaching the supplied Black, Red, and Yellow or (Black with Yellow markings) from the bottom of the three (3) pole contactors on –009Q, –018S, and –035S models or from the bottom of the Circuit Breakers on –018Q and –035Q models. Connect Black, Red, and Yellow to Lines L1, L2, and L3 respectively.

Refer to the specific detailed wiring diagram for all final connections. Make sure all connections are secure.

NOTICETO INSTALLER - Mark the appropriate box on the unit rating label with a permanent “X” to indicate which heater kit has been installed.

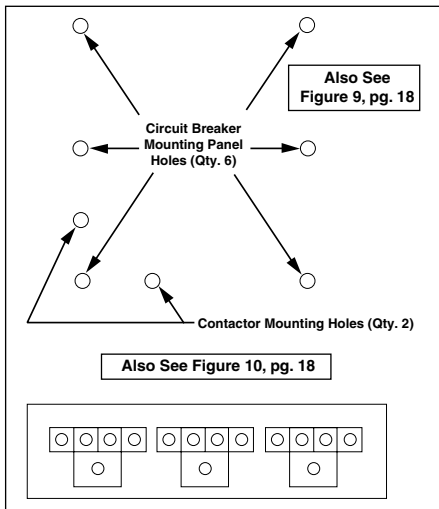

Figure 2. Control Mounting Location

Low Voltage Control Wiring

Connect the heater kit six (6) pin plug connector to the units mating plug receptacle located in the upper right hand side of the heater element control compartment. Make sure the connection is secure.

Complete the low voltage connections by joining the three (3) pin plug and receptacle connectors shipped as part of the heater kit assembly. Make sure the connection is secure.

Wiring Diagrams -Wiring Diagrams are shipped with each H5HK Heater kit assembly. Attach the wiring diagram in plain view on the heater element mounting panel. Make sure surface is clean and oil free before applying.

AIRFLOW

The maximum external static pressure (ESP) for the unit is listed on the unit rating label.

IMPORTANT: High Static Applications of the H5HK 30 kW & 35 kW kits.

When installing the 30 kW & 35 kW H5HK Heater kits in the Q5/Q6 series packaged heat pumps and in conjunction with a high static drive kit; or on duct systems where the unit ESP is greater then 0.75 in-W.C. for the 7.5T units or 0.9 in-W.C. for 10T units; then the heater kit will require an additional accessory kit. See Table 1 for accessory description and part number.

The blower speed is preset at the factory for optimum operation in Heating and Cooling modes. It may be necessary for some applications to change the factory set speed. To change the blower speed see the “Blower Speed” section in the Installation Instructions shipped with the unit.

If a lower blower speed is desired, then the heater element high temperature limits must be checked for proper operation. Nuisance tripping and cycling of the limits may result with too little of airflow. Limit operation should be checked with return air temperatures between 72 F and 78 F.

If a higher blower speed is desired from the factory then no other modifications are required.

CLEARANCE

All H5HK Electric Heater kits are approved for use in installations with zero-clearance to combustibles at any blower speed allowed on the units blower performance charts for both Horizontal and Downflow applications when

installed according to these instructions and other instructions included with the unit and other approved accessories. (See warning for downflow applications in Element Installation section, page 5)

Heater Kit Electrical Data @ Rated Voltage 3 Phase, 60 Hertz				Multiple Circuit "B" †	
Rated Volts	Model Number	Line Amps	Heater Watts	Minimum Circuit Ampacity	Maximum Over-Current Rating
208V	H5HK-009Q	18.8	6,760	24	25
	H5HK-018Q	36.3	13,069	46	50
	H5HK-030Q	60.0	21,632	76	80
	H5HK-035Q	72.6	26,139	91	100
240V	H5HK-009Q	21.7	9,000	28	30
	H5HK-018Q	41.9	17,400	53	55
	H5HK-030Q	69.3	28,800	87	90
	H5HK-035Q	83.7	34,800	105	110
480V	H5HK-009S	11.9	9,900	15	20
	H5HK-018S	21.7	18,000	28	30
	H5HK-030S	34.6	28,800	44	45
	H5HK-035S	41.9	34,800	53	55

† When used with 917468 kit, See applicable unit chart for Multiple Circuit "A" data

‡ Refer to Table 1 for allowable unit / H5HK combinations

Table 2. Electrical Data - H5HK Series Heater Kits

Unit Model	Heater Kit Electrical Data				Multiple Circuits					
	Model Number	Rated Volts	Phase	Kw	Single Circuit		Circuit A (Cooling)		Circuit B (Heating)	
					Minimum Circuit Ampacity	Maximum Over-Current Rating	Minimum Circuit Ampacity	Maximum Over-Current Rating	Minimum Circuit Ampacity	Maximum Over-Current Rating
(*)P4S(M/N)-090C 7.5 Ton Package A/C 208/230V, 3 Phase	No Kit	---	---	---	42.2	60	---	---	---	---
	H5HK-009Q	208/240	3	9	42.2	60	---	---	---	---
	H5HK-018Q	208/240	3	17.4	60.2	70	42.2	60.0	52.3	60.0
	H5HK-035Q	208/240	3	34.8	112.5	125	42.2	60.0	104.6	110.0
(*)P4S(M/N)-090D 7.5 Ton Package A/C 460V, 3 Phase	No Kit	---	---	---	21.2	30	---	---	---	---
	H5HK-018S	480	3	18	30.9	40	21.2	30.0	27.1	30.0
	H5HK-035S	480	3	34.8	56.2	60	21.2	30.0	52.3	60.0
(*)P4S(M/N)-120C 10 Ton Package A/C 208/230V, 3 Phase	No Kit	---	---	---	61.3	90	---	---	---	---
	H5HK-009Q	208/240	3	9	61.3	90	---	---	---	---
	H5HK-018Q	208/240	3	17.4	63.7	90	---	---	---	---
	H5HK-035Q	208/240	3	34.8	116.0	125	61.3	90.0	104.6	110.0
(*)P4S(M/N)-120D 10 Ton Package A/C 460V, 3 Phase	No Kit	---	---	---	27.2	40	---	---	---	---
	H5HK-018S	480	3	18	32.6	40	---	---	---	---
	H5HK-035S	480	3	34.8	57.8	60	27.2	40.0	52.3	60.0

Table 2a. Electrical Data - Package A/C - P4 Units

Model Number	Allowable Voltage Range		Compressors		Outdoor motors (2) ea.	Indoor Motor	Mult. Circ. "A" †		Single Circuit - P6SP & H5HK kit								
	Min	Max	Qty	RLA			FLA	FLA	FLA	No Heater Kit	MCA			MOP			
Factory Drive Data:																	
P6SP	187	253	1 ea.	19	123	1.5	3.2 - 3.1	30 - 30	45 - 45	9 kW	18 kW	30 kW	35 kW	9 kW	18 kW	30 kW	35 kW
-072 C	187	253	1 ea.	19	123	1.5	3.2 - 3.1	30 - 30	45 - 45	30 - 31	50 - 57	80 - 91	- n/a -	45 - 45	55 - 60	90 - 100	- n/a -
-072 D	414	506	1 ea.	9.7	62	0.8	1.5	16	20	17	29	46	- n/a -	20	30	50	- n/a -
-090 C	187	253	2 ea.	13.1	83.1	2.3	6.2 - 5.8	41 - 40	50 - 50	41 - 40	54 - 60	83 - 94	99 - 112	50 - 50	55 - 70	90 - 100	100 - 125
-090 D	414	506	2 ea.	6.1	41	1.2	2.9	19	25	19	31	47	56	25	35	50	60
-120 C	187	253	2 ea.	16.0	110	2.3	6.2 - 5.8	47 - 47	60 - 60	47 - 47	54 - 60	83 - 94	99 - 112	60 - 60	60 - 70	90 - 100	100 - 125
-120 D	414	506	2 ea.	7.8	52	1.2	2.9	23	30	23	31	47	56	30	35	50	60
Medium Static Drive Data:																	
-072 C	187	253	1 ea.	19	123	1.5	4.4 - 4.2	32 - 31	50 - 45	32 - 33	51 - 58	81 - 92	- n/a -	50 - 45	60 - 60	90 - 100	- n/a -
-072 D	414	506	1 ea.	9.7	62	0.8	2.1	16	25	18	30	46	- n/a -	25	35	50	- n/a -
-090 C	187	253	2 ea.	13.1	83.1	2.3	9.1 - 8.9	44 - 43	55 - 55	44 - 43	57 - 64	87 - 98	103 - 116	55 - 55	60 - 70	90 - 100	100 - 125
-090 D	414	506	2 ea.	6.1	41	1.2	4.4	21	25	21	33	49	58	25	35	50	60
-120 C	Not Applicable																
-120 D	Not Applicable																
High Static Drive Data:																	
-072 C	Not Applicable																
-072 D	Not Applicable																
-090 C	187	253	2 ea.	13.1	83.1	2.3	9.1 - 8.9	44 - 43	55 - 55	44 - 43	57 - 64	87 - 98	103 - 116	55 - 55	60 - 70	90 - 100	100 - 125
-090 D	414	506	2 ea.	6.1	41	1.2	4.4	21	25	21	33	49	58	25	35	50	60
-120 C	187	253	2 ea.	16.0	110	2.3	9.1 - 8.9	50 - 50	60 - 60	50 - 50	57 - 64	87 - 98	103 - 116	60 - 60	60 - 70	90 - 100	100 - 125
-120 D	414	506	2 ea.	7.8	52	1.2	4.4	25	30	25	33	49	58	30	35	50	60

Notes: FLA = Full Load Amps
 RLA = Rated Load Amps
 LRA = Locked Rotor Amps
 MCA = Minimum Circuit Ampacity
 MOP = Maximum Over-Current Protection
 C Series, Electrical unit data shown for 208V - 230V
 D Series, Electrical unit data shown for 460V

† When used with 917468 Dual Circuit Adapter Kit - See Table 2 for Multiple Circuit "B" data

Table 2b. Electrical Data - Packaged A/C - P6 Units - 3 Phase, 60 Hertz

Model Number	Allowable Voltage Range		Compressors		Outdoor motors (2) ea.	Indoor Motor	Mult. Circ. "A" †		Single Circuit - Q5SN & H5HK kit														
	Min	Max	Qty	RLA			LRA	FLA	FLA	No Heater Kit	MCA	MOP	MCA							MOP			
Factory Drive Data:																							
Q5SN	187	253	2 ea.	12.8	91	2.3	4.2 - 4.0	38 - 38	50 - 50	49 - 52	71 - 77	100 - 112	116 - 130	55 - 55	80 - 80	110 - 125	125 - 150						
-090 C	414	506	2 ea.	6.4	46	1.2	2.0	19	25	28	40	56	65	30	45	60	70						
-120 C	187	253	2 ea.	15.4	124	2.3	6.2 - 5.8	46 - 46	60 - 60	54 - 57	76 - 82	106 - 117	121 - 135	60 - 60	80 - 90	110 - 125	125 - 150						
-120 D	414	506	2 ea.	7.4	59.6	1.2	2.9	22	25	30	42	58	67	35	45	60	70						
High Static Drive Data:																							
-090 C	187	253	2 ea.	12.8	91	2.3	9.1 - 8.9	43 - 43	55 - 55	54 - 57	75 - 82	105 - 117	121 - 135	60 - 60	80 - 90	110 - 125	125 - 150						
-090 D	414	506	2 ea.	6.4	46	1.2	4.4	22	25	30	42	59	68	35	45	60	70						
-120 C	187	253	2 ea.	15.4	124	2.3	9.1 - 8.9	49 - 49	60 - 60	57 - 60	79 - 86	108 - 120	124 - 138	60 - 70	80 - 90	110 - 125	125 - 150						
-120 D	414	506	2 ea.	7.4	59.6	1.2	4.4	24	30	31	44	60	69	35	45	70	70						

Table 2c. Electrical Data - Packaged H/P - Q5 Units - 3 Phase, 60 Hertz

Model Number	Allowable Voltage Range		Compressors		Outdoor motors (2) ea.	Indoor Motor	Mult. Circ. "A" †		Single Circuit - Q6SP & H5HK kit									
	Min	Max	Qty	RLA			LRA	FLA	FLA	MCA	MOP	9 kW	18 kW	30 kW	35 kW	9 kW	18 kW	30 kW
Factory Drive Data:																		
Q6SP	187	253	2 ea.	13.1	83.1	2.3	4.2 - 4.0	FLA	No Heater Kit	9 kW	18 kW	30 kW	35 kW	9 kW	18 kW	30 kW	35 kW	35 kW
-090 C	187	253	2 ea.	6.1	41	1.2	2.0	FLA	39 - 39	50 - 50	49 - 52	71 - 78	101 - 112	116 - 130	55 - 55	80 - 80	110 - 125	125 - 150
-090 D	187	253	2 ea.	15.6	110	2.3	6.2 - 5.8	FLA	19	20	27	40	56	65	30	45	60	70
-120 C	187	253	2 ea.	7.8	52	1.2	2.9	FLA	46 - 46	60 - 60	54 - 57	76 - 83	106 - 117	121 - 135	60 - 60	80 - 90	110 - 125	125 - 150
-120 D	187	253	2 ea.	7.8	52	1.2	2.9	FLA	23	30	30	43	59	68	35	45	60	70
High Static Drive Data:																		
-090 C	187	253	2 ea.	13.1	83.1	2.3	9.1 - 8.9	FLA	44 - 44	55 - 55	54 - 57	76 - 83	106 - 117	121 - 135	60 - 60	80 - 90	110 - 125	125 - 150
-090 D	187	253	2 ea.	6.1	41	1.2	4.4	FLA	21	25	30	42	58	67	35	45	60	70
-120 C	187	253	2 ea.	16.0	110	2.3	9.1 - 8.9	FLA	49 - 49	60 - 60	57 - 61	79 - 86	109 - 120	124 - 138	60 - 70	80 - 90	110 - 125	125 - 150
-120 D	187	253	2 ea.	7.8	52	1.2	4.4	FLA	25	30	32	44	60	69	35	45	60	70

Table 2d. Electrical Data - Packaged H/P - Q6 Units - 3 Phase, 60 Hertz

Notes: FLA = Full Load Amps
 RLA = Rated Load Amps
 LRA = Locked Rotor Amps
 MCA = Minimum Circuit Ampacity
 MOP = Maximum Over-Current Protection
 C Series, Electrical unit data shown for 208V - 230V
 D Series, Electrical unit data shown for 460V

† When used with 917468 Dual Circuit Adapter Kit - See Table 2 for Multiple Circuit "B" data

Table 2d. Electrical Data - Packaged H/P - Q6 Units - 3 Phase, 60 Hertz

NOTES:

1. If any of the original wire supplied with this unit must be replaced, it must be replaced with wiring material of the same gauge size and temperature rating.
2. The installation of this heater kit may require a change in the blower speed. See Installation Instructions for details.
3. Use copper conductors with minimum temperature rating of 60C for supply connections.

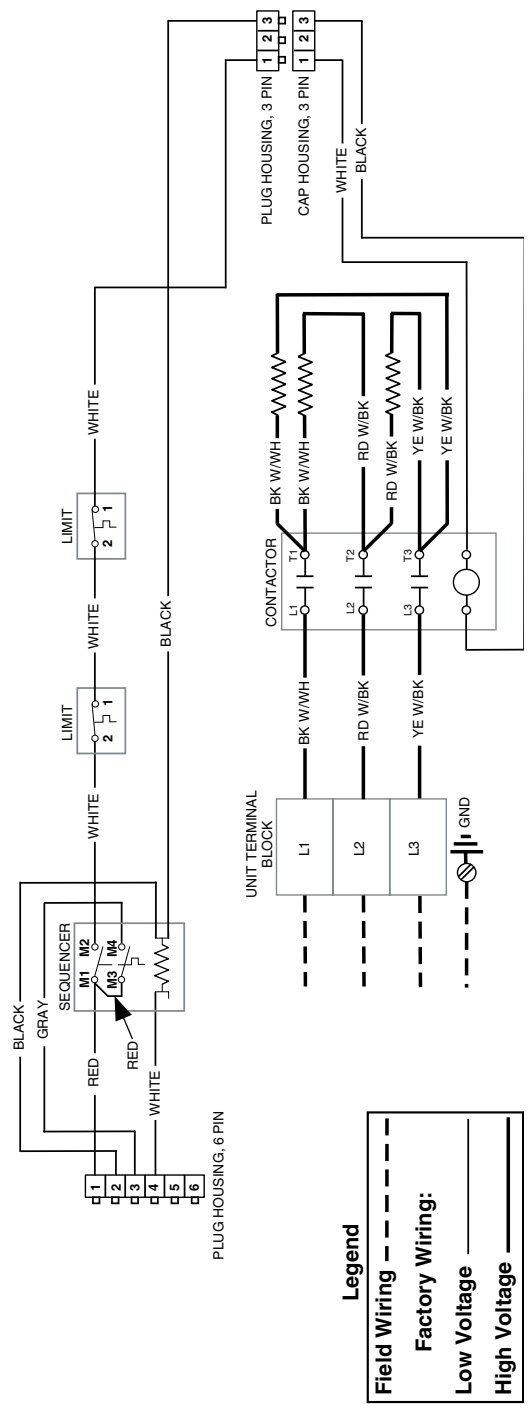

710098A

Figure 3. Wiring Diagram 9 kw, 1-Stage, 240 VAC

NOTES:

1. Circuit breakers may not be wired to heater kit by the factory, see Installation Instructions for wiring procedure.
2. If any of the original wire supplied with this unit must be replaced, it must be replaced with wiring material of the same gauge size and temperature rating.
3. The installation of this heater kit may require a change in the blower speed. See Installation Instructions for details.
4. Use copper conductors with minimum temperature rating of 60C for supply connections.

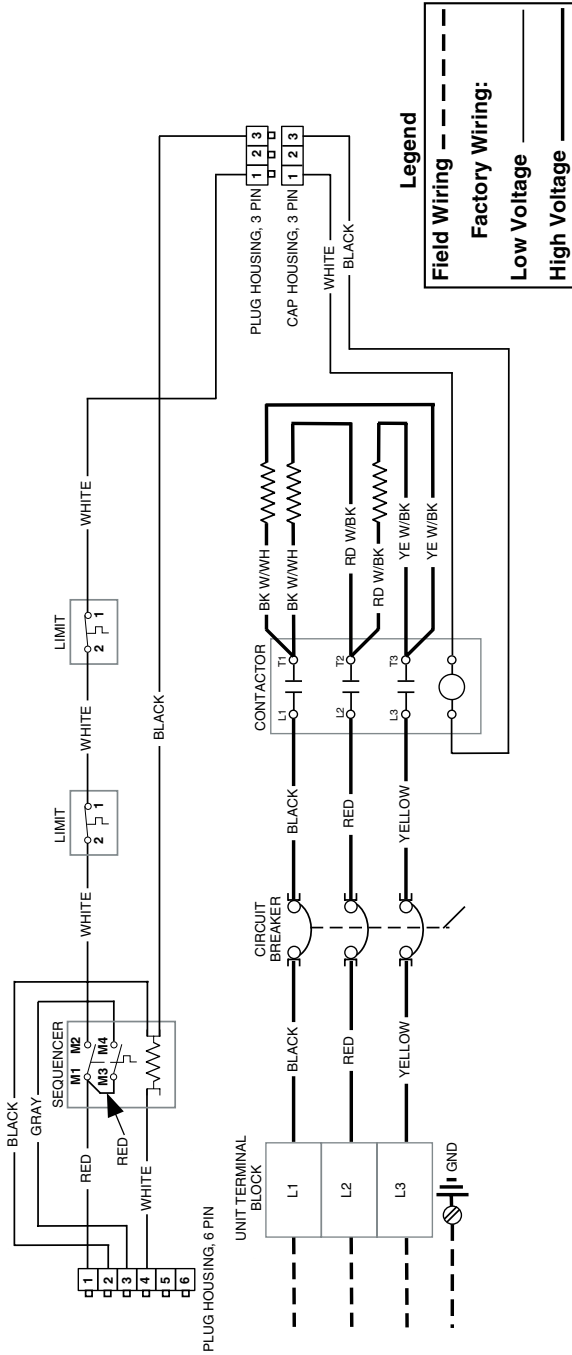

Figure 4. Wiring Diagram 18 kw, 1-Stage, 240 VAC

710099A

H5HK030Q-22 & H5HK035Q-22

30KW & 35KW, 1-STAGE, 208/240 VAC, 3-PHASE HEATER KIT

NOTES:

1. Circuit breakers may not be wired to heater kit by the factory, see Installation Instructions for wiring procedure.
2. If any of the original wire supplied with this unit must be replaced, it must be replaced with wiring material of the same gauge size and temperature rating.
3. Use copper conductors with minimum temperature rating of 60c for supply connections.

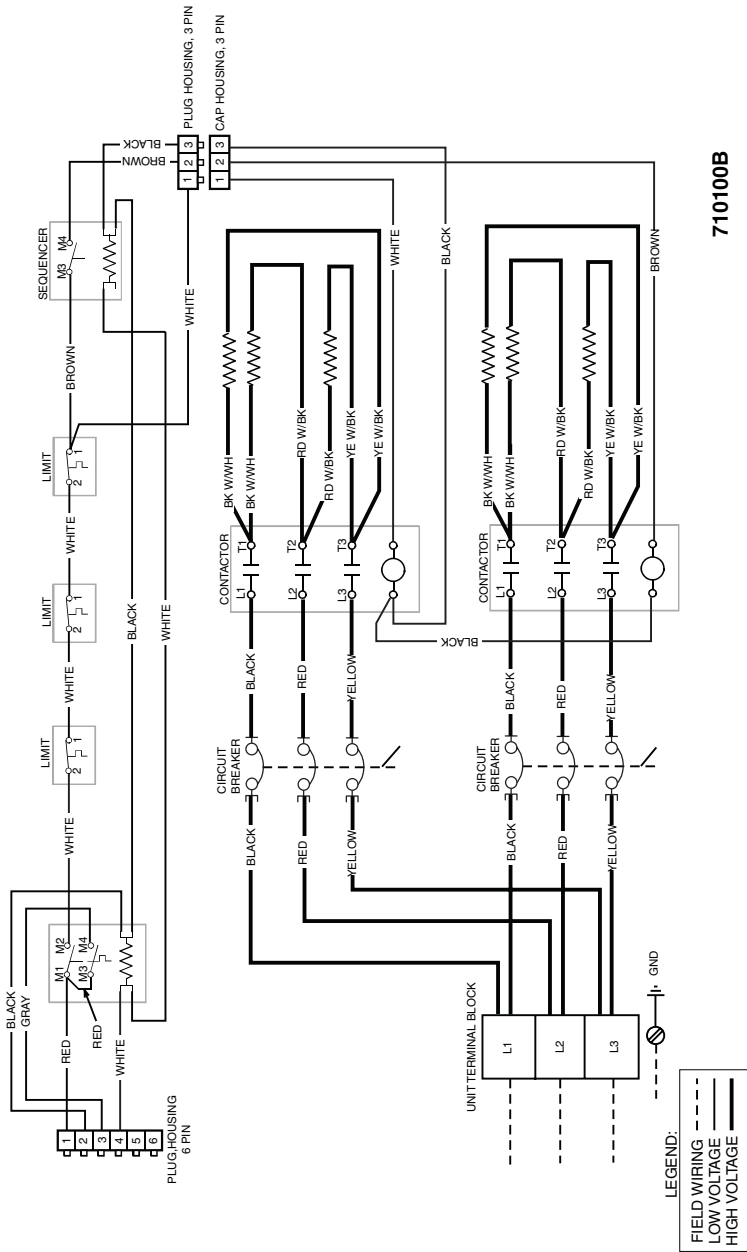

710100B

Figure 5. Wiring Diagram 30 & 35 kw, 1-Stage, 240 VAC

H5HK009S-01

480V-3Ph-60HZ

9KW,1-STAGE,ELECTRIC HEATER KIT

NOTES:

1. if any of the original wire supplied with this unit must be replaced, it must be replaced with wiring material of the same gauge size and temperature rating.
2. The installation of this heater kit may require a change in the blower speed. See unit installation instructions for details.
3. Use copper conductors with minimum temperature rating of 60C for supply connections.

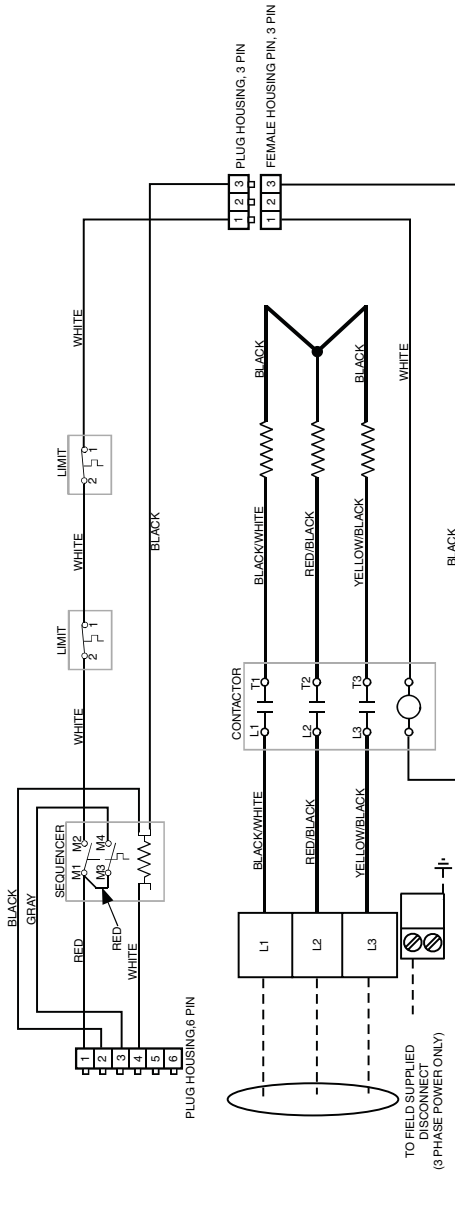
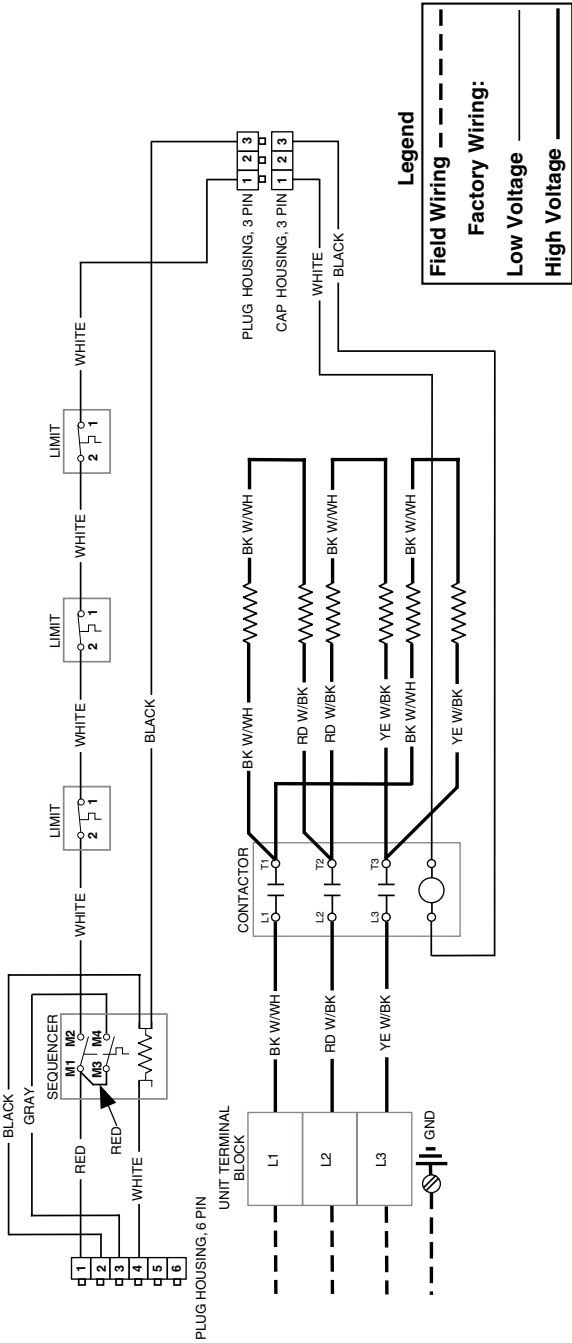

Figure 6. Wiring Diagram 9 kw, 1-Stage, 480 VAC

7108680

NOTES:

1. If any of the original wire supplied with this unit must be replaced, it must be replaced with wiring material of the same gauge size and temperature rating.
2. The installation of this heater kit may require a change in the blower speed. See Installation Instructions for details.
3. Use copper conductors with minimum temperature rating of 60C for supply connections.



710101A

Figure 7. Wiring Diagram 18 kw, 1-Stage, 480 VAC

H5HK030S-01 & H5HK035S-01

30KW & 35KW, 1-STAGE, 480 VAC, 3-PHASE HEATER KIT

NOTES:

1. If any of the original wire supplied with this unit must be replaced, it must be replaced with wiring material of the same gauge size and temperature rating.
2. The installation of this heater kit may require a change in the blower speed. See Installation Instructions for details.
3. Use copper conductors with minimum temperature rating of 60c for supply connections.

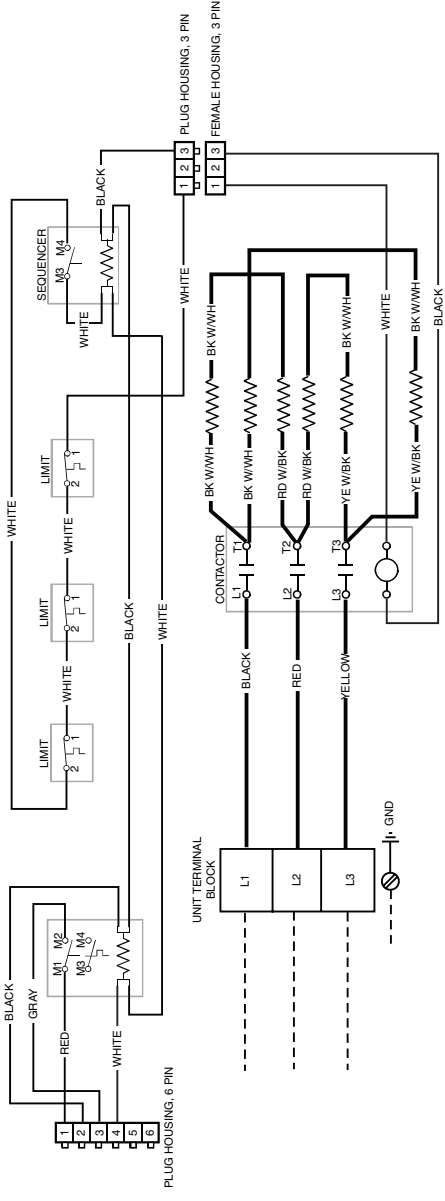

LEGEND:

- FIELD WIRING - - - - -
- LOW VOLTAGE ————
- HIGH VOLTAGE ————

710102B

Figure 8. Wiring Diagram 30 & 35 kw, 1-Stage, 480 VAC

REPLACEMENT PARTS LIST

Heater P/N
 917423A
 917424A
 920614
 917425A
 920616
 917426A
 920615
 917427A

Item	PN	Description	V		208-240				480				
			kW	9	18	30	35	9	18	30	35		
1	491216	Element Ass'y - 3.0 kW		1									
	D12698	Element Ass'y - 3.3 kW							1				
	175160	Element Ass'y - 5.8 kW			1								
	491227	Element Ass'y - 6.0 kW		1						3			
	D12708	Element Ass'y - 6.6 kW							1				
	491225	Element Ass'y - 9.6 kW					3				3		
	498193	Element Ass'y - 11.6 kW			1		3						3
2	621380	Sequencer, 2-pole, Blower Timing		1	1	1	1		1	1	1	1	1
	621383	Sequencer, 1-pole, Auxiliary Timing				1	1				1	1	1
* 3	626410	Limit, 1-pole, 155°F							2				
	626501	Limit, 1-pole, 160°F		2	2		3			3		3	3
	626578	Limit, 1-pole, 180°F				3					3		
	626502*	Limit, 1-pole, 210°F - 90K Btu Pkg. A/C's					3						3
		Limit, 1-pole, 210°F - 90K Btu Pkg. Heat Pump					3						3
Limit, 1-pole, 210°F - 120K Btu Pkg. Heat Pump						3						3	
Not Shown	632225	Circuit Breaker, 3-pole, 60 Amp			1	2	2						
	621667	Contactors, 3-pole, 40 Amp Res.		1					1	1			
	621888	Contactors, 3-pole, 50 Amp Res.			1	2	2				1	1	1

* Factory installed 160°F limits must be replaced with 210°F limits on some unit models.

See Table 1 & Page 6 Application Note

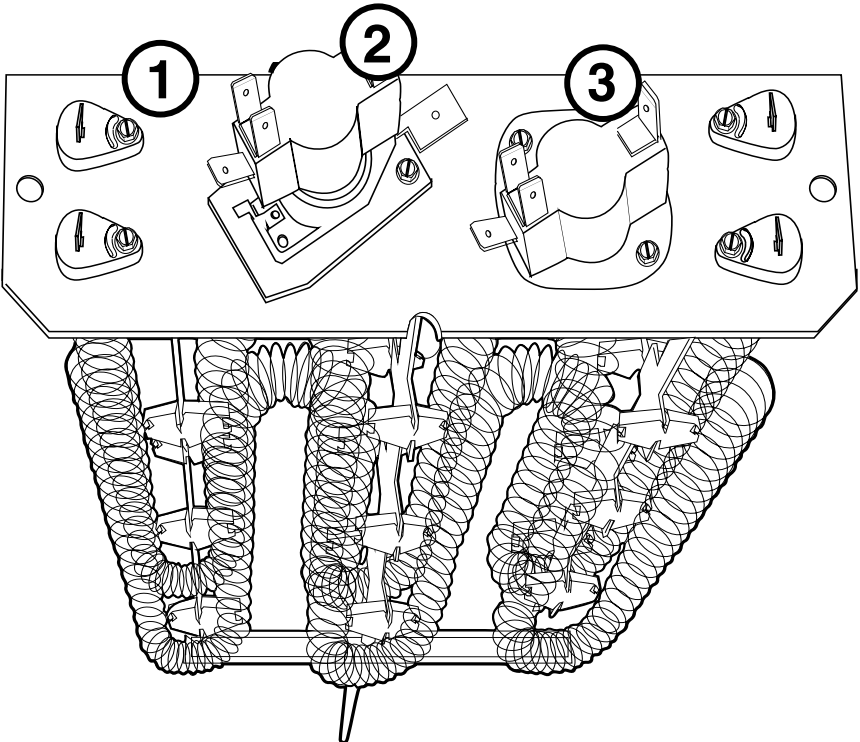

Excerpts from NEC 2005 handbook - based on NFPA 70

Partial Table 310.16 Allowable Ampacities of Insulated Conductors (0-2000 Volts)

- Not more than 3 current carrying conductors in cable or raceway
- Based on Ambient Temp of 30° C

Copper Wire Only

Size	Temperature Rating of Conductor			Size
AWG or kcmil	60° C	75° C	90° C	AWG or kcmil
14	20	20	25	14
12	25	25	30	12
10	30	35	40	10
8	40	50	55	8
6	55	65	75	6
4	70	85	95	4
3	85	100	110	3
2	95	115	130	2
1	110	130	150	1
1/0	125	150	170	1/0
2/0	145	175	195	2/0
3/0	165	200	225	3/0

How to Estimate Unit Supply Wire Requirements:

- 1) Determine Nominal Input Voltage
- 2) Estimate Length of Wire from Breaker to Unit Disconnect
- 3) Find Unit MCA for desired configuration
- 4) Using the minimum wire size based on the unit MCA, calculate the % Voltage Drop to determine the initial wire gauge
The %VD should be 3% or less at the unit
- 5) Verify Unit Voltage is within the Appliances min/max limits
- 6) Verify that the Wire ampacity (corrected for temperature & the # of conductors) is above the Appliances MCA
- 7) Based on final wire gauge selection, determine conduit size. Refer to NEC for details and allowable fill rate

Amb. Temperature Correction Factors

Amb. Temp (°C)	Temperature Rating of Conductor			Amb. Temp (°F)
	60° C	75° C	90° C	
21-25	1.08	1.05	1.04	70-77
26-30	1.00	1.00	1.00	78-86
31-35	0.91	0.94	0.96	87-95
36-40	0.82	0.88	0.91	96-104
41-45	0.71	0.82	0.87	105-113
46-50	0.58	0.75	0.82	114-122
51-55	0.41	0.67	0.76	123-131

- 8) Based on Appliance MOP and final wire selection, make selection of Appliance branch circuit protection

Partial Table 310.15(B)(2)(a) Adjustment factors for more than three current-carrying conductors in a raceway or cable

# of Current-Carrying Conductors	Amount to adjust values in Table 310.16 after correction for Ambient Temperature (if necessary)
4 to 6	80%
7 to 9	70%

Partial Table 9 Effective Impedance for 600V Cables, 3Ø, 60 Hz, 75° C - 3 single current-carrying conductors in conduit

Uncoated Copper Wire Only

AWG or kcmil	Effective Impedance (Z) at 0.85 PF Ω to Neutral / 1000 ft		
	PVC Conduit	Aluminum Conduit	Steel Conduit
14	2.7	2.7	2.7
12	1.7	1.7	1.7
10	1.1	1.1	1.1
8	0.69	0.69	0.70
6	0.44	0.45	0.45
4	0.29	0.29	0.30
3	0.23	0.24	0.24
2	0.19	0.19	0.20
1	0.16	0.16	0.16
1/0	0.13	0.13	0.13
2/0	0.11	0.11	0.11
3/0	0.088	0.092	0.094

$$VoltageDrop_{Line-to-Neutral} = Table9Value \times \frac{CircuitLength}{1000ft} \times UnitMCA$$

$$VoltageDrop_{Line-to-Line} = VoltageDrop_{Line-to-Neutral} \times \sqrt{3}$$

$$\%VoltageDrop = \frac{VoltageDrop_{Line-to-Line}}{NomLineVoltage} \times 100$$

The above tables and recommended procedures are provided for reference only, for complete details refer to the current version of the National Electric Code, the applicable local codes & ordinances, or consult a qualified professional.



Figure 9. Circuit Breaker Mounting Plate Location



Figure 10. Single Contactor Mounting

INSTALLER: PLEASE LEAVE THESE INSTALLATION INSTRUCTIONS WITH THE HOMEOWNER



NORDYNE
COMPLETE COMFORT. GENUINE VALUE.



Specifications & illustrations subject to change without notice or incurring obligations. (01/14)

708740D (Replaces 708740C)