

USER'S MANUAL/INSTALLATION INSTRUCTIONS

P6 Series

Single Package Convertible Air Conditioner

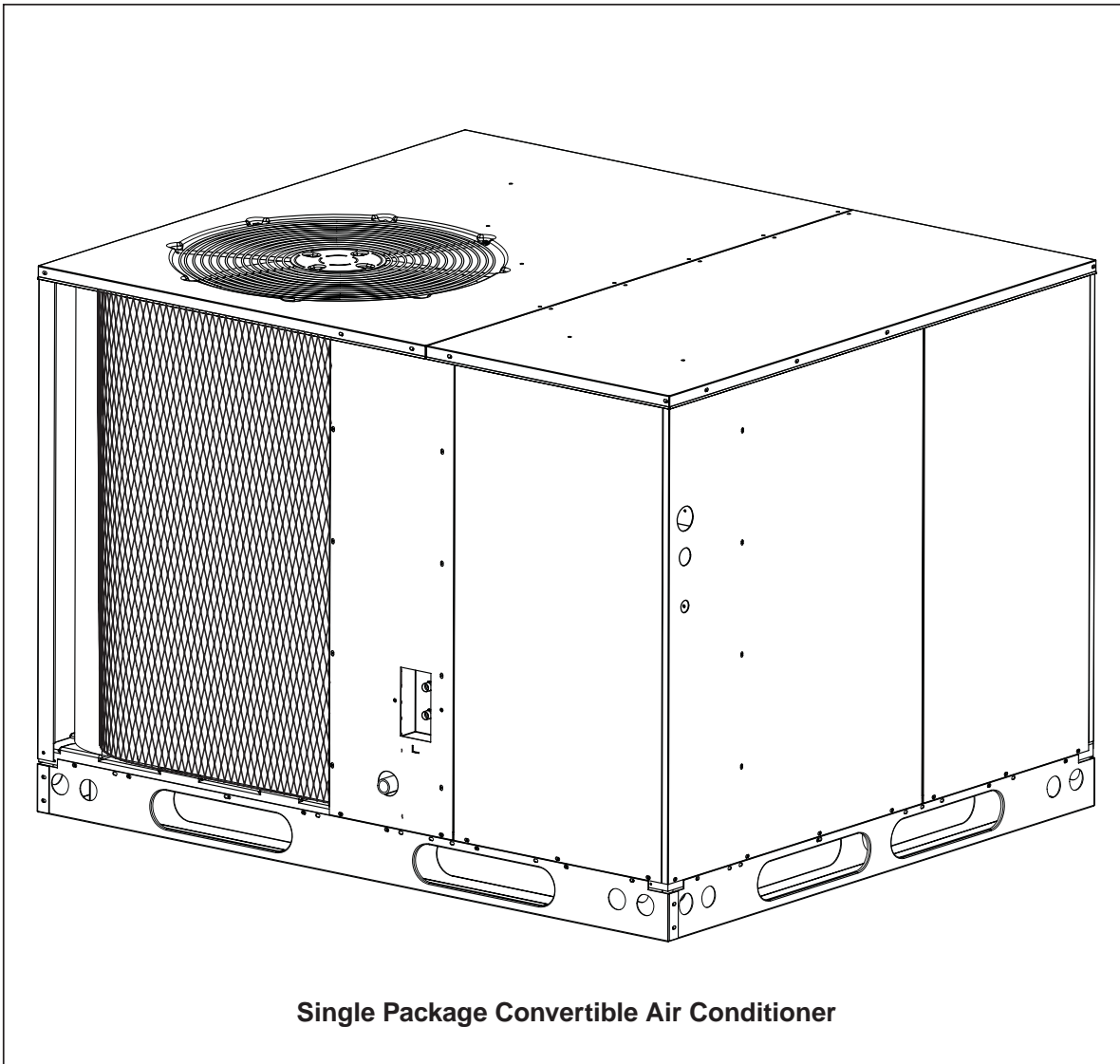

IMPORTANT

These instructions are primarily intended to assist qualified individuals experienced in the proper installation of heating and/or air conditioning appliances. Some local codes require licensed installation/service personnel for this type equipment. All installations must be in accordance with these instructions and with all applicable national and local codes and standards.

Read these instructions thoroughly before starting the installation. Follow all precautions and warnings contained within these instructions and on the unit.

TABLE OF CONTENTS

OWNER INFORMATION	4
OPERATING INSTRUCTIONS	4
GENERAL SPECIFICATIONS	5
SAFETY CONSIDERATIONS	5
Literature, Labels, and Tags.....	5
Pressures Within The System.....	5
INSTALLATION REQUIREMENTS	5
Equipment Check	5
Requirements and Codes.....	5
Unit Dimensions	6
Unit Location.....	7
Air Filter Requirements.....	7
Internal Air Filter Assembly Removal.....	8
Condensate Drain.....	8
UNIT INSTALLATION	8
Ground Level	8
Rigging and Hoisting	8
Rooftop	9
AIR SUPPLY	9
Unconditioned Spaces.....	10
Acoustical Ductwork	10
Horizontal to Down Flow Conversion.....	10
Clearance	10
ELECTRICAL WIRING	10
General.....	10
Line Voltage	10
Blower Speed	11
Room Thermostat.....	11-13
WIRING DIAGRAM	12
SYSTEM CHECK	13
Pre-Start Check List	13
START-UP PROCEDURE	13
Air Circulation	13
System Cooling	13
System Heating	13
UNIT MAINTENANCE	13
Refrigerant Charging	13
Routine Maintenance.....	14
Installation / Removal of Air Filters	14
Package A/C Blower Curves	15
Refrigerant Charging Charts	15-16
Wiring Diagrams	17-18

OWNER INFORMATION

OPERATING INSTRUCTIONS

To Operate Your Air Conditioner for Cooling —

1. Set the thermostat system switch to COOL or AUTO and the thermostat fan switch to AUTO. (See Figure 1)
2. Set the thermostat temperature to the desired temperature level using the temperature selector. Please refer to the separate thermostat user's manual for complete instructions regarding thermostat programming. The outdoor unit and indoor blower will both cycle on and off to maintain the indoor temperature at the desired cooling level.

To Operate Your Unit for Heating — (If optional heat accessory is installed.)

1. Set the thermostat system switch to HEAT or AUTO and the thermostat fan switch to AUTO. (See Figure 1)

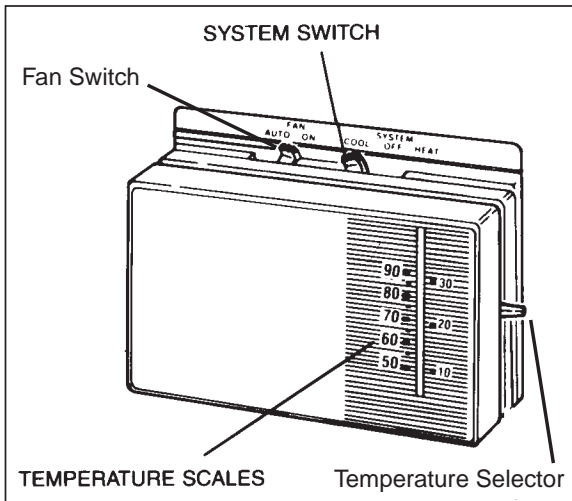

Figure 1. Typical Thermostat

2. Set the thermostat temperature to the desired temperature level using the temperature selector. Please refer to the separate user's manual for complete thermostat programming instructions. The furnace and indoor blower will cycle on and off to maintain the indoor temperature at the desired heating level.

To Shut Off Your Air Conditioner —

Set the thermostat system switch to OFF and the thermostat fan switch to AUTO. (See Figure 1)

The system will not operate, regardless of the thermostat temperature setting.

To Operate the Indoor Blower Continuously—

Set the thermostat fan switch to ON (See Figure 1)

The indoor blower will start immediately, and will run continually until the fan switch is reset to AUTO.

The continuous indoor blower operation can be obtained with the thermostat system switch set in any position, including OFF. The continuous indoor blower operation is typically used to circulate the indoor air to equalize a temperature unbalance due to a sun load, cooking, or fireplace operation.

BEFORE YOU CALL A SERVICEMAN

Let your serviceman check your system at the start of each air conditioning season. He will make sure it's working right, clean or change filters and make any needed adjustments.

Otherwise, follow these simple rules:

1. Never run your system without filter. If you do, the cooling coils will get dirty and may become clogged.
2. Set your thermostat at the comfort level you wish – and then leave it alone. Let it control the operation of the air conditioning system. If you get chilly, turn it up a degree at a time until comfort is restored.
3. It takes longer for an air conditioner to cool your dwelling than it does for your furnace to heat it. So . . . don't turn the unit on and expect a dramatic drop in temperature, at least not right away. If your home is hot and humid, the temperature will drop slowly.
4. Check your filters regularly, to ensure there is not extensive dirt build-up. Replace or clean filter as needed.
5. Keep your condenser coil clean. You can hose it down when it gets dirty.

If your air conditioner isn't working:

1. Make sure the fuses are not blown or that your circuit breakers are on.
2. See that your thermostat is set at the desired temperature and that your system's switch is on "Cool".

3. For free air flow, make sure your return register is not covered and that the filter is clean.
4. Check the condenser coil and make sure it is clean and not clogged with grass or leaves.

If your air conditioner still isn't working, call your nearest contractor.

SPECIFICATIONS

Packaged Air Conditioners are designed for outdoor rooftop or ground level slab installations. The units are shipped ready for horizontal duct connections and are easily converted for downflow applications.

All models are shipped from the factory with the following:

1. Zero clearance to combustibles.
2. Multi-speed direct-drive or fixed torque blower.
3. High Pressure Switch.
4. Blower Speed Relay.
5. Horizontal or Downflow duct connections.

The unit dimensions are shown in **Figure 2**.

Optional field-installed electric heater kits are available in 5 kw through 20 kw heating capacities. A separate installation instruction document for the electric heaters and their application is shipped with the heater kits. A single stage cooling 24VAC thermostat should be used with these units. If electric heat will be installed, a single-stage cooling, single stage heating thermostat will be required.



CAUTION:

This unit uses refrigerant R-410A. DO NOT under any circumstances use any other refrigerant besides R-410A in this unit. Use of another refrigerant will damage this unit.

SAFETY CONSIDERATIONS

It is the responsibility of the installer to ensure that the installation is made in accordance with all applicable local and national codes.



WARNING:

Improper installation, service, adjustment, or maintenance may cause explosion, fire, electrical shock or other hazardous conditions which may result in personal injury or property damage. Unless otherwise noted in these instructions, only factory authorized kits or accessories may be used with this product. Noncompliance may void the unit's warranty.

Labels, Tags — When working with this equipment, follow all precautions in the literature, on tags, and on labels provided with the unit and/or approved field installed kits. The type of hazard and severity are described on each label or tag.

Pressures Within The System — This equipment contains R410-a refrigerant under high pressure. Installation or servicing should only be performed by qualified trained personnel thoroughly familiar with this type equipment.

INSTALLATION REQUIREMENTS

Equipment Check — Before beginning the installation, verify that the unit model is correct for the job. The unit model number is printed on the data label. All units have been securely packaged at the point of shipment. After unpacking the unit, carefully inspect it for apparent and concealed damage. Claims for damage should be filed with the carrier by the consignee.

Requirements and Codes — The installer must comply with all local codes and regulations which govern this type equipment. Local codes and regulations take precedence over any recommendations contained in these instructions. All electrical wiring must be made in accordance with local codes and regulations and with the National Electric Code (ANSI/NFPA 70) or in Canada the Canadian Electric Code Part 1 CSA C.22.1. Air Ducts must be installed in accordance with the standards of the National Fire Protection Association "Standards for Installation of Air Conditioning and Ventilation Systems" (NFPA 90A), "Standard for Installation of Residence Type Warm Air Heating and Air

Model No. P6SD	Unit Weight	Center of Gravity		Height (in inches) C	
		A	B	with base rails	without base rails
				C	
X36	405	29.5	26.0	37.7	35.3
X48	415	29.5	26.5	37.7	35.3
X60	480	30.0	27.5	41.7	39.3

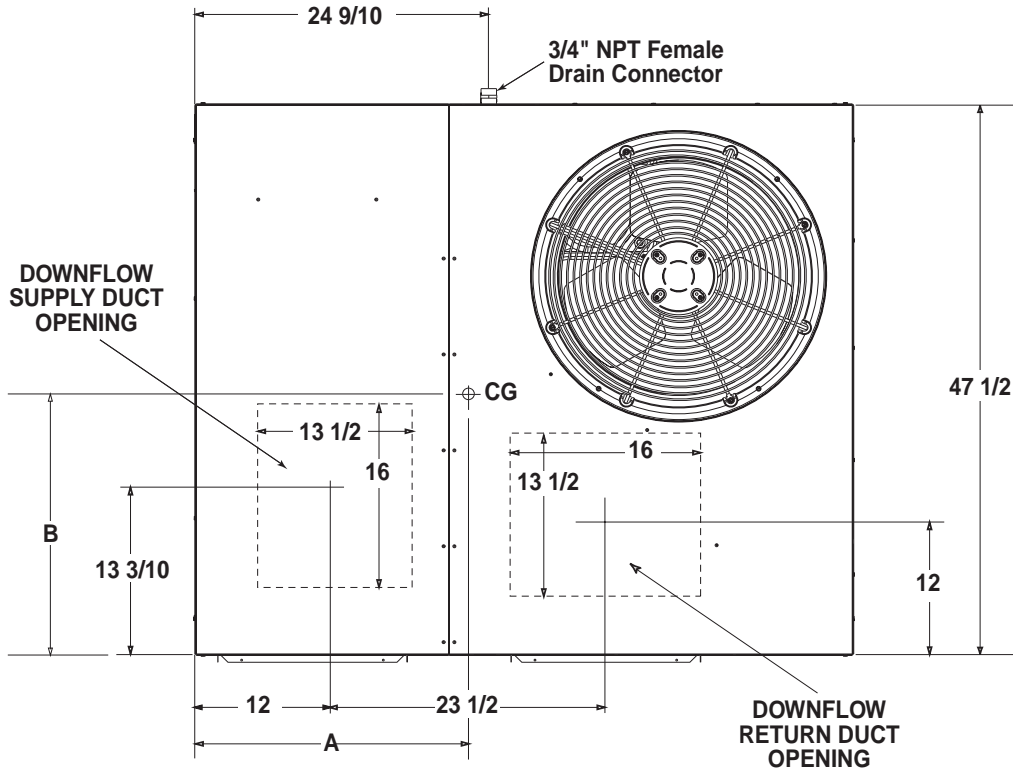

Top View

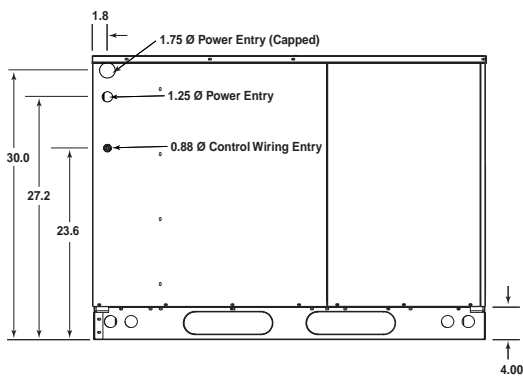

Side View

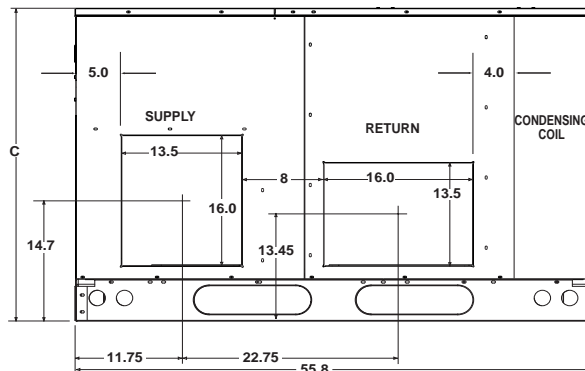

Back View

Figure 2. Dimensions

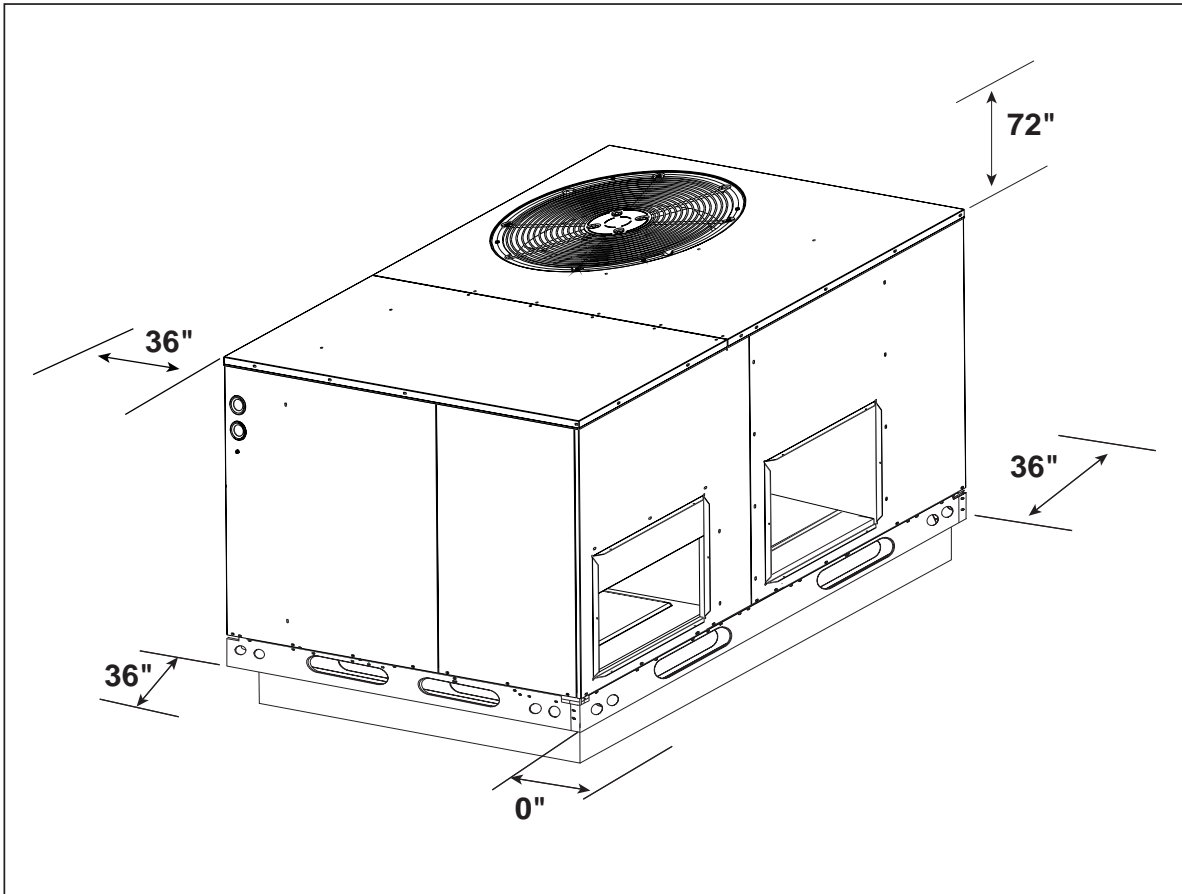

Figure 3. Minimum Clearances

Conditioning Systems” (NFPA 90B), these instructions and all applicable local codes.

NFPA publications are available by writing:

National Fire Protection Association
 Batterymarch Park
 Quincy, Maine 02269

Unit Location — This air conditioner is designed only for outdoor installations. Choosing the location of the unit should be based on minimizing the length of the supply and return ducts. Consideration should also be given to availability of electric power, service access, noise, and shade. Sufficient clearance for unobstructed airflow through the outdoor coil must be maintained in order to achieve

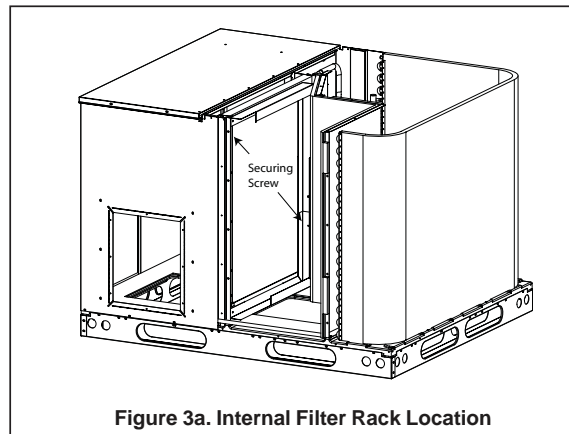

Figure 3a. Internal Filter Rack Location

rated performance See **Figure 3** for minimum clearances to obstructions.

Air Filter Requirements — Three phase units “Only” are supplied from the factory with an internal filter rack assembly. Air filters are not supplied; a suitable air filter must be installed in the unit or in the return air system for all units. See Table 1 for internal filter size requirements. When utilizing an Economizer or Fresh Air Equipment, the factory installed filter rack assembly must be removed prior to installation. Refer to Table 1 for recommended filter sizes when the factory installed filter system is not used. Air filter pressure drop must not exceed

Unit Size	Internal Filter Size
R6GD-X36	(2) 14" x 25" x 1" or (2) 14" x 25" x 2"
P6SD-X36	
P6SD-X48	
Q6SD-X36	
P6SD-X60 Q6SD-X48/X60, R6GD-X48/X60	(2) 16" x 25" x 1" or (2) 16" x 25" x 2"

Table 1. Internal Filter Size Requirements.

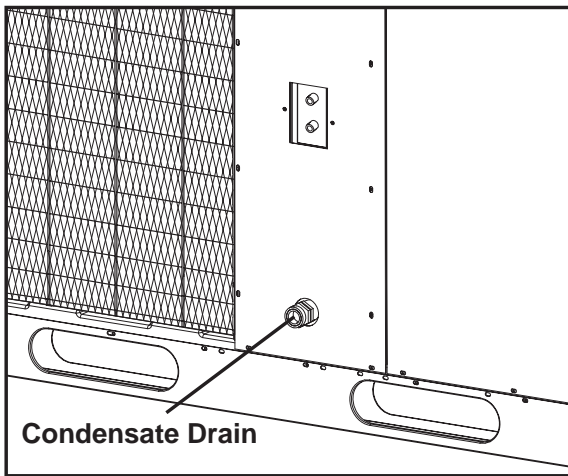

Figure 4. Condensate Drain

0.08 inches WC. Air filter(s) must be installed in the return air ductwork ahead of the evaporator coil of this unit. All return air to this unit must pass through the filter(s) before entering this unit. (See Routine Maintenance for Installation/Removal of air filters).

Removal of Internal Filter Rack — First remove the Return Air Panel from the unit. Remove the height adjustment screw from the inside of the rack, and the (1) screw securing the assembly to the coil located on the left leg of the rack. The assembly can easily be collapsed and removed from the unit. See Figure 3a for filter rack securing screw locations.

Condensate Drain — Condensate is removed from the unit through the 3/4" female pipe fitting located on the front side of the unit. (See **Figure 4.**) Install a 2 inch condensate trap in the drain line of the same size and prime with water. When connecting rigid drain line, hold the female fitting with a wrench to prevent twisting. **Do not over-tighten!** Refer to local codes and restrictions for proper condensate disposal requirements.

UNIT INSTALLATION

Ground Level — When installing the unit at ground level, provide a concrete mounting pad separate from the building foundation. The pad must be level to insure proper condensate disposal and strong enough to support the unit's weight. Refer to **Figure 2** . Make sure the slab is a minimum of 2" above the grade and in an area that drains well. (**Figure 5**)

! CAUTION:

All panels must be securely in place when rigging and hoisting.

Rigging and Hoisting — The unit should be lifted using slings and spreader bars. The spreader bars are necessary to prevent damaging the top of the unit's cabinet. Make sure that the lifting equipment is adequate for the load. Refer to **Figure 2** for unit weights. Keep the unit in an

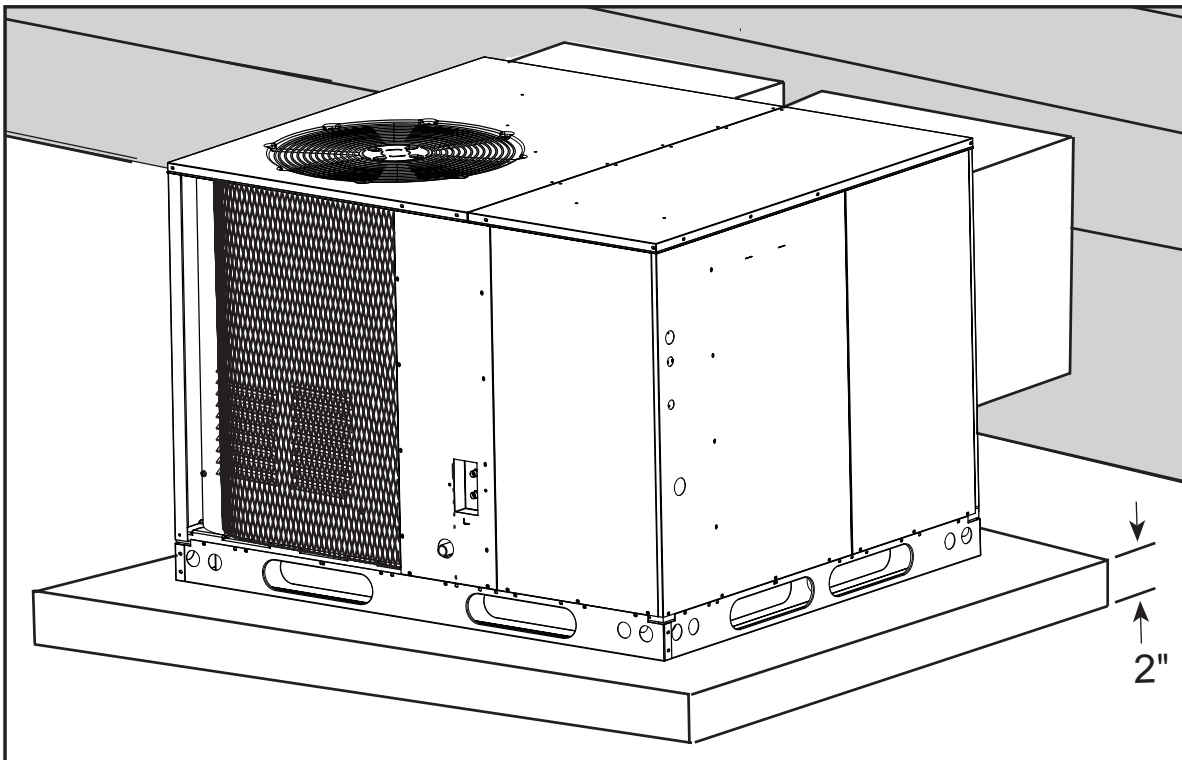

Figure 5. Ground Level Installation

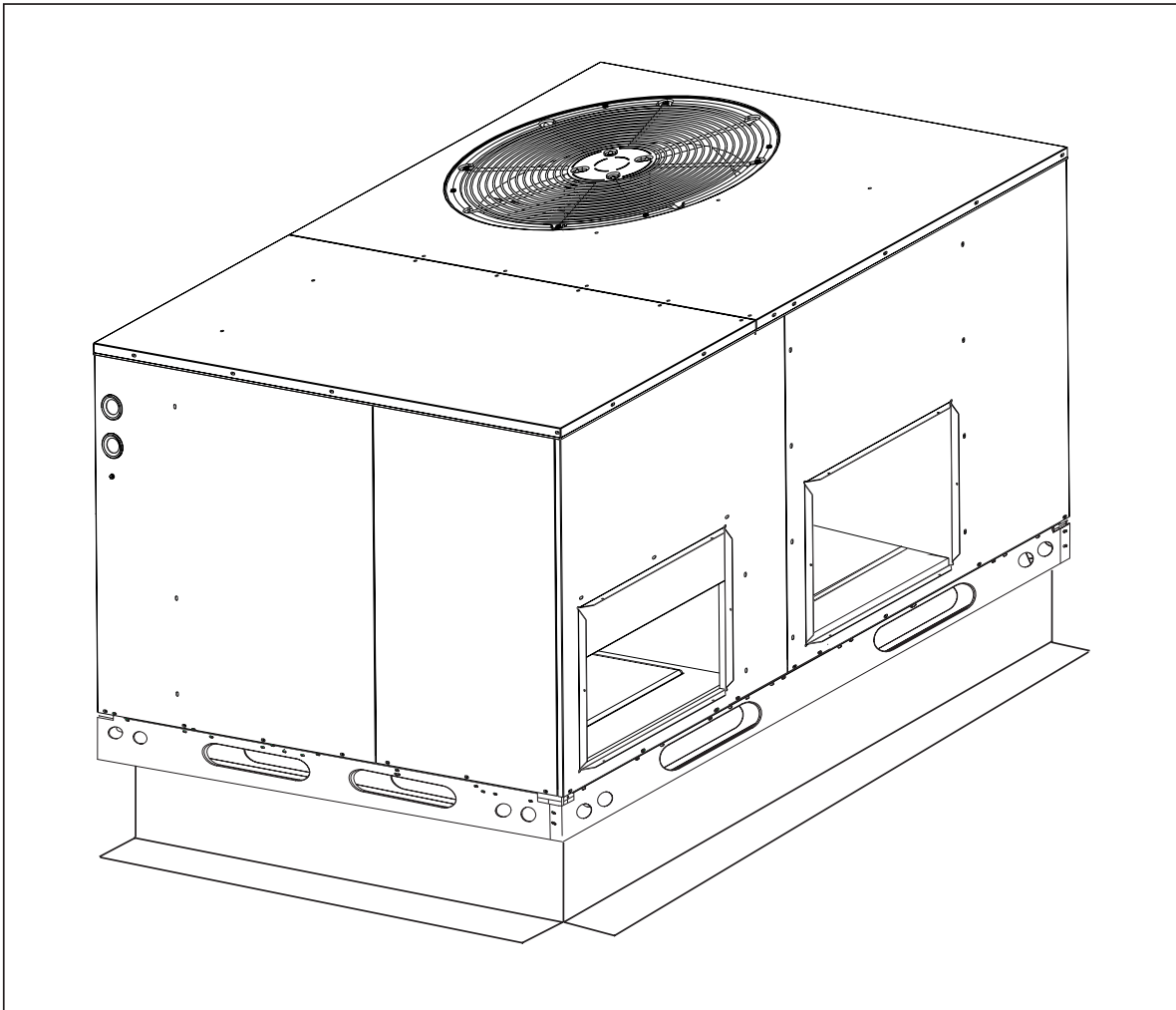

Figure 6. Roof Top Installation

upright position at all times. **For rooftop installations, remove and discard the two supports attached beneath the unit.**

! WARNING:

To avoid the risk of property damage or personal injury; it is the rigger's responsibility to insure that whatever means are used to hoist the unit are safe and adequate.

The rigging must be located outside the unit's center of gravity. Refer to **Figure 2** for center of gravity location.

Rooftop — For rooftop installations use the appropriate accessory roof curb and follow all instructions included with it. Make sure the two supports beneath the unit have been removed. Locate the unit according to local building codes and ordinances. The curb must be level to insure proper condensate drainage. **(See Figure 6)**

The roof must be capable of handling the weight of the unit. **(See Figure 2)** for unit weights. Reinforce the roof if required.

AIR DUCTS

This unit is designed only for use with a supply and return duct. Air ducts should be installed in accordance with the standards of the National Fire Protection Association "Standard for Installation of Air Conditioning Systems" (NFPA 90A), "Standard for Installation of Residence Type Warm Air Heating and Air Conditioning Systems" (NFPA 90B), and all applicable local codes.

Design the duct work according to methods described by the National Warm Air Heating and Air Conditioning Association (ACCA). The ducts must be properly sized not to exceed .2" w.c. pressure drop at 400 scfm per nominal ton of cooling capacity.

Duct work should be attached directly to the unit flanges for horizontal applications. On roof curb installations the ducts must be attached to the curb hangers, not the unit.

Unconditioned Spaces — All duct work passing through unconditioned space must be properly insulated to minimize duct losses and prevent condensation. Use insulation with an outer vapor barrier. Refer to local codes for insulation material requirements.

Acoustical Duct Work — Certain installations may require the use of acoustical lining inside the supply duct work. Acoustical insulation must be in accordance with the current revision of the Sheet Metal and Air Conditioning Contractors National Association (SMACNA) application standard for duct liners. Duct lining must be UL classified batts or blankets with a fire hazard classification of FHC-25/50 or less. Fiber duct work may be used in place of internal duct liners if the fiber duct work is in accordance with the current revision of the SMACNA construction standard on fibrous glass ducts. Fibrous duct work and internal acoustical lining must be NFPA Class 1 air ducts when tested per UL Standard 181 for Class 1 ducts.

Horizontal to Down flow Conversion — The unit is shipped ready for horizontal duct connections. If down flow ducts are required, the unit must be converted following the steps below for both the supply and return ducts.

- 1) Locate the duct cap inside the duct openings and remove the screw holding it in place.
- 2) Lift the cap out of the unit. (The cap can be pushed up from the bottom by reaching through the fork slot).
- 3) Cover the horizontal duct opening with the cap. The insulation will be on the indoor side.
- 4) Fasten the cover with screws and seal to prevent air leakage.

Clearance — This unit is approved for 6 inch clearance.

ELECTRICAL WIRING

General — Electrical power wiring must be made in accordance with all applicable local

codes and ordinances, and with the current revision of the National Electric Code NFPA 70 or in Canada CSA C.22.1 - Canadian Electrical Code Part 1. If any of the original wire as supplied with the unit must be replaced, it must be replaced with material of the same gauge and temperature rating.



WARNING:

To avoid risk of electrical shock, personal injury, or death, disconnect all electrical power to the unit before performing any maintenance or service. The unit may have more than one electrical supply.

Line Voltage — Before proceeding with the electrical connections, make certain that the voltage, frequency, and phase of the supply source are the same as those specified on the unit rating plate. Also verify that the service provided by the utility is sufficient to handle the additional load imposed by this equipment.

See the unit wiring label for proper high and low voltage wiring. Make all electrical connections in accordance with all applicable codes and ordinances.

Use a separate branch electrical circuit for this unit. A means of electrical disconnect must be located within sight of and readily accessibility to the unit. Internally mounted circuit breakers are available as field installed options. These circuit breakers can be used as an electrical disconnect.

The unit is shipped from the factory wired for 240 volt transformer operation. For 208 volt operation, remove the lead from the transformer terminal marked 240V and connect it to the terminal marked 208V. For maximum ampacity and over current protection, see the unit rating plate.

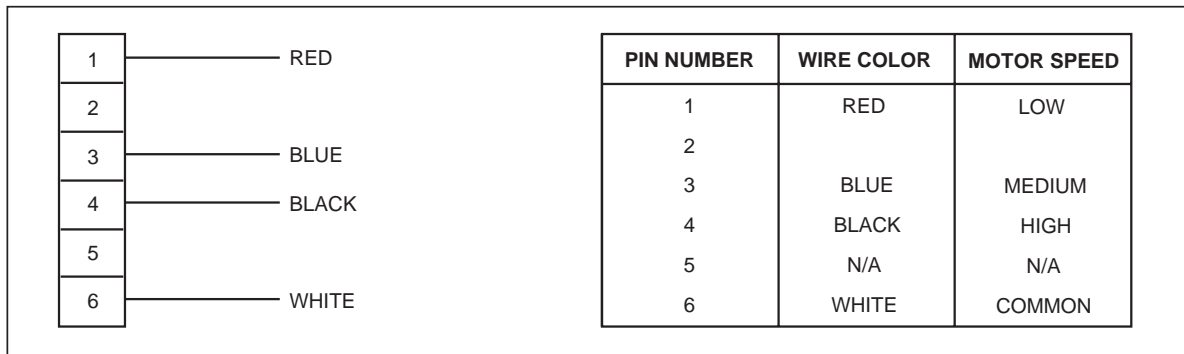

Figure 7. Motor Lead Connector - Standard Motor

Provide power supply (or supplies) for the unit in accordance with the unit wiring diagram, and the unit rating plate. Connect the line-voltage leads to the corresponding terminals on the contactor (or the circuit breaker when the field installed circuit breaker kits are used) inside the control compartment. Use only copper wire for the line voltage power supply to this unit. Use proper code agency listed conduit and a conduit connector for connecting the supply wires to the unit and for obtaining proper grounding. Grounding may also be accomplished by using the grounding lug provided in the control box.

WARNING:

The unit cabinet must have an uninterrupted or unbroken electrical ground to minimize personal injury if an electrical fault should occur. This ground may consist of electrical wire or approved conduit when installed in accordance with existing national or local codes.

Blower Speed — The blower speed is preset at the factory for operation at the same speed for heating and cooling. For optimum system performance and comfort, it may be necessary to change the factory set speed. See table 1 for factory settings. To change the blower speed:

If Standard Motor:

1. Disconnect all electrical power to the unit and remove the service panel.
2. Remove the motor lead from terminal #4 of the blower relay. Cut the wire tie holding the motor lead bundle. The motor leads are color coded as shown in **Figure 7**.
3. If the desired heating blower speed is different than the cooling speed, remove and discard the jumper wire between terminals #6 and #4. on the blower relay. Place the desired heating blower speed lead on terminal #6 and the desired cooling blower speed lead on terminal #4 of the blower relay. Use another wire tie (field supplied) to bundle the remaining motor leads.

If Fixed Torque Motor:

1. Disconnect all electrical power to the unit and remove the blower panel.
2. Locate the orange and red wires terminated to the blower motor. The orange wire controls cooling operation while the red wire controls heating operation.

3. Verify the required speed from the airflow data found in table 1. Place appropriate wire on the appropriate motor speed tap for the required airflow point.

Check all factory wiring per the unit wiring diagram and inspect the factory wiring connections to be sure none loosened during shipping or installation.

CAUTION:

To avoid personal injury or property damage, make certain that the motor leads cannot come into contact with any uninsulated metal components of the unit.

Low Voltage Connections

Room Thermostat — Several options are available for a room thermostat depending on the accessories installed with the unit. Select a thermostat which operates in conjunction with the installed accessories. The thermostat should be mounted about five feet above the ground on an inside wall. The thermostat should be kept away from drafts, slamming doors, lamps, direct sunlight, or in line with the supply air flow.

To install the thermostat:

1. Position the sub base on an inside wall and mark the mounting holes and thermostat cable openings.
2. Cut out the cable opening and route the thermostat cable from the unit's low voltage compartment to the thermostat location. The thermostat cable is supplied by the installer.
3. Connect the cable leads to the sub base or thermostat terminals and to the unit's low voltage pigtails as shown in **Figure 8**. A system wiring diagram is also provided on the inside of the control panel cover.
4. Secure sub base or thermostat to the wall using screws provided with the thermostat.
5. If sub base is used, install the correct thermostat housing to sub base.
6. Refer to thermostat instruction sheet for complete detailed mounting information.

Field Installed Electric Heat — This Packaged Air Conditioner is designed to allow optional electric heat to be field installed as required by the building's particular heating load.

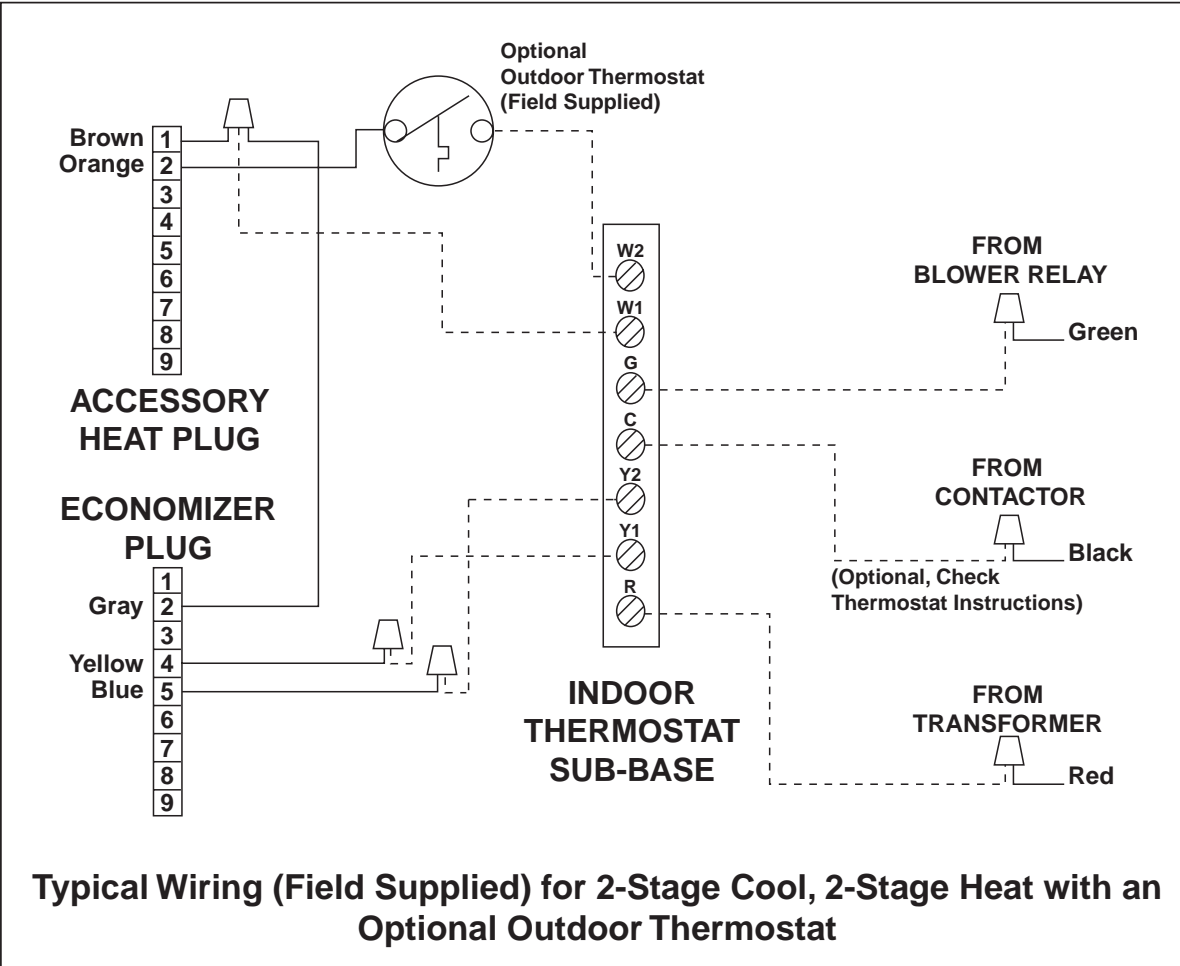
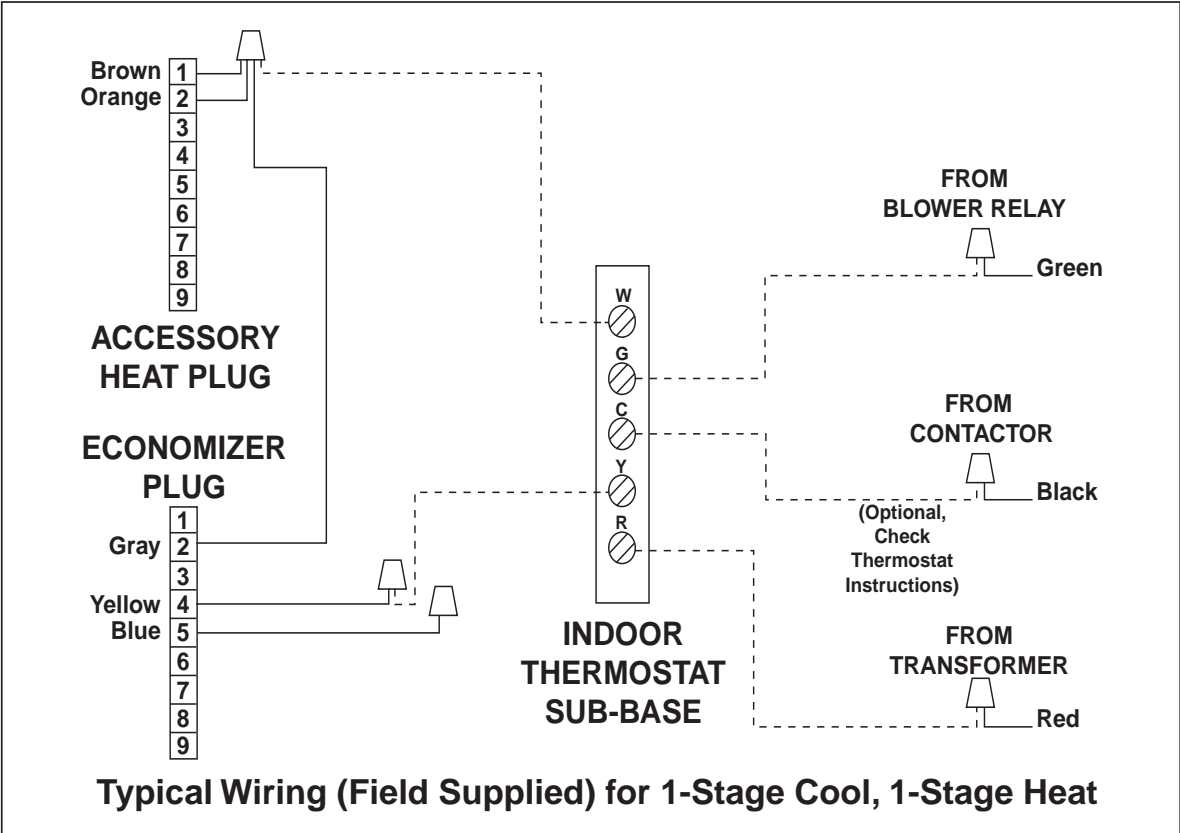

Figure 8. Typical Air Conditioner Thermostat Connections

The options available for each unit are shown in the heater kit installation instructions.

Install the heater kits as directed by the installation instructions that come as part of the heater kit. Follow all cautions and warnings as directed.

START UP AND SYSTEM CHECK

Pre-Start Check List

- Verify that the unit is level to allow proper condensate drainage.
- Verify that there is free airflow to and from the outdoor coil and that all clearance requirements are met.
- Verify that the duct work is sealed to prevent air leakage.
- Verify that the line voltage power leads are securely connected and the unit is properly grounded.
- Verify that the low voltage wires are securely connected to the correct leads on the low voltage terminal strip.
- Verify that all exterior panels are replaced and securely fastened.
- Verify that the outdoor fan turns freely.
- Verify that the power supply branch circuit overcurrent protection is sized properly.
- Verify that the thermostat is wired correctly. The thermostat function switch should be set to "Off" and the thermostat fan switch should be set to "Auto".

Start-Up Procedure

Close all electrical disconnects to energize the system.



WARNING:

If the unit is equipped with a crankcase heater, allow 24 hours prior to continuing the start up procedures to allow for heating of the refrigerant compressor crankcase. Failure to comply may result in damage and could cause premature failure of the system. This warning should be followed at initial start up and any time the power has been removed for 12 hours or longer.

Air Circulation — Leave the thermostat system switch set to "Off" and set the thermostat fan switch to "On". The blower motor should run

continuously. Check for air delivery at the register(s). Ensure that there are no obstructions at the registers or in the duct work. Set thermostat fan switch to "Auto."

System Cooling

1. Set the thermostat system switch to "Cool" and the thermostat fan switch to "Auto". Gradually lower the thermostat temperature switch below room temperature and observe that the blower, compressor, and fan energize. Check that air cooler than room temperature is being discharged at the register. Listen for any unusual noises. Locate the source and correct as needed.
2. After allowing the unit to run for several minutes, set the temperature selector above room temperature.
 - The fan and compressor cycles off with the thermostat.
 - The blower should also stop unless fan switch is set to "ON" position.

System Heating — If the unit has been equipped with optional electric heater kits, set the system thermostat switch to HEAT and set the thermostat fan switch to AUTO. Verify that the compressor and outdoor fan are not energized but that the blower and heaters are. Check for warm air at the supply registers.

UNIT MAINTENANCE



WARNING:

To avoid risk of electrical shock, personal injury, or death, disconnect all electrical power to the unit before performing any maintenance or service. The unit may have more than one electrical supply.

Refrigerant Charging — Packaged air conditioners are fully charged with R-410A refrigerant at the factory. The system refrigerant charge can be checked and adjusted through the service ports provided on the front panel. Use only gauge lines which have a "Schrader" depression device present to actuate the valve. Draw a vacuum on gauge lines to remove air before attaching them to the service ports on the unit. Refrigerant charging must be done by qualified personnel familiar with safe and environmentally responsible refrigerant handling procedures.

**WARNING:**

Single Packaged Air Conditioners are shipped fully charged with R-410A refrigerant and ready for installation. When a system is installed according to these instructions, no refrigerant charging is required. If repairs make it necessary for evacuation and charging, it should only be done by qualified, trained personnel thoroughly familiar with this equipment. Some local codes require licensed installation/service personnel to service this type of equipment. Under no circumstances should the owner attempt to install and/or service this equipment. Failure to comply with this warning could result in property damage, personal injury, or death.

**CAUTION:**

Use care when removing parts from this unit. Personal injury can result from sharp metal edges present in all equipment of sheet metal construction.

Routine Maintenance — Proper maintenance is important to achieve optimum performance from the air conditioner. The ability to properly perform maintenance on this equipment requires certain mechanical skills and tools. If you do not possess these skills, contact your dealer for maintenance. Consult your local dealer about the availability of maintenance contracts. At a minimum, routine maintenance should include the following:

1. Inspect and clean or replace air filters at the beginning of each heating and cooling season, or more frequently if required.
2. Inspect the condensate drain and outdoor coil at the beginning of each cooling season. Remove any debris. Clean the outdoor coil and louvers as necessary using a mild detergent and water. Rinse thoroughly with water.
3. Inspect the electrical connections for tightness at the beginning of each heating and cooling season. Service as necessary.

INSTALLING FILTERS IN THE FACTORY INSTALLED FILTER RACK

1. Remove access panel screws from return air panel. (You may want to loosen the unit's Top Panel screws that are located near the top edge of the access panel. The access panel was designed to be captured underneath the Top Panel.)
2. To install media, slide filter between guide channels of filter rack. The first filter will easily drop into place. (Check to insure that the bottom of filter is within the channels of the rack.) Insert the second media in the same manner as the first. (Again, check to insure that the media is captured by the channels of the filter rack.)
3. Replace access cover by sliding the top edge of panel under the lip of the unit's Top Panel. Secure Access Panel by replacing the screws.

REMOVAL OF FILTERS FROM FACTORY INSTALLED FILTER RACK

1. Remove access panel screws from return air panel. (You may want to loosen the unit's Top Panel screws that are located near the top edge of the access panel. The access panel was designed to be captured underneath the Top Panel.)
2. To remove upper media, gently pull filter through the Access Panel opening.
3. To remove lower media, lift media to top of Filter Rack and remove in the same manner as described in step two.
4. Replace old filter with new media per the Insertion Instruction detailed above.

**CAUTION:**

The unit should never be operated without a filter in the return air system. Replace disposable filters with the same type and size.

P6 Series Blower Curves

Model Number		External Static Pressure Drop - inches water column							
P6SD-		0.1	0.2	0.3	0.4	0.5	0.6	0.7	0.8
X36	High	1610	1562	1504	1442	1365	1295	1214	1109
	Medium	1367	1320	1271	1205	1138	1065	968	845
	* Low	1153	1102	1043	990	912	831	731	618
X48	High	2361	2278	2218	2141	2066	1976	1870	1758
	Medium	2026	1982	1935	1889	1822	1744	1660	1554
	* Low	1584	1568	1532	1489	1445	1387	1322	1236
X60	* Tap T1	1515	1450	1380	1350	1280	1250	1200	1160
	* Tap T2	1580	1520	1460	1400	1300	1280	1260	1230
	* Tap T3	1740	1690	1650	1600	1360	1500	1460	1390
	* Tap T4	1960	1910	1840	1820	1540	1740	1700	1600
	* Tap T5	2090	2050	2010	1975	1780	1900	1850	1790

* Denotes factory set cooling speed

** Denotes factory set electric heating speed

NOTE: Airflow performance is with a dry coil

Table 1. Packaged Air Conditioner Blower Curves

Cooling Charging Charts

P6SD-X36 Charging Chart - Cooling

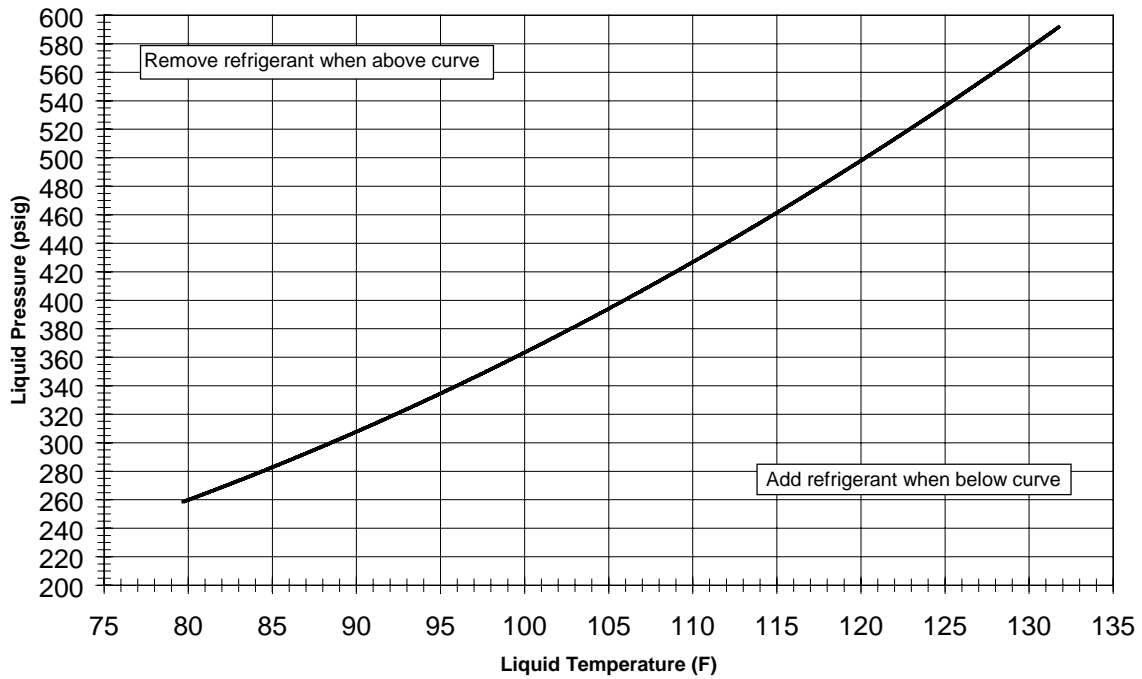
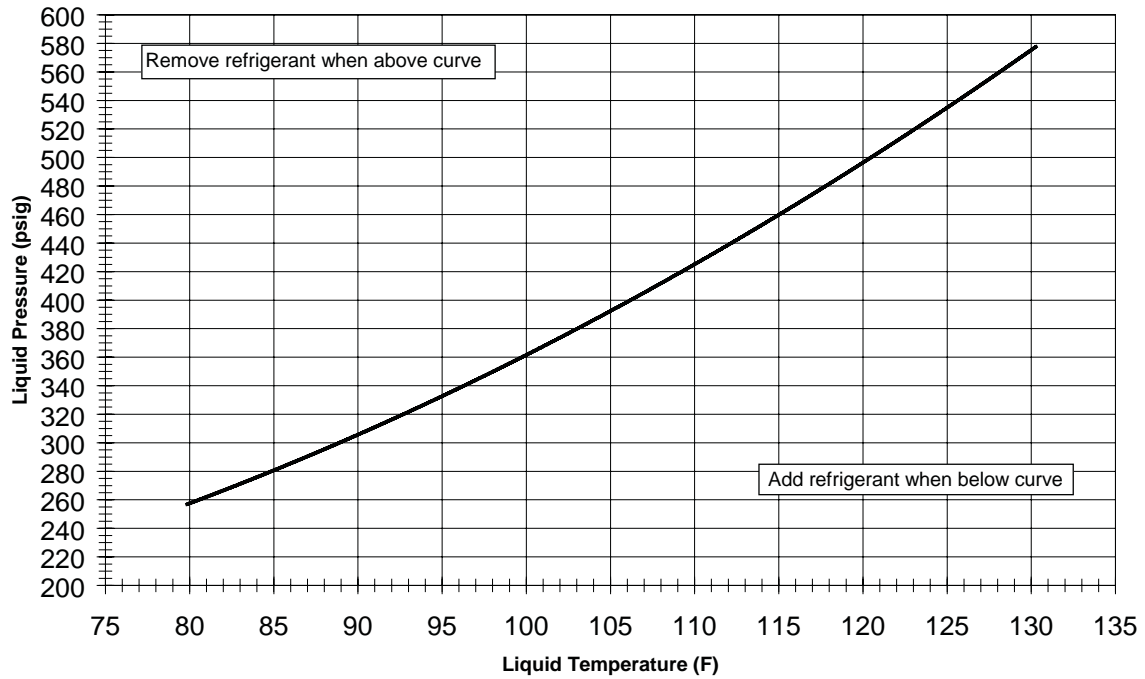

Figure 9: 13 SEER Cooling Charging Charts

Cooling Charging Charts (cont.)

P6SD-X48 Charging Chart - Cooling



P6SD-X60 Charging Chart - Cooling

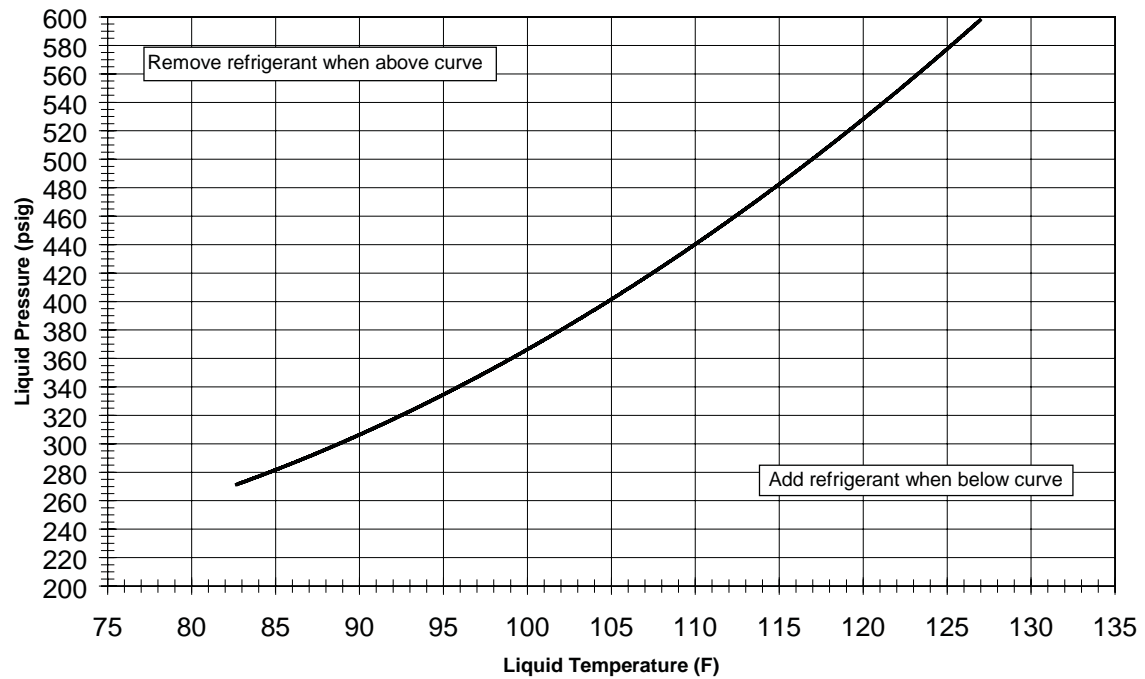

Figure 9. 13 SEER Cooling Charging Charts

Convertible Packaged Air Conditioner

- NOTES:**
1. Disconnect all power before servicing.
 2. For supply connections use copper conductors only.
 3. Not suitable on systems that exceed 150 V to ground.
 4. If any of the original wire as supplied with the furnace must be replaced, it must be replaced with wiring material having a temperature rating of at least 105°C.
 5. For supply wire ampacities and overcurrent protection, see unit rating plate.

208/230 Volt

Three Phase 60Hz

1. Couper le courant avant de faire le r  tretien.
2. Employez uniquement des conducteurs en cuivre.
3. Ne convient pas aux installations de plus de 150 V la terre.

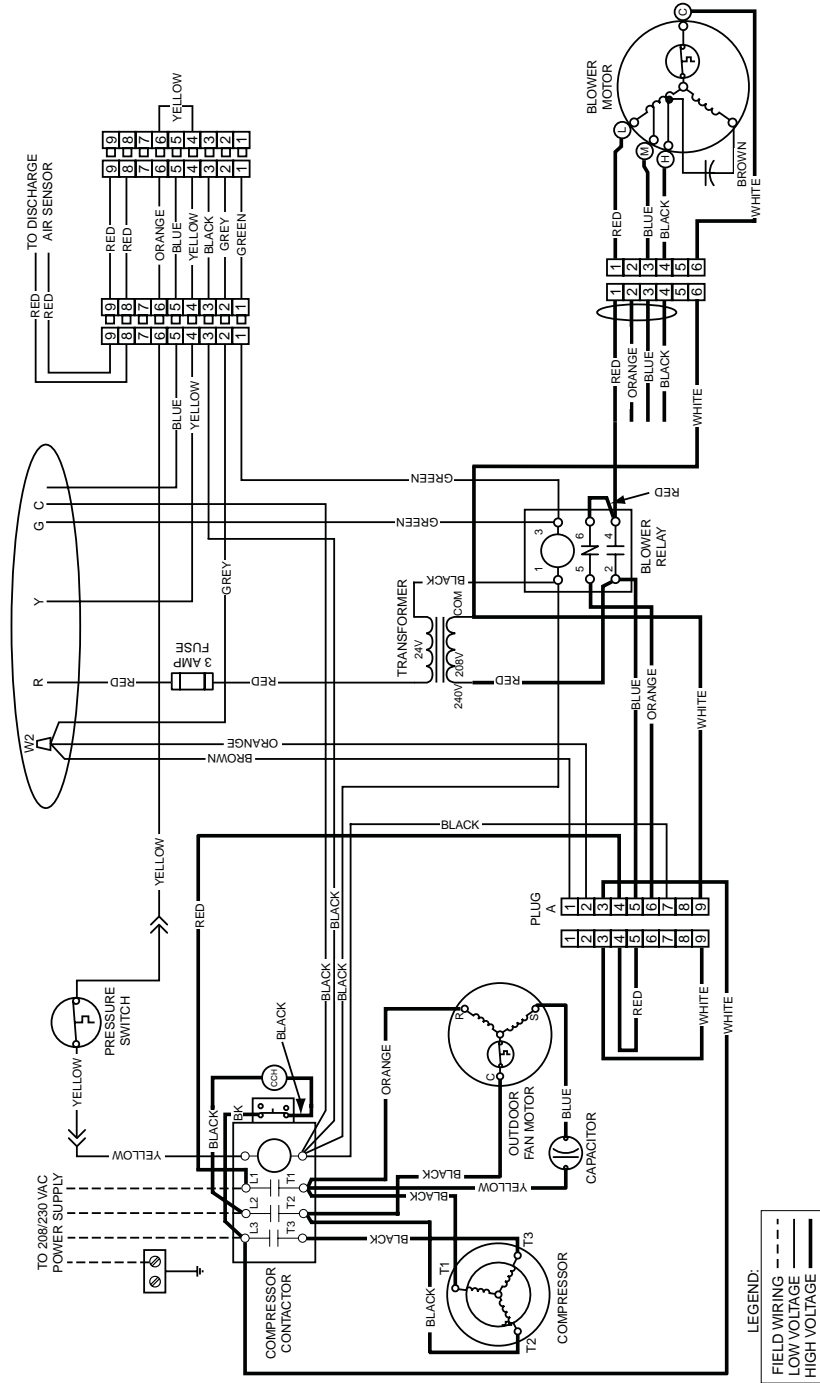

7107630

Figure 10. Wiring Diagram-Standard Motor

Convertible Packaged Heat Pump

208/230 Volt

Three Phase 60Hz

NOTES:

1. Disconnect all power before servicing.
2. For supply connections use copper conductors only.
3. Not suitable on systems that exceed 150V to ground.
4. If any of the original wire as supplied with the furnace must be replaced, it must be replaced with wiring material having a temperature rating of at least 105°C.
5. For supply wire ampacities overcurrent protection, see unit rating plate.

1. Couper le courant avant de faire leretien.
2. Employez uniquement des conducteurs en cuivre.
3. Ne convient pas aux installations de plus de 150 V a la terre.

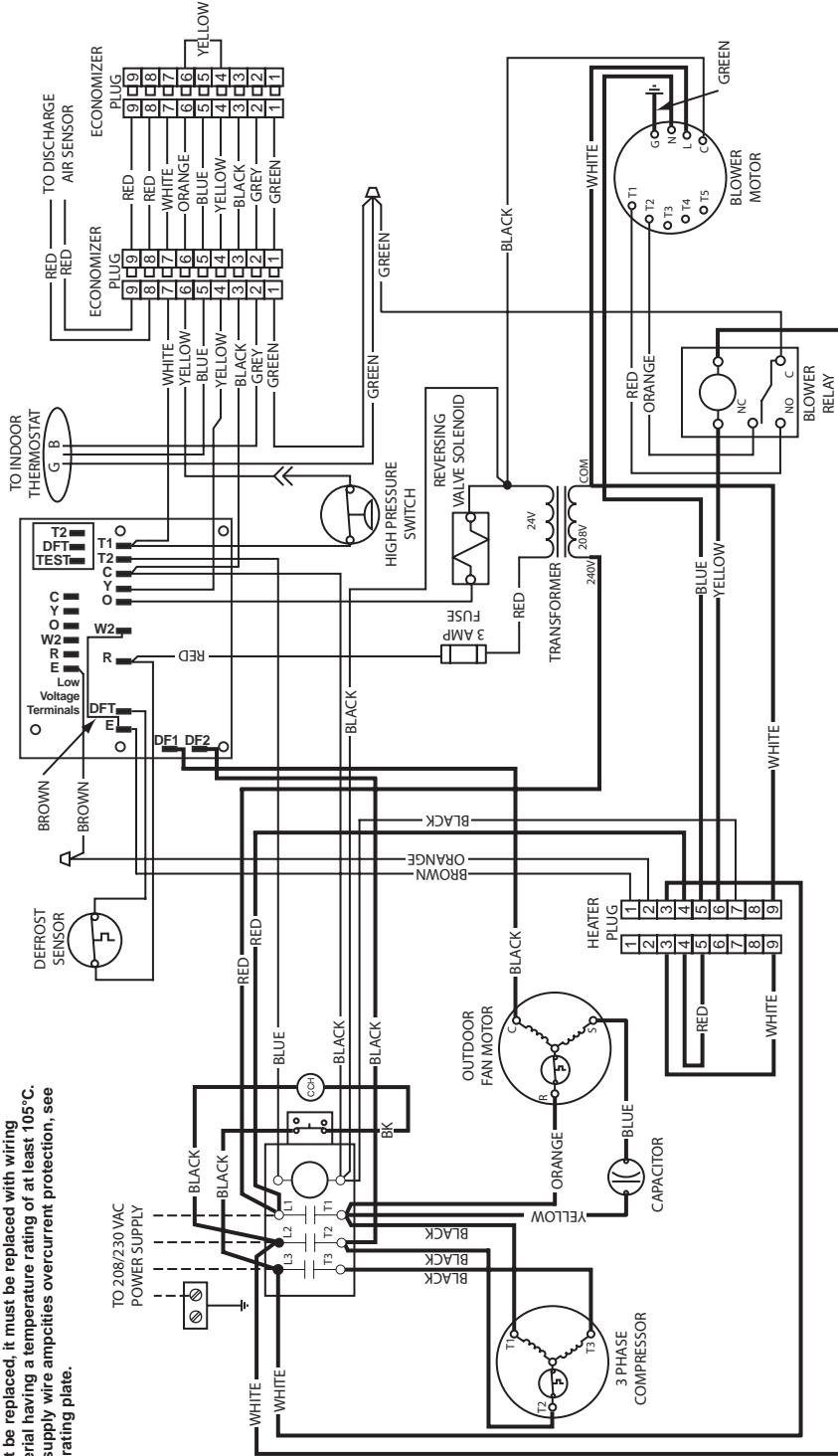

DEFROST BOARD OPERATION:

- ① CLOSES DURING DEFROST. RATING: 1 A MAXIMUM
- ② OPENS DURING DEFROST. RATING: 2 HP AT 230 VAC MAXIMUM
- ③ CLOSURE WHEN "Y" IS ENERGIZED, OPEN WHEN "Y" IS DEENERGIZED.
- ④ PROVIDES "OFF" DELAY TIME OF 5 MIN WHEN "Y" IS DEENERGIZED.
- ⑤ WITH DFT CLOSED AND "Y" ENERGIZED, COMPRESSOR RUN TIME IS ACCUMULATED.
- ⑥ OPENING OF DFT DURING DEFROST OR INTERVAL PERIOD RESETS THE INTERVAL TO 0.



NOTE: See Installation Instructions for wiring, application, and information concerning accessory Heat Kits and other options.

7107640

Figure 11. Wiring Diagram-Fixed Torque Motor

**INSTALLER
PLEASE LEAVE THESE
INSTALLATION INSTRUCTIONS
WITH THE HOMEOWNER.**

