

INSTALLATION INSTRUCTIONS

Single Package Gas Heating / Electric Cooling Rooftop Units



R6GN-150 Series Shown

⚠ WARNING:

FIRE OR EXPLOSION HAZARD

- Failure to follow safety warnings exactly could result in serious injury or property damage.
- Installation and service must be performed by a qualified installer, service agency or the gas supplier.
- Do not store or use gasoline or other flammable vapors and liquids in the vicinity of this or any other appliance.

WHAT TO DO IF YOU SMELL GAS

- Do not try to light any appliance.
- Do not touch any electrical switch; do not use any phone in your building.
- Leave the building immediately.
- Immediately call your gas supplier from a neighbor's phone. Follow the gas supplier's instructions.
- If you cannot reach your gas supplier, call the fire department.

⚠ AVERTISSEMENT

RISQUE D'INCENDIE OU D'EXPLOSION

- Le non-respect des avertissements de sécurité pourrait entraîner des blessures graves, la mort ou des dommages matériels.
- L'installation et l'entretien doivent être effectués par un installateur qualifié, un organisme de service ou le fournisseur de gazstaller, service agency or the gas supplier.
- Ne pas entreposer ni utiliser de l'essence ni d'autres vapeurs ou liquides inflammables dans le voisinage de cet appareil, ni de tout autre appareil.

QUE FAIRE S'IL Y A UNE ODEUR DE GAZ

- Ne pas tenter d'allumer aucun appareil.
- Ne toucher à aucun interrupteur électrique; n'utiliser aucun téléphone dans le bâtiment.
- Évacuer l'immeuble immédiatement.
- Appeler immédiatement le fournisseur de gaz en employant le téléphone d'un voisin. Respecter à la lettre les instructions du fournisseur de gaz.
- Si personne ne répond, appeler le service des incendies.

TABLE OF CONTENTS

IMPORTANT SAFETY INFORMATION	3	OPERATING SEQUENCE	19
REQUIREMENTS & CODES	4	Cooling Mode	19
GENERAL INFORMATION	5	Blower Mode	19
About the Rooftop Unit	5	Heating Mode	19
Before You Install This Equipment	5	UNIT MAINTENANCE	19
Locating the Unit	5	Routine Maintenance	20
Heating Load	5	Motor / Bearing Lubrication Requirements	20
COMBUSTION AIR & VENTING REQUIREMENTS	6	Cleaning of Burners	20
General Information	7	Cleaning the Heat Exchanger	21
Vent Termination	7	Removal of Unit Top Pan	21
CIRCULATING AIR SUPPLY	8	REPLACEMENT PARTS	21
Air Ducts	8	COMPONENT FUNCTIONS	22
Air Filter Requirements	8	TROUBLESHOOTING	22
Unconditioned Spaces	9	FIGURES & TABLES	23
Acoustical Ductwork	9	Figure 11 - Location of Unit Components	23
UNIT INSTALLATION	9	Physical Dimensions	24
Packaging Removal	9	Figure 12 - R6GN 150/180 Series	24
Rigging & Hoisting	9	Table 3 - Unit Shipping Weights	25
Minimum Clearance Requirements	10	Blower Performance Data	26
Rooftop Mounting	10	Table 4 - R6GN 150 Series	26
Ground Level	10	Table 5 - R6GN 180 Series	27
Downflow to Horizontal Conversion	11	R6 Charging Charts	28
Condensate Drain	11	Figure 13 - R6GN-150 Series	28
GAS SUPPLY & PIPING	11	Figure 14 - R6GN-180 Series	29
Leak Check	12	Electrical Information	30
High Altitude Deration	12	Figure 15 - Ladder Diagram	30
Conversion to LP/Propane	13	Figure 16 - Wiring Diagram	31
ELECTRICAL WIRING	14	Table 6 - Electrical Data	32
Pre-Electrical Checklist	14	Gas Information	33
Line Voltage	14	Table 7- Gas Flow Rates	33
Grounding	14	Table 8 - Gas Pipe Capacities	33
Unbalanced 3-Phase Supply Voltage	15	Table 9 - Orifice or Drill Sizes for Nat. Gas	34
Thermostat / Low Voltage Connections	15	Table 10 - Orifice or Drill Sizes for LP Gas	34
Blower Speed	15	Table 11- Heating Rise / Range	34
Heat Anticipator	16	Figure 17 - Gas Valve Label	35
STARTUP & ADJUSTMENTS	16	INSTALLATION / PERFORMANCE CHECKLIST	36
Pre-Start Check List	16		
Startup Procedures	16		
Air Circulation	17		
System Cooling	17		
System Heating	17		
Verifying & Adjusting Temperature Rise	17		
Verifying Burner Operation	17		
Verifying Operation of Over-Temperature Limit Control	17		
Verifying & Adjusting Firing Rate	18		
Manifold Pressure Adjustment	18		
Refrigerant Charging	18		

IMPORTANT SAFETY INFORMATION

Please read all instructions before servicing this equipment. Pay attention to all safety warnings and any other special notes highlighted in the manual. Safety markings are used frequently throughout this manual to designate a degree or level of seriousness and should not be ignored.

WARNING indicates a potentially hazardous situation that if not avoided, could result in personal injury or death.

CAUTION indicates a potentially hazardous situation that if not avoided, may result in minor or moderate injury or property damage.

ATTENTION INSTALLERS: It is your responsibility to know this product better than your customer. This includes being able to install the product according to strict safety guidelines and instructing the customer on how to operate and maintain the equipment for the life of the product. Safety should always be the deciding factor when installing this product and using common sense plays an important role as well. Pay attention to all safety warnings and any other special notes highlighted in the manual. Improper installation of the unit or failure to follow safety warnings could result in serious injury, death, or property damage. These instructions are primarily intended to assist qualified individuals experienced in the proper installation of this appliance. Some local codes require licensed installation/service personnel for this type of equipment. After completing the installation, return these instructions to the customer's package for future reference.

WARNING:

Improper installation, service, adjustment, or maintenance may cause explosion, fire, electrical shock or other hazardous conditions which may result in personal injury or property damage. Unless otherwise noted in these instructions, only factory authorized kits or accessories may be used with this product.

WARNING:

Do not place combustible material on or against the unit cabinet. Do not place combustible materials, including gasoline and any other flammable vapors and liquids, in the vicinity of the unit.

WARNING:

PROPOSITION 65 WARNING: This product contains fiberglass wool, a product known to the state of California to cause cancer. Disturbing the insulation of this product during installation, maintenance, or repair will expose you to fiberglass wool.

- Breathing this material may cause respiratory irritations or may cause lung cancer.
 - Fiberglass wool may also cause eye irritation, skin sensitization, or other allergic responses in susceptible individuals.
 - Always wear goggles, disposable gloves, long sleeved shirt, and appropriate breathing protection when working near this insulation. If contact with skin occurs, wash immediately with soap and water. In case of contact with eyes, flush immediately with water for at least 15 minutes. Contact a physician if needed.
-

WARNING:

The information listed below and must be followed during the installation, service, and operation of this unit. Unqualified individuals should not attempt to interpret these instructions or install this equipment. Failure to follow safety recommendations could result in possible damage to the equipment, serious personal injury or death.

- This equipment contains liquid and gaseous refrigerant under high pressure. Installation or servicing should only be performed by qualified trained personnel thoroughly familiar with this type equipment.
- Before beginning the installation, verify that the unit model is correct for the job. The unit model number is printed on the data label. Follow all precautions in the literature, on tags, and on labels provided with the equipment. Read and thoroughly understand the instructions provided with the equipment prior to performing the installation and operational checkout of the equipment.
- Never test for gas leaks with an open flame. Use a commercially available soap solution to check all connections See pages 12 - 13.
- Follow all precautions in the literature, on tags, and on labels provided with the equipment. Read and thoroughly understand the instructions provided with the equipment prior to performing the installation and operational checkout of the equipment.
- This unit is designed only for outdoor installations and should be located with consideration of minimizing the

- length of the supply and return ducts. Consideration should also be given to the accessibility of fuel, electric power, service access, noise, and shade.
- The installer should become familiar with the units wiring diagram before making any electrical connections to the unit. See the unit wiring label or Figures 15 & 16 (pages 30 - 31).
 - Use caution when handling this appliance or removing components. Personal injury can occur from sharp metal edges present in all sheet metal constructed equipment.

REQUIREMENTS & CODES

- **This equipment must be installed in accordance with instructions outlined in this manual, all applicable local building codes, and the current revision of the National Fuel Gas Code (NFPA54/ANSI Z223.1) or the Natural Gas and Propane Installation Code, CAN/CGA B149.1.**
- All electrical wiring must be completed in accordance with local, state and national codes and regulations and with the National Electric Code (ANSI/NFPA 70) or in Canada the Canadian Electric Code Part 1 CSA C.22.1.
- The installer must comply with all local codes and regulations which govern the installation of this type of equipment. Local codes and regulations take precedence over any recommendations contained in these instructions. Consult local building codes and the National Electrical Code (ANSI CI) for special installation requirements.
- Air Ducts must be installed in accordance with the standards of the National Fire Protection Association “Standards for Installation of Air Conditioning and Ventilation Systems” (NFPA 90A), “Standard for Installation of Residence Type Warm Air Heating and Air Conditioning Systems” (NFPA 90B), these instructions, and all applicable local codes.
- Consult Table 11 (page 34), and the rating plate for the proper circulating air flow and temperature rise. It is important that the duct system be designed to provide the correct flow rates and external pressure rise. An improperly designed duct system can result in nuisance shutdowns, and comfort or noise issues.
- This unit is designed for outdoor installations only and should be located as described on page 10.
- Use only with the type of gas approved for this unit. Refer to the unit rating plate.
- Provide adequate combustion and ventilation air to the unit. See pages 6 - 7.
- Provide adequate clearances around the air vent intake terminal as specified on pages 7 - 8.

- Combustion products must be discharged outdoors. Connect this unit to an approved vent system only, as specified on pages 6 - 7.
- Additional codes listed below are for reference purposes only and do not necessarily have jurisdiction over local or state codes. Local codes and regulations take precedence over any recommendations contained in these instructions. Always consult with local authorities before installing any gas appliance.

Combustion & Ventilation Air

- US: National Fuel Gas Code (NFGC), Air for Combustion and Ventilation
- CANADA: Natural Gas and Propane Installation Codes (NSCNGPIC), Venting Systems and Air Supply for Appliances

Duct Systems

- US and CANADA: Air Conditioning Contractors Association (ACCA) Manual Q, Sheet Metal and Air Conditioning Contractors National Association (SMACNA), or American Society of Heating, Refrigeration, and Air Conditioning Engineers (ASHRAE) Fundamentals Handbook

Electrical Connections

- US: National Electrical Code (NEC) ANSI/NFPA 70
- CANADA: Canadian Electrical Code CSA C22.1

Gas Piping & Gas Pipe Pressure Testing

- US: NFGC and National Plumbing Codes
- CANADA: NSCNGPIC

General Installation

- US: Current edition of the NFGC and the NFPA 90B. For copies, contact the National Fire Protection Association Inc., Batterymarch Park, Quincy, MA 02269; or American Gas Association, 400 N. Capitol, N.W., Washington DC 20001 or www.NFPA.org.
- CANADA: NSCNGPIC. For a copy, contact Standard Sales, CSA International, 178 Rexdale Boulevard, Etobicoke (Toronto), Ontario, M9W 1R3 Canada

Safety

- US: (NFGC) NFPA 54–1999/ANSI Z223.1 and the Installation Standards, Warm Air Heating and Air Conditioning Systems ANSI/NFPA 90B.
- CANADA: CAN/CGA-B149.1–and .2–M00 National Standard of Canada. (NSCNGPIC)

GENERAL INFORMATION

About the Rooftop Unit

Single Package Gas Heating / Electric Cooling Rooftop Units are designed only for outdoor rooftop or ground level installations and can be readily connected to the duct system of a building. This unit has been tested for capacity and efficiency in accordance with AHRI Standards and will provide many years of safe and dependable comfort, providing it is properly installed and maintained. With regular maintenance, this unit will operate satisfactorily year after year. Abuse, improper use, and/or improper maintenance can shorten the life of the appliance and create unsafe hazards.

To achieve optimum performance and minimize equipment failure, it is recommended that periodic maintenance be performed on this unit. The ability to properly perform maintenance on this equipment requires certain tools and mechanical skills.

Before You Install this Equipment

- √ The cooling load of the area to be conditioned must be calculated and a system of the proper capacity selected. It is recommended that the area to be conditioned be completely insulated and vapor sealed.
- √ Check the electrical supply and verify the power supply is adequate for unit operation. Consideration should be given to availability of electric power, service access, noise, and shade. If there is any question concerning the power supply, contact the local power company.
- √ All units are securely packed at the time of shipment and upon arrival should be carefully inspected for damage prior to installing the equipment at the job site. Verify coil fins are straight. If necessary, comb fins to remove flattened or bent fins. Claims for damage (apparent or concealed) should be filed immediately with the carrier.
- √ Please consult your dealer for maintenance information and availability of maintenance contracts. Read all instructions before installing the unit.

Locating the Unit

- Survey the job site to determine the best location for the packaged unit. The unit should be located with consideration of minimizing the length of the supply and return ducts. If practical, place the equipment and its ducts in an area where they will be shaded from the afternoon sun, when the heat load is greatest. Consideration should also be given to the accessibility of fuel, electric power, service access, noise, and shade.
- Select a solid, level position, preferably on a concrete slab, slightly above the grade level, and parallel to the building.
- Overhead obstructions, poorly ventilated areas, and areas subject to accumulation of debris should be avoided. Do not place the unit in a confined space or recessed area where discharge air from the unit could re-circulate back through the condenser coil.
- Sufficient clearance for unobstructed airflow through the louvered control access panel and outdoor coil must be maintained in order to achieve rated performance. See Figure 5 (page 10) for minimum clearance requirements.
- A clearance of at least 48 inches from the blower access panel and from the louvered burner access panel is the required clearance to combustibles. Please refer to Figure 5 (page 10) for all requirements. **Where accessibility to combustibles clearances are greater than minimum clearances, accessibility clearances must take preference.**
- The hot condenser air must be discharged up and away from the home.
- If practical, place the air conditioner and its ducts in an area where they will be shaded from the afternoon sun, when the heat load is greatest.

Heating Load

This unit should be sized to provide the design heating load requirement. Heating load estimates can be made using approved methods available from Air Conditioning Contractors of America (Manual J); American Society of Heating, Refrigerating, and Air Conditioning Engineers; or other approved engineering methods. For installations above 2,000 ft., the unit should have a sea level input rating large enough that it will meet the heating load after deration for altitude.

COMBUSTION AIR & VENTING REQUIREMENTS

WARNING:

CARBON MONOXIDE POISONING HAZARD

Failure to follow the steps outlined below for each appliance connected to the venting system being placed into operation could result in carbon monoxide poisoning or death. The following steps shall be followed with each individual appliance connected to the venting system being placed in operation, while all other appliances connected to the venting system are not in operation:

1. Seal any unused openings in the venting system.
2. Inspect the venting system for proper size and horizontal pitch, as required in the National Fuel Gas Code, ANSI Z223.1/NFPA 54 or the CSA B149.1, Natural Gas and Propane Installation Codes and these instructions. Determine that there is no blockage or restriction, leakage, corrosion and other deficiencies which could cause an unsafe condition.
3. As far as practical, close all building doors and windows and all doors between the space in which the appliance(s) connected to the venting system are located and other spaces of the building.
4. Close fireplace dampers.
5. Turn on clothes dryers and any appliance not connected to the venting system. Turn on any exhaust fans, such as range hoods and bathroom exhausts, so they are operating at maximum speed. Do not operate a summer exhaust fan.
6. Follow the lighting instructions. Place the appliance being inspected into operation. Adjust the thermostat so appliance is operating continuously.
7. Test for spillage from draft hood equipped appliances at the draft hood relief opening after 5 minutes of main burner operation. Use the flame of a match or candle.
8. If improper venting is observed during any of the above tests, the venting system must be corrected in accordance with the National Fuel Gas Code, ANSI Z223.1/NFPA 54 and/or CSA B149.1, Natural Gas and Propane Installation Codes.
9. After it has been determined that each appliance connected to the venting system properly vents when tested as outlined above, return doors, windows, exhaust fans, fireplace dampers and any other gas-fired burning appliance to their previous conditions of use.

AVERTISSEMENT:

RISQUE D'EMPOISONNEMENT AU MONOXYDE DE CARBONE

Le non-respect des consignes suivantes portant sur chacun des appareils raccordés au système d'évacuation mis en service pourrait entraîner l'empoisonnement au monoxyde de carbone ou la mort. Les consignes suivantes doivent être observées pour chaque appareil raccordé au système d'évacuation mis en service si les autres appareils raccordés au système ne sont pas en service:

1. Sceller toute ouverture non utilisée de la système d'évacuation;
2. S'assurer que la système d'évacuation présente des dimensions et une pente horizontale conformes à la norme ANSI Z223.1/NFPA 54, intitulée National Fuel Gas Code ou aux codes d'installation CSA-B149.1, ainsi qu'aux présentes instructions. S'assurer que la système d'évacuation n'est pas bloquée, restreinte, corrodée, qu'elle ne fuit pas et qu'elle ne présente aucun autre défaut potentiellement dangereux;
3. Dans la mesure du possible, fermer toutes les portes et fenêtres du bâtiment, et toutes les portes entre la pièce où se trouve l'appareil raccordé à la système d'évacuation et les autres pièces du bâtiment.
4. Fermer les registres des foyers;
5. Mettre en service les sècheuses et tout autre appareil qui n'est pas raccordé à la système d'évacuation. Faire fonctionner à régime maximal tout ventilateur d'évacuation, tel que les hottes de cuisinière et les ventilateurs de salles de bains. Ne pas mettre en service les ventilateurs d'été.
6. Respecter les instructions d'allumage. Mettre en service l'appareil à l'essai. Régler le thermostat de manière à ce que l'appareil fonctionne sans interruption;
7. Vérifier s'il y a débordement à l'orifice d'évacuation du coupe tirage des appareils dotés d'un coupe tirage 5 minutes après l'allumage du brûleur principal. Utiliser la flamme d'une allumette ou d'une chandelle.
8. Si l'on constate, au cours de l'un des essais qui précèdent, que l'évacuation est déficiente, corriger le système d'évacuation conformément à la norm ANSI Z223.1/NFPA 54, National Fuel Gas Code, et (ou) aux codes d'installation CSA B149.1.
9. Après avoir déterminé que tous les appareils raccordés à la système d'évacuation évacuent correctement tel que prescrit ci-dessus, rouvrir les portes et les fenêtres et remettre les ventilateurs d'évacuation, les registres de foyers et tout autre appareil fonctionnant au gaz à leur état de fonctionnement initial.

General Information

⚠ WARNING:

Installation methods other than those described in the following sections must comply with the National Fuel Gas Code and all applicable local codes for providing sufficient combustion air to the furnace.

Provisions must be made during the installation of this unit that provide an adequate supply of air for combustion.

- Instructions for determining the adequacy of an installation can be found in the current revision of the NFGC (ANSI Z223.1 / NFPA54). **Consult local codes for special requirements.** These requirements are for US installations as found in the NFGC.
- The requirements in Canada (B149.1) are structured differently. Consult with B149.1 and local code officials for Canadian installations.

⚠ WARNING:

Combustible air must not be drawn from a contaminated atmosphere. Excessive exposure to contaminated combustion air will result in safety and performance related problems.

To maximize heat exchanger life, the combustion air must be free of chemicals that can form corrosive acidic compounds in the combustion gases. The recommended source of combustion air is to use clean air from outside. **DO NOT place any chemicals with flammable or caustic vapors or these other corrosive chemicals near the vent termination:**

- Gasoline/Kerosene
- Permanent wave solutions
- Chlorinated waxes and cleaners
- Chlorine based swimming pool chemicals
- Water softening chemicals
- De-icing salts or chemicals
- Carbon tetrachloride
- Halogen type refrigerants
- Cleaning solvents
- Cements, glues, paint removers, varnishes, etc.
- Hydrochloric acid
- Masonry acid washing materials

Air openings in the door of the unit, warm air registers, and return air grilles must never be restricted. If the unit does not receive an adequate supply of air for combustion, the flame roll-out control located above the burners will open, turning off the gas supply to the burners. This safety device is a manually reset switch. **IMPORTANT NOTE!: DO NOT install jumper wires across this control to defeat its function or reset the control without identifying and correcting the fault condition.**

If this control must be replaced, use only factory authorized replacement parts. See the Replacement Parts List on page 21.

Vent Termination

This unit has been equipped with an integral venting system and designed to operate only with this venting system. No additional venting shall be used. **This unit must be vented to the outdoors.**

⚠ WARNING:

This unit is intended for outdoor installation only. Do not vent the unit through a conventional venting system.

A vent cover assembly has been supplied with the unit and can be found secured to the gas controls within the control area of this unit. Figure 1 shows the proper installation of the vent cover assembly over the vent outlet on the exterior of the corner panel. The fasteners used to secure the vent cover assembly have been included in the owner's package. **The vent cover assembly must be installed to assure proper operation of the unit.**

The list below summarizes the location requirements for the venting system termination:

- The location of the vent termination must be consistent with the National Fuel Gas Code (ANSI Z223.1) or CAN/CGA-B149 Installation Codes.
- Must be located at least 4 feet horizontally from any electric meters, gas meters, regulators, and relief equipment.
- Must be located at least 3 feet above any forced air inlet located within 10 feet of unit.
- Must be located at least 4 feet below, 4 feet horizontally from, or 1 foot above any door, window, or gravity air inlet into any building.
- Must be located at least 1 foot above grade and installed in such a manner as to prevent snow accumulation from obstructing the vent termination.
- The vent termination must not be located above any public walkways.

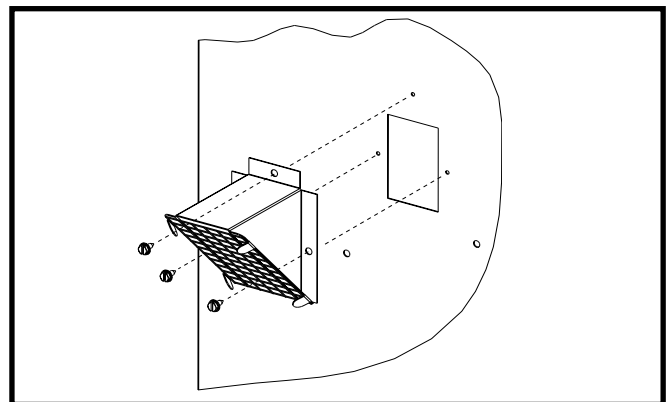

Figure 1. Vent Cover Assembly

- Make sure that the exhaust gases will not impinge on windows or building surfaces, which may be compromised or damaged by condensation.
- Do not install the unit in a location where exhaust from the vent termination will be directed into windows, stairwells, under decks, or other recessed areas.

CIRCULATING AIR SUPPLY

WARNING:

Do not allow combustion products to enter the return air ductwork or the circulating air supply. Failure to prevent the circulation of combustion products into the living space can create potentially hazardous conditions including carbon monoxide poisoning that could result in personal injury or death.

All return ductwork must be secured to the unit with sheet metal screws. All return ductwork must be adequately sealed and all joints must be taped. When return air is provided through the bottom of the unit, the joint between the unit and the return air plenum must be air tight.

The roof curb or cement pad on which the unit is mounted must provide sound physical support of the unit with no gaps, cracks, or sagging between the unit and the curb or pad.

Return air and circulating air ductwork must not be connected to any other heat producing device such as a fireplace insert, stove, etc. Doing so may result in fire, explosion, carbon monoxide poisoning, personal injury, or property damage.

Air Ducts

This unit is designed only for use with a supply and return duct. Air ducts should be installed in accordance with the standards of the National Fire Protection Association “Standard for Installation of Air Conditioning Systems” (NFPA 90A), “Standard for Installation of Residence Type Warm Air Heating and Air Conditioning Systems” (NFPA 90B), and all applicable local codes. NFPA publications are available by writing to: National Fire Protection Association, Batterymarch Park, Quincy, ME 02269 or visit www.nfpa.org on the web.

- Design the duct work according to Manual Q by the Air Conditioning Contractors of America (ACCA).
- The ducts must be properly sized and not exceed 0.2” W.C. pressure drop at 400 scfm per nominal ton of cooling capacity.

- Duct work should be attached directly to the unit flanges for horizontal applications.
- If roof curb is installed, the ducts must be attached to the curb hangers, not the unit.
- It is recommended that the outlet duct be equipped with a removable access panel. This opening should be accessible when the unit is installed in service and shall be of a size such that the smoke or reflected light may be observed inside the casing to indicate the presence of leaks in the heat exchanger. The cover for the opening shall be attached in such a manner as to prevent leaks.
- If outside air is utilized as return air to the unit for ventilation or to improve indoor air quality, the system must be designed so that the return air to the unit is not less than 50° F (10° C) during heating operation.
- If a combination of indoor and outdoor air is used, the ducts and damper system must be designed so that the return air supply to the furnace is equal to the return air supply under normal, indoor return air applications.

Air Filter Requirements

WARNING:

Never operate the unit without a filter in place. Dust and lint could accumulate on internal parts, resulting in loss of efficiency, equipment damage and possible fire.

- All return air must pass through the filters before entering the evaporator coil. It is important that all filters be kept clean and replaced frequently to ensure proper operation of unit. Dirty or clogged filters will reduce the efficiency of the unit and result in unit shutdowns. Refer to Table 1 for recommended filter sizes.
- Air filter pressure drop must not exceed 0.08 inches WC.

UNIT	FACTORY FILTER SIZE	QTY
R6GN-150(C,D)-(180, 270)C	16x20x2	8
R6GN-180(C,D)-(270, 315)C	16x20x2	8

Table 1. Filter Sizes & Quantities

Unconditioned Spaces

All duct work passing through unconditioned space must be properly insulated to minimize duct losses and prevent condensation. Use insulation with an outer vapor barrier. Refer to local codes for insulation material requirements.

Acoustical Duct Work

Certain installations may require the use of acoustical lining inside the supply duct work.

- Acoustical insulation must be in accordance with the current revision of the Sheet Metal and Air Conditioning Contractors National Association (SMACNA) application standard for duct liners.
- Duct lining must be UL classified batts or blankets with a fire hazard classification of FHC-25/50 or less.
- Fiber duct work may be used in place of internal duct liners if the fiber duct work is in accordance with the current revision of the SMACNA construction standard on fibrous glass ducts. Fibrous duct work and internal acoustical lining must be NFPA Class 1 air ducts when tested per UL Standard 181 for Class 1 ducts.

UNIT INSTALLATION

Packaging Removal

1. Remove top crate brackets and wooden cap assembly from top of unit (Figure 2).
2. Remove lower crate brackets, four side skids, and two end skids from each side of unit. **NOTE:** DO NOT remove base rails from unit.
3. Remove crate brackets (Figure 3) securing four bottom boards to underside of unit. **NOTE:** Some screws are located in fork slots.
4. Remove bottom boards from beneath unit.
5. Inspect unit thoroughly for shipping damage.
6. Carefully lower and position unit to its permanent location.

Rigging & Hoisting

WARNING:

To avoid the risk of property damage, personal injury, or death, it is the rigger's responsibility to ensure that whatever means are used to hoist the unit are safe and adequate:

- The lifting equipment must be adequate for the load. Refer to Table 3 (page 25) for unit weights.
- The unit must be lifted from the holes in the base rails using cables or chains.
- Spreader bars are required to protect the unit and ensure even loading. See Figure 4.
- Keep the unit in an upright position at all times. The rigging must be located outside the units center of gravity. Refer to Figure 12 (page 24) for locating the center of gravity.
- All panels must be securely in place during rigging and hoisting.

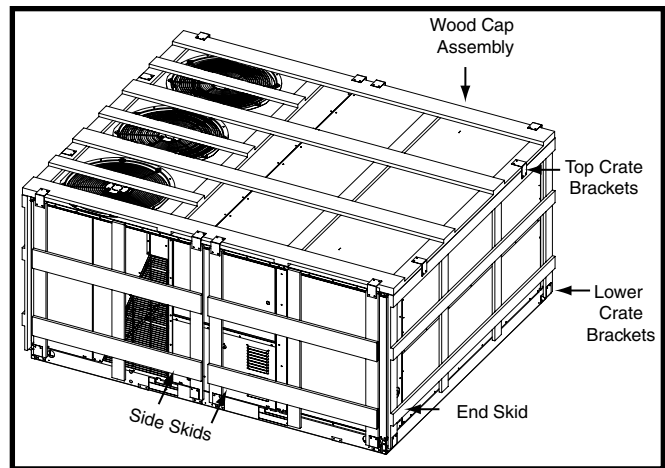

Figure 2. Side View

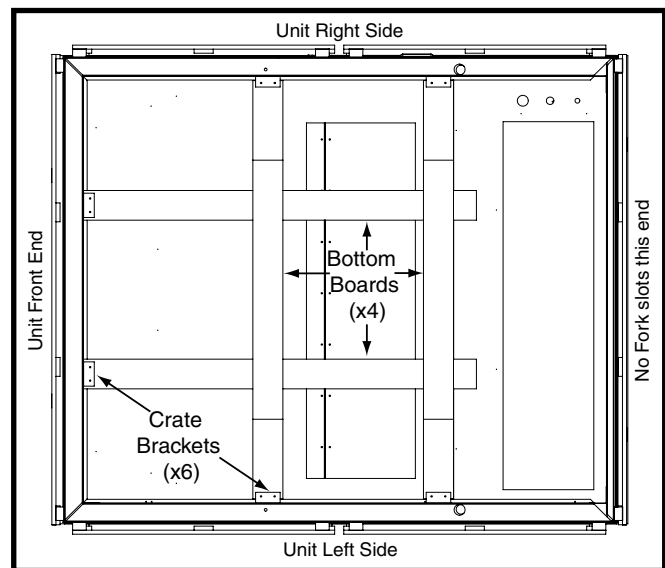

Figure 3. Bottom View

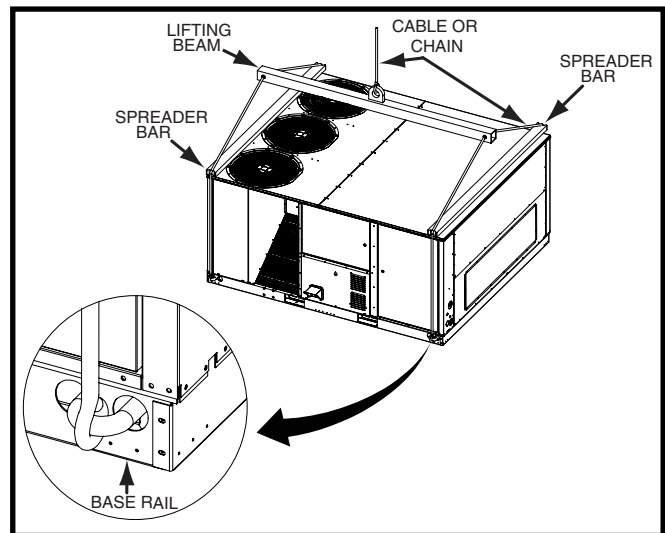

Figure 4. Rigging & Hoisting

Minimum Clearance Requirements

R6GN units are certified as combination heating and cooling equipment for outdoor installation only. Figure 5 displays the minimum clearances to combustible materials for both downflow and horizontal discharge.

R6GN units may be installed on wood flooring or on Class A, B, or C roof covering material when used with bottom supply and return air ducts as long as the following requirements are met:

- If using horizontal supply and return air ducts, the horizontal roof curb kit and return air kit must be installed prior to unit installation. Horizontal roof curb is required.
- If using bottom discharge with return air ducts a roof curb must be installed prior to unit installation. See Rigging and Hoisting section (page 9) for setting of the unit.

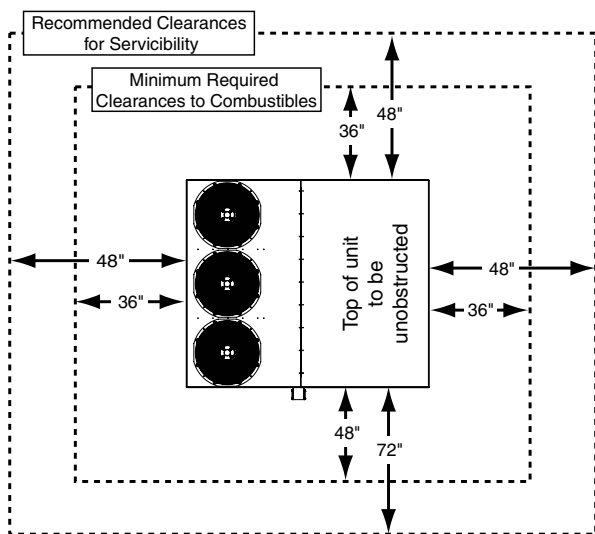

Figure 5. Unit Clearance Requirements

Rooftop Mounting

Rooftop installations must be located according to local building codes or ordinances and these requirements:

- The roof must be capable of handling the weight of the unit. For unit weights, see Table 3 (page 25). Reinforce the roof if necessary.
- The appropriate accessory roof curb (Figure 6) must be installed prior to unit installation. The roof curb must be square and level to ensure proper condensate drainage. **Please follow all instructions provided with the kit.**

WARNING:

Never drill or punch holes in unit base when installing downflow units. Leakage may occur if bottom pan is punctured.

- On bottom discharge applications, the supply and return air ducts must be attached to the roof curb duct supports, not the unit. Install all ductwork before setting unit on curb or frame.

- Frame support must be constructed using non-combustible materials. Full perimeter support is required under the unit. Supports must be made of steel or weather resistant wooden materials. The unit must be square and level to ensure proper condensate drainage.
- The frame must be high enough to ensure prevention of any moisture from entering the unit. Recommended height to unit base is 8" (20cm) for both Downflow and Horizontal installations.
- Secure roof curb or frame to roof using acceptable mechanical methods per local codes.

Ground Level

Ground level installations must be located according to local building codes or ordinances and these requirements:

- Clearances must be in accordance with those shown in Figure 5.
- A concrete mounting pad (Figure 7) must be provided and separate from the building foundation. The pad must be level to ensure proper condensate disposal and strong enough to support the unit's weight. The slab height must be a minimum of 3" (8cm) above grade and with adequate drainage.
- Units require horizontal roof curb and return air kit for horizontal installations.
- Ductwork should be attached directly to flanges on panels supplied in horizontal duct conversion kits.

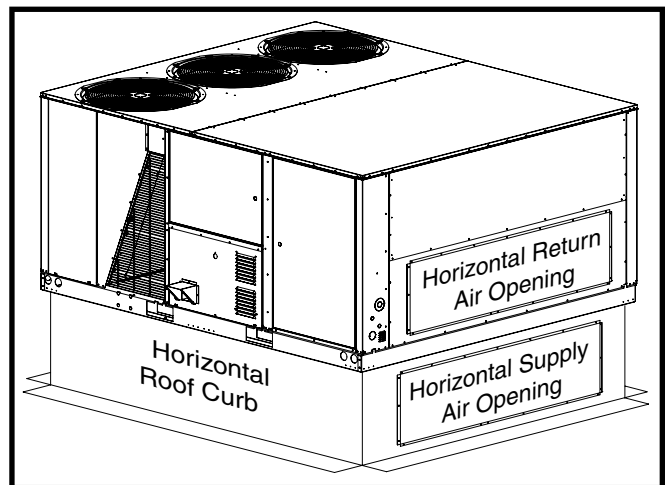

Figure 6. Horizontal Roof Curb

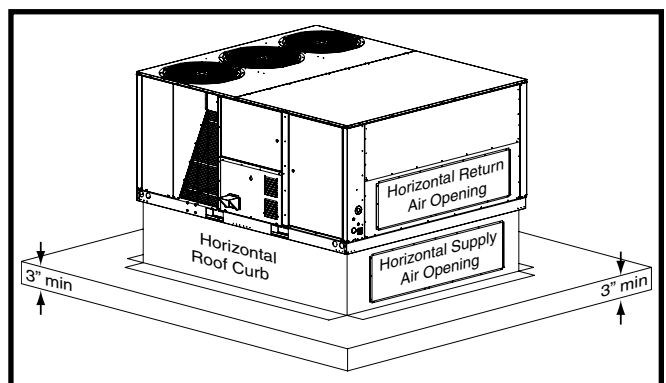

Figure 7. Concrete Mounting Pad

Downflow to Horizontal Conversion

The unit is shipped ready for downflow duct connections. If horizontal ducts are required, the unit must be converted according to the directions in the conversion kit for both the supply and return ducts.

Condensate Drain

The method for disposing of condensate varies according to local codes. Consult your local code or authority having jurisdiction.

Condensate is drained from the unit through one of two 3/4" (19mm) PVC female threaded fittings located on each side of the unit (Figure 8). One inside the bottom of the filter access area and one at the bottom of the control panel area. Both are accessible through the base rail using a straight length of 3/4" pipe equipped with a 3/4" threaded male fitting. When connecting rigid drain line, hold any fittings with a wrench to prevent twisting. **Do not overtighten!**

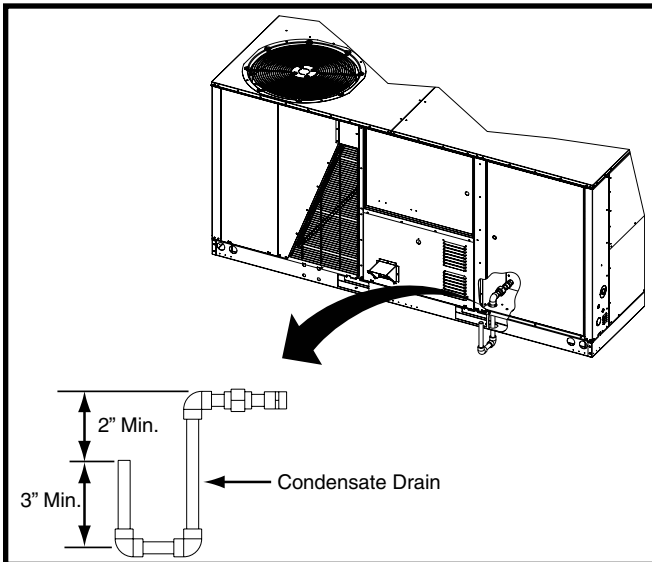

Figure 8. Condensate Drain

GAS SUPPLY & PIPING

WARNING:

FIRE OR EXPLOSION HAZARD

- Failure to follow safety warnings exactly could result in serious injury or property damage.
- Installation and service must be performed by a qualified installer, service agency or the gas supplier.
- Do not store or use gasoline or other flammable vapors and liquids in the vicinity of this or any other appliance.

WHAT TO DO IF YOU SMELL GAS

- Do not try to light any appliance.
- Do not touch any electrical switch; do not use any phone in your building.
- Leave the building immediately.
- Immediately call your gas supplier from a neighbor's phone. Follow the gas supplier's instructions.
- If you cannot reach your gas supplier, call the fire department.

AVERTISSEMENT:

RISQUE D'INCENDIE OU D'EXPLOSION

- Le non-respect des avertissements de sécurité pourrait entraîner des blessures graves, la mort ou des dommages matériels.
- L'installation et l'entretien doivent être effectués par un installateur qualifié, un organisme de service ou le fournisseur de gazstaller, service agency or the gas supplier.
- Ne pas entreposer ni utiliser de l'essence ni d'autres vapeurs ou liquides inflammables dans le voisinage de cet appareil, ni de tout autre appareil.

QUE FAIRE S'IL Y A UNE ODEUR DE GAZ

- Ne pas tenter d'allumer aucun appareil.
- Ne toucher à aucun interrupteur électrique; n'utiliser aucun téléphone dans le bâtiment.
- Évacuer l'immeuble immédiatement.
- Appeler immédiatement le fournisseur de gaz en employant le téléphone d'un voisin. Respecter à la lettre les instructions du fournisseur de gaz.
- Si personne ne répond, appeler le service des incendies.

IMPORTANT NOTES:

- All gas piping must be installed in compliance with local codes and utility regulations. In the absence of local codes the gas line installation must comply with the latest edition of the National Fuel Gas Code ANSI Z223.1 or CAN/CGA B149 Installation Codes.
- Some local codes require the installation of a manual main shut-off valve and ground joint union external to the furnace (Figure 9, page 13). The shut-off valve should be readily accessible for service and/or emergency use. Consult the local utility or gas supplier for additional requirements regarding placement of the manual main gas shut-off.
- Gas piping must never run in or through air ducts, chimneys, gas vents, or elevator shafts.
- Compounds used to seal joints on gas piping must be resistant to the actions of LP propane gas.
- The main gas valve and main power disconnect to the furnace must be properly labeled by the installer in case emergency shutdown is required.
- An 1/8 inch NPT plugged tap must be installed in the gas line immediately upstream of the gas supply connection to the furnace for use when measuring the gas supply pressure. The plug should be readily accessible for service use.
- A drip leg should be installed in the vertical pipe run to the unit (Figure 9).

This unit is shipped from the factory for natural gas operation at sea level elevation and is equipped with a 1/8 orifice/drill size at each burner. Table 9 (page 33), lists gas pipe capacities for standard pipe sizes as a function of length in typical applications based on nominal pressure drop in the line.

This unit only has right side gas entry. When connecting the gas, provide clearance between the gas supply line and the entry hole in the unit's casing to avoid unwanted noise and/or damage to the unit. A typical gas service hookup is shown in Figure 9.

Leak Check

WARNING:

FIRE OR EXPLOSION HAZARD

Failure to follow safety warnings exactly could result in serious injury or property damage.

Never test for gas leaks with an open flame. Use a commercially available soap solution made specifically for the detection of leaks to check all connections. A fire or explosion may result causing property damage, personal injury or loss of life.

AVERTISSEMENT:

RISQUE D'INDENNIE OU D'EXPLOSION

Le non-respect des avertissements de sécurité pourrait d'entraîner des blessures graves, la mort ou des dommages matériels.

Ne jamais utiliser une flamme nue pour vérifier la présence des fuites de gaz. Pour la vérification de tous les joints, utiliser plutôt une solution savonneuse commerciale fabriquée spécifiquement pour la détection des fuites de gaz. Un incendie ou une explosion peut entraîner des dommages matériels, des blessures ou la mort.

After the gas piping to the unit is complete, all connections must be tested for gas leaks. This includes pipe connections at the main gas valve, emergency shutoff valve and other gas connectors.

The soap and water solution can be applied on each joint or union using a small paintbrush. If any bubbling is observed, the connection is not sealed adequately and must be retightened. Repeat the tightening and soap check process until bubbling ceases.

IMPORTANT NOTES!

- **If pressure testing the gas supply lines at pressures greater than 1/2 psig (14 inches WC), the unit must be disconnected from the gas supply piping system to prevent damage to the gas valve.**
- **If the test pressure is less than or equal to 1/2 psig (14 inches WC), the unit must be isolated from the gas supply line by closing the manual shut-off valve.**

High Altitude Deration

High altitude application with this unit depends on the installation altitude and the heating value of the gas. At high altitudes, the heating value of natural gas is always lower than the heating value at sea level.

All installations of this equipment must be made in accordance with the National Fuel Gas Code or with local jurisdiction codes. For installations at exactly 2,000 feet in altitude or under, the installer does not need to derate the heat exchanger performance. For any installation that exceeds 2,000 feet, please use the following instructions and example on page 13.

WARNING:

The reduction of input rating necessary for high altitude installation may only be accomplished with factory supplied orifices. Do not attempt to drill out orifices in the field. Improperly drilled orifices may cause fire, explosion, carbon monoxide poisoning, personal injury or death.

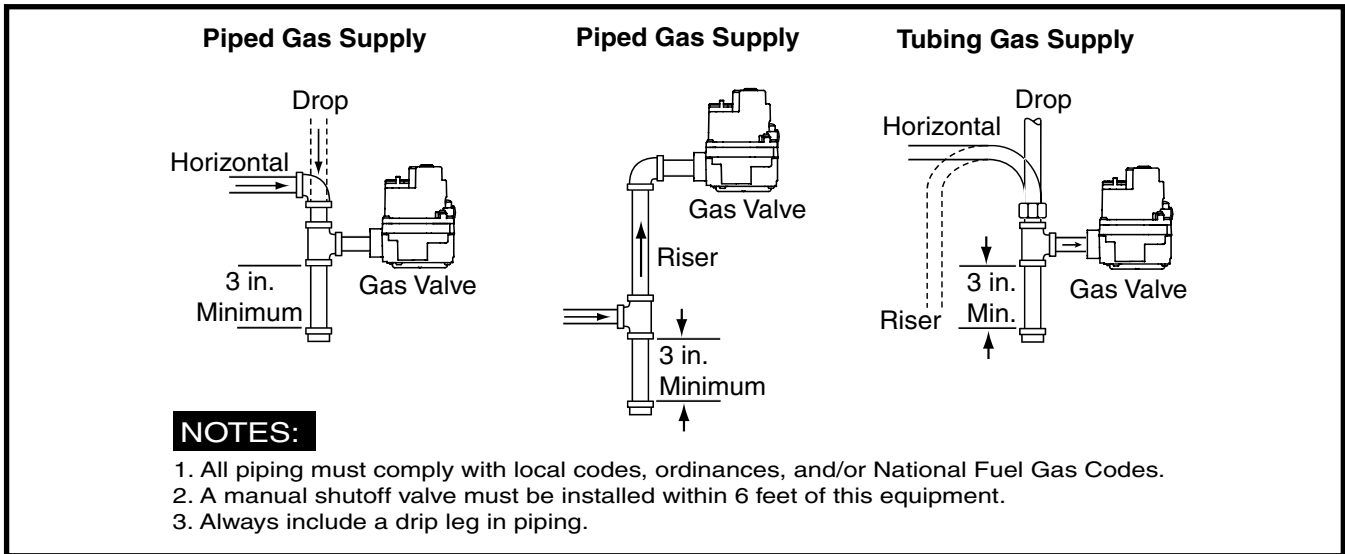

Figure 9. Typical Gas Service Connection

- If installing this unit above 2,000 feet, the input rate must be reduced 4% per 1,000 feet of altitude (Example: 12% at 3,000 feet, 16% at 4,000 feet, etc). Always round up to the next highest value of 1,000. So an installation at 3,120 feet is derated by 16% due to rounding up to 4,000. NOTE: This deration is necessary to compensate for low atmospheric pressure at high altitudes. Generally this will require obtaining the gas heating value from the local gas utility and replacing the burner orifices.
- Tables 9 & 10 (page 34) list the correct orifice size and high elevation conversion kit approved for this unit at various altitudes. Use the Installation Example below to determine the unit rating and orifice size.
- After changing the orifices, it is required that you measure the gas input rate by clocking the gas meter and using the local gas heating value. See Verifying & Adjusting the Firing Rate (page 16).

IMPORTANT NOTE! Observe the action of the burners to make sure there is no yellowing, lifting or flashback of the flame.

Conversion to LP/Propane

⚠ WARNING:

The furnace was shipped from the factory equipped to operate on natural gas. Conversion to LP/propane gas must be performed by qualified service personnel using a factory supplied conversion kit. Failure to use the proper conversion kit can cause fire, explosion, property damage, carbon monoxide poisoning, personal injury, or death.

In the U.S., if installing the unit above 2,000 ft., refer to Table 10 (page 34) to determine the correct orifice size. When conversion is complete, verify the input rate is correct as listed in the table. **Please follow the instructions provided with each kit.**

- The United States LP/Propane Gas Sea Level and High Altitude Conversion Kit is for LP/propane conversion in the United States at altitudes between 2,000 ft. and 7,000 ft. above sea level.
- The Canadian LP/Propane Gas Sea Level and High Altitude Conversion Kit is for LP/propane conversions in Canada at altitudes between zero and 4,500 ft. above sea level.

INSTALLATION EXAMPLE:

Elevation:3,890 feet
Type of Gas: Natural
Unit Model: R6GN-150C270C

At 4,000 feet, the unit needs to be derated by 4% for each 1,000 feet of elevation. This equates to 16% or less than the sea level rating of 270,000 Btu/h.

1. Determine unit input rating:
 $[270k \times (100-16)\%] = 226,800 \text{ Btu/h}$. The required heating rate for 3,890 feet is 226,800 Btu/h.
2. Determine orifice size:
 From Table 9 (page 34), find the Unit Model Number. Follow across the row and stop at the 2,000-4,000 elevation column. For this example, the orifice size displayed is #31. Install one #31 orifice in every burner and check firing rate. In this example, the firing rate must not exceed 226,800 Btu/h.

ELECTRICAL WIRING

WARNING:

ELECTRICAL SHOCK, FIRE OR EXPLOSION HAZARD

Failure to follow safety warnings exactly could result in serious injury or property damage.

Improper servicing could result in dangerous operation, serious injury, death or property damage.

- **Before servicing, disconnect all electrical power to furnace.**
- **When servicing controls, label all wires prior to disconnecting. Reconnect wires correctly.**
- **Verify proper operation after servicing.**

AVERTISSEMENT:

RISQUE DE CHOC ÉLECTRIQUE, D'INCENDIE OU D'EXPLOSION

Le non-respect des avertissements de sécurité pourrait entraîner un fonctionnement dangereux de l'appareil, des blessures graves, la mort ou des dommages matériels.

Un entretien incorrect pourrait entraîner un fonctionnement dangereux de l'appareil, des blessures graves, la mort ou des dommages matériels

- **Couper toute alimentation électrique au générateur d'air chaud avant de prodéder aux travaux d'entretien.**
- **Au moment de l'entretien des commandes, étiquetez tous les fils avant de les débrancher. S'assurer de les raccorder correctement.**
- **S'assurer que l'appareil fonctionne adéquatement après l'entretien.**

Pre-Electrical Checklist

- √ Verify that the voltage, frequency, and phase of the supply source match the specifications on the unit rating plate.
- √ Verify that the service provided by the utility is sufficient to handle the additional load imposed by this equipment. See Table 6 (page 32) or the unit wiring label for proper high and low voltage wiring.
- √ Verify factory wiring is in accordance with the unit wiring diagram (Figures 15 & 16, pages 30 & 31). Inspect for loose connections.
- √ For 3 phase units always check the phase balance (page 15).

Line Voltage

- Electrical connections must be in compliance with all applicable local codes and ordinances, and with the current revision of the National Electric Code (ANSI/NFPA 70). For Canadian installations the electrical connections and grounding shall comply with the current Canadian Electrical Code (CSA C22.1 and/or local codes).
- Provide power supply for the unit in accordance with the unit wiring diagram and the unit rating plate. The line voltage to the unit should be supplied from a dedicated branch circuit containing the correct fuse or circuit breaker for the unit.
- **An electrical disconnect must be located within sight of and readily accessible to the unit.** This switch shall be capable of electrically de-energizing the outdoor unit. See unit data label for proper incoming field wiring. Any other wiring methods must be acceptable to authority having jurisdiction.
- A wiring diagram is located on the inside cover of the control access panel of the outdoor unit. The installer should become familiar with the wiring diagram before making any electrical connections to the outdoor unit. See Figures 15 & 16.
- If any of the original wires supplied with the unit must be replaced, they must be replaced with material of the same gauge and temperature rating.
- Connect the line-voltage leads to the terminals on the contactor inside the control compartment.
- Use only copper wire for the line voltage power supply to this unit. Use proper code agency listed conduit and connector for connecting the supply wires. Use of rain tight conduit is recommended.
- Units are shipped from the factory wired for 230 or 460 volt operation. On 208-230V units being placed into 208 volt operation, remove the lead from the transformer terminal marked 240V and connect it to the terminal marked 208V.
- Overcurrent protection must be provided at the branch circuit distribution panel and sized as shown on the unit rating label and according to the National Electric Code and applicable local codes. **NOTE:** See the unit rating plate for maximum circuit ampacity and maximum overcurrent protection limits.

Grounding

WARNING:

The unit cabinet must have an uninterrupted or unbroken electrical ground to minimize personal injury if an electrical fault should occur. Do not use gas piping as an electrical ground!

This unit must be electrically grounded in accordance with local codes or, in the absence of local codes, with the National Electrical Code (ANSI/NFPA 70) or the CSA C22.1 Electrical Code. Use the grounding lug provided in the control box for grounding the unit.

Unbalanced 3-Phase Supply Voltage

Voltage unbalance occurs when the voltages of all phases of a 3-phase power supply are no longer equal. This unbalance reduces motor efficiency and performance. Some underlying causes of voltage unbalance may include: Lack of symmetry in transmission lines, large single-phase loads, and unbalanced or overloaded transformers. A motor should never be operated when a phase imbalance in supply is greater than 2%. Perform the following steps to determine the percentage of voltage imbalance:

1. Measure the line voltages of your 3-phase power supply where it enters the building and at a location that will only be dedicated to the unit installation (at the units circuit protection or disconnect).

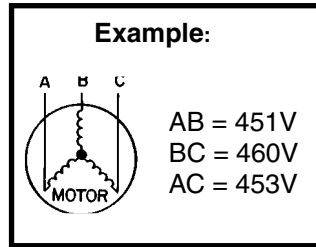

2. Determine the average voltage in the power supply.

In this example, the measured line voltages were 451, 460, and 453. The average would be 454 volts $(451 + 460 + 453 = 1,364 / 3 = 454)$.

3. Determine the maximum deviation:

Example:
From the values given in step 1, the BC voltage (460V) is the greatest difference in value from the average:
 $460 - 454 = 6$ ← Highest Value
 $454 - 451 = 3$
 $454 - 453 = 1$

4. Determine percent of voltage imbalance by using the results from steps 2 & 3 in the following equation.

Example:

$$100 \times \frac{6}{454} = 1.32\%$$

$$\% \text{ Voltage Imbalance} = 100 \times \frac{\text{max voltage deviation from average voltage}}{\text{average voltage}}$$

The amount of phase imbalance (1.32%) is satisfactory since the amount is lower than the maximum allowable 2%. Please contact your local electric utility company if your voltage imbalance is more than 2%.

Thermostat / Low Voltage Connections

- Single Package Gas Heating / Electric Cooling Rooftop Units are designed to operate with a 24 VAC Class II control circuit. The control circuit wiring must comply with the current provisions of the NEC (ANSI/NFPA 70) and with applicable local codes having jurisdiction. Thermostat connections should be made in accordance with the instructions supplied with the thermostat and the indoor equipment.

- A two-stage heating/cooling thermostat is required for R6GN series units. Select a thermostat which operates in conjunction with the installed accessories. The thermostat should be mounted about 5 feet above the floor on an inside wall. See Figure 10 for proper wire gauge and their recommended lengths for typical thermostat connections.
- The low voltage wires must be properly connected to the units low voltage terminal block. Route 24V control wires through the gas furnace side of the unit. Recommended wire gauge and wire lengths for typical thermostat connections are shown in Figure 10.
- The thermostat should be mounted about 5 feet above the floor on an inside wall. **DO NOT** install the thermostat on an outside wall or any other location where its operation may be adversely affected by radiant heat from fireplaces, sunlight, or lighting fixtures, and convective heat from warm air registers or electrical appliances. Refer to the thermostat manufacturer's instruction sheet for detailed mounting information.

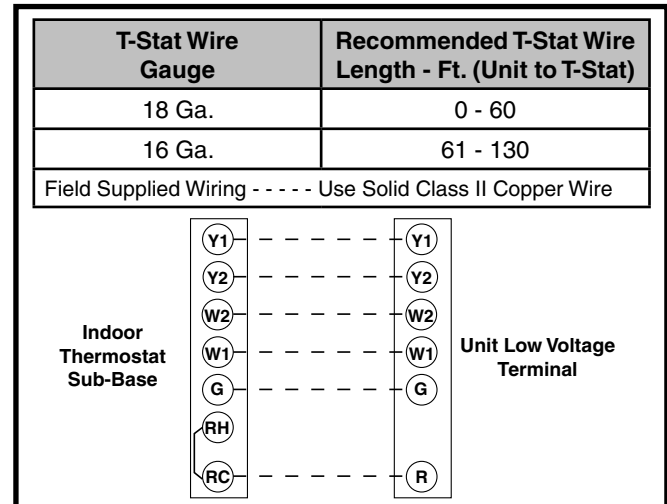

Figure 10. Typical 2 - Stage Heat/Cool Thermostat Connection

Blower Speed

The blower speed is preset at the factory but must be verified at each installation. For optimum system performance and comfort, it may be necessary to change the factory set speed. Refer to the Blower Performance Data (Tables 5 & 6, pages 26 & 27) for proper operating range. Always inspect variable pitch sheaves for proper tightness and set screws

CAUTION:

To avoid personal injury or property damage, make sure the motor leads do not make contact with any uninsulated metal components of the unit.

To change the blower speed:

1. Disconnect all electrical power to the unit.
2. Open the motor access panel.
3. Loosen the 4 motor mounting nuts. Turn the belt tensioning nut until belt can be removed from the sheave or pulley.
4. Loosen front set screw on the motor sheave.
NOTE: Turning the set screw clockwise (close) increases the blower speed, or counterclockwise (open) decreases blower speed.
5. Replace belt on pulleys and position motor mounting plate to correct position for proper belt tension. Note: Make sure the pulley, belt, and motor sheave are properly aligned.
6. Tighten the four motor mounting nuts. Verify the drive belt is secure and tensioned properly.

Heat Anticipator

Verify if the thermostat being used for the installation has a heat anticipator setting. This function allows the thermostat to anticipate the space heating rate and time the burner to shutoff accordingly. Always refer to the thermostat manufacturers instructions for the correct settings.

STARTUP & ADJUSTMENTS

Pre-Start Check List

- √ Verify unit is properly supported.
- √ Verify unit is level for proper condensate drainage.
- √ Verify all clearance requirements are met. Airflow to and from the outdoor coil must be unrestricted.
- √ Verify the ductwork is adequately sealed to prevent air leakage. Insulate if necessary.
- √ Verify the line voltage power leads are securely connected and the unit is properly grounded.
- √ Verify low voltage wires are securely connected to the correct leads in the control box.
- √ Verify gas line pressure. For natural gas, the line pressure must not exceed 10.0 inches WC (0.36 psig), or be less than 5.5 inches WC (0.20 psig). For LP gas, the line pressure must not exceed 14 inches WC (0.51 psig) and must not be less than 11.0 inches WC (0.40 psig).
- √ Verify the flame roll-out control is closed.

IMPORTANT NOTE! This safety device is a manually reset switch. If necessary, press the red button to reset the control. DO NOT install a jumper wire across the control to defeat its function. If the control reopens upon start-up, DO NOT reset the control without identifying and correcting the fault condition which caused the control to trip.

- √ Verify the gas line has been purged and all connections are adequately sealed. To check for gas leakage, see Leak Check section on page 12.
- √ Verify the indoor blower is properly set for the installation.
- √ Verify the outdoor fan turns freely.
- √ Verify the power supply branch circuit overcurrent protection is properly sized.
- √ Verify all exterior panels have been reinstalled and securely fastened.
- √ Verify the thermostat is wired correctly and preset for initial operation. Set the thermostat system switch to OFF and the fan switch to AUTO.

Startup Procedures

WARNING:

This unit is equipped with crankcase heaters. Allow 24 hrs for heating of the refrigerant compressor crankcase prior to start up and anytime the power has been removed for more than 12 hrs. Failure to comply may result in damage or cause premature failure of the system.

- Check all electrical wiring for loose connections and tighten as required.
- Check unit for return air filters and condensate trap.
- Close all electrical disconnects to energize the system.

Air Circulation

1. Set the thermostat switch to OFF and the fan switch to ON.
2. Verify the blower motor runs continuously. Check for air delivery at the register(s). Ensure that there are no obstructions at the registers or in the ductwork.
3. Set thermostat fan switch to AUTO and verify the blower shuts down immediately.

NOTE: If blower is turning opposite of arrow direction, shut off main power to the unit and switch any two field wires at the disconnect. **DO NOT** alter unit wiring.

System Cooling

1. Set the thermostat system switch to COOL and the fan switch to AUTO.
2. Lower the thermostat temperature switch below room temperature and observe that the blower, both compressors and fans energize.
3. Verify blower is turning in direction indicated by arrow and air discharged at the register is cooler than room temperature.
4. Verify HI & LO refrigerant pressures.

NOTE: If refrigerant pressures are abnormal and blower is rotating in the opposite direction of the arrow, shut off main power to the unit and switch any two field wires at the disconnect. Ensure proper rotation of the blower. **DO NOT** alter unit wiring. Listen for any unusual noises. Locate the source and correct as needed.

5. Allow the unit to run for several minutes. Set the temperature selector above room temperature and verify that the fan, blower, and compressors cycle off with the thermostat.

System Heating

1. Set the thermostat to the lowest setting.
2. Follow the startup procedures on this page or the operating instruction label inside the louvered control access panel.
3. Set the thermostat above room temperature and verify the Operating Sequence (page 19).
4. Verify that the compressor and outdoor fan motor are not energized.
5. Run the unit and after approximately five minutes, set the thermostat below room temperature. Verify the shutdown sequence (steps 7 - 8 of the Operating Sequence).

Verifying & Adjusting Temperature Rise

Verify the temperature rise through the unit is within the range specified on the unit data label. Temperature rises outside the specified range could result in premature heat exchanger failure.

1. Place thermometers in the return and supply air stream as close to the unit as possible. The thermometer on the supply air side must be shielded against direct radiation from the heat exchanger to avoid false readings.
2. Adjust all registers and duct dampers to the desired

position. Run the unit for 10 to 15 minutes before taking any temperature readings. The temperature rise is the difference between the supply and return air temperatures.

NOTE: For typical duct systems, the temperature rise will fall within the range specified on the data label (with the blower speed at the factory recommended setting) shown in Table 11, page 34. If the measured temperature rise falls outside the specified range, it may be necessary to change the blower speed. Lowering the blower speed increases the temperature rise and a higher speed decreases the temperature rise.

The unit is equipped with a belt driven blower and variable pitch motor sheave. The selection of a sheave setting should be based on the desired CFM and the duct system parameters. Refer to the ACCA's Manual Q for a complete description of how to determine these parameters and Manual N for determination of the commercial load requirements. The blower performance data can be found in Tables 4 & 5 (pages 26 & 27).

The integrated control is designed to start the circulating air blower approximately 40 seconds after the gas valve opens and turn the blower motor off approximately 150 seconds after the gas valve is closed.

Verifying Burner Operation

WARNING:

Uninsulated live components are exposed when the louvered control access panel is removed.

1. Remove the louvered control access panel to ensure there is power to the unit.
2. Set the thermostat above room temperature and observe the ignition sequence. The burner flame should carry over immediately between all burners and should extend from each burner without lifting off, curling, or floating. The flames should be blue, without yellow tips.
3. After verifying flame characteristics, set the thermostat below room temperature and verify that the burner flame extinguishes completely.

Verifying Operation of Over-Temperature Limit Control

To verify operation of the over-temperature limit control, make sure the louvered control access panel is in place and that there is power to the unit.

1. Block the return airflow to the unit by installing a close-off plate in place of or upstream of the filter.
2. Set the thermostat above room temperature and verify the unit operates with the correct sequence of operation. See Operating Sequence on page 19.

NOTE: The over-temperature limit control should function to turn off the gas valve within approximately four minutes (exact time depends on the efficiency of the close-off when blocking the return air). The circulating air and combustion

blowers should continue to run when the over-temperature limit control switch opens.

3. Remove the close-off plate immediately after the over-temperature limit control opens. If the unit operates for more than four minutes with no return air, set the thermostat below room temperature, shut off power to the unit, and replace the over-temperature limit control.

NOTE: On some low static/high airflow applications, the Over-Temperature limit control may not function. To ensure the limit is functioning properly, the outlet may also have to be slightly restricted to achieve higher outlet temperatures.

Verifying & Adjusting Firing Rate

The firing rate must be verified for each installation to prevent over-firing of the unit.

CAUTION:

Do not re-drill the burner orifices. If the orifice size must be changed, use only new orifices.

IMPORTANT NOTE: The firing rate must not exceed the rate shown on the unit data label. At altitudes above 2,000 ft., it must not exceed that on the data label less 4% for each 1,000 ft.

Follow the steps below to determine the unit firing rate:

- For installations at 2,000 feet and less, the firing rate is the same as shown on the unit rating label.
 - For installations above 2,000 feet, compute the correct firing rate as shown in the example on page 13.
1. Obtain the gas heating value from the gas supplier (HHV).
 2. Shut off all other gas fired appliances.
 3. Start the unit in heating mode and allow it to run for at least three minutes.
 4. Measure the time (in seconds) required for the gas meter to complete one revolution.
 5. Convert the time per revolution to cubic feet of gas per hour using Table 7 (page 33).
 6. Multiply the gas flow rate in cubic feet per hour by the heating value of the gas in Btu per cubic foot to obtain the firing rate in Btu per hour. See example:

Example:

- Time for 1 revolution of a gas meter with a 1 cubic foot dial = 40 seconds.
- From Table 7, read 90 cubic feet gas per hour.
- Local heating value of the gas (obtained from gas supplier) = 1,040 Btu per cubic foot.
- Input rate = $1,040 \times 90 = 93,600$ Btuh.

7. Adjustments to the firing rate can be made by adjusting the gas manifold pressure. See the High Altitude Deration section (pages 12 - 13) for additional information of firing rate at elevations above 2000 ft.

Manifold Pressure Adjustment

The manifold pressure must be set to the appropriate value for your installation. To adjust the manifold pressure:

1. Obtain the required manifold pressure setting. Refer to either Table 9 for natural gas or Table 10 for LP/propane gas (page 34). **NOTE:** The values listed in the tables are based on sea level values. At higher altitudes, the heating value of gas is lower than the sea level heating value.
2. Remove the regulator cap. Turn the high fire adjusting screw clockwise to increase the pressure or counterclockwise to reduce the pressure.
3. Replace the regulator cap after adjustments are complete.

Refrigerant Charging

WARNING:

If repairs make it necessary for evacuation and charging, it should only be done by qualified, trained personnel thoroughly familiar with this equipment. Some local codes require licensed installation/service personnel to service this type of equipment. Under no circumstances should the owner attempt to install and/or service this equipment.

Failure to comply with this warning could result in property damage, personal injury, or death.

This Single Package Gas Heating / Electric Cooling unit is fully charged at the factory and requires no charging when installed accordingly. Units should be operating with liquid sub-cooling readings between 13° F - 15° F. If measurements indicate a lower or higher sub-cooling reading, refrigerant levels must be adjusted to achieve maximum system performance. The refrigerant charge can be checked and adjusted through the service ports located behind the service panel. Use only gauge lines which have a "Schrader" depression device to actuate the valve.

Refrigerant charging charts for 12.5 and 15 ton units are included in these instructions. To identify proper unit charge operation see Figure 13 (page 28) for 12.5 ton or Figure 14 (page 29) for 15 ton. **NOTE:** Both refrigeration stages must be operating when taking liquid temperature and pressure measurements.

Refrigerant charging must be done by qualified personnel familiar with safe and environmentally responsible refrigerant handling procedures. See Unit Rating Plate for proper amount of refrigerant.

OPERATING SEQUENCE

The operating sequences for the heating, cooling, and fan modes are described below. Refer to the wiring diagrams (Figures 15 & 16, pages 30 & 31).

Cooling Mode

1. On a call for cooling the thermostat closes, applying 24 VAC to **Y1**, **G**, & **Y2** if Stage 2 cooling is calling.
2. **G** applies 24VAC to the main circulating blower circuit.
3. **Y1** & **Y2** apply 24VAC through all safety switches before energizing their respective contactors.
4. When the thermostat is satisfied the contactors are de-energized.
5. The circulating blower motor de-energizes immediately.

Blower Mode

1. On a call for fan operation, the thermostat applies 24 VAC directly to the blower contactor.
2. The circulating blower is energized immediately.

Heating Mode

1. On a call for heat, the thermostat closes, applying 24 VAC to the **W1** terminal (and **W2** terminal if Stage 2 heat is required).
2. The integrated control monitors the safety circuit at all times. If either the roll-out switch or the over-temperature limit controls open, the gas valve will not energize. The main blower continues to operate until the over-temperature limits close, the flame roll-out switch is manually reset, or the thermostat is satisfied.
3. The integrated control checks all safety switches at the beginning of each heating cycle. If closed, the combustion blower performs a 15 second pre-purge.
4. The integrated control will then supply power to the direct spark ignitor and immediately energizes the gas valve. **NOTE:** Burner operation begins in high fire mode with both Stage 1 and Stage 2 gas valve energized, independent of the thermostat call for Stage 2 heat. If after 30 seconds of operation with no call for Stage 2 heat, the integrated control will resume heating operation in low fire mode of operation and Stage 2 gas valve is de-energized.
5. The flame must be proven through the flame sensor in 7 seconds to hold the gas valve open. The integrated control will monitor the gas flame with the flame sensor for the entire time the gas valve is open. If for any reason the gas flame drops out, the gas valve will immediately close. After 30 second purge, the integrated control will try to ignite 14 more times.
6. The main air blower will start and continue to run 40 seconds after the gas valve opens.
7. When the thermostat is satisfied, the integrated control is de-energized. The gas valve and combustion blower de-energize immediately while the main air blower continues to run through the blower off delay of approximately 150 seconds.
8. If the unit fails to prove flame after fifteen ignition attempts, it will go into a soft lockout. The unit will re-

attempt the start-up procedure every hour until the thermostat is satisfied or 24 VAC power is removed from the unit for a minimum period of 5 seconds.

NOTE: For a complete list of heating operation fault codes, see Troubleshooting (page 22) or Figure 15 (pg 30)

UNIT MAINTENANCE

WARNING:

ELECTRICAL SHOCK, FIRE OR EXPLOSION HAZARD

Failure to follow safety warnings exactly could result in serious injury or property damage.

Improper servicing could result in dangerous operation, serious injury, death or property damage.

- **Before servicing, disconnect all electrical power to furnace.**
- **When servicing controls, label all wires prior to disconnecting. Reconnect wires correctly.**
- **Verify proper operation after servicing."**

AVERTISSEMENT:

RISQUE DE CHOC ÉLECTRIQUE, D'INCENDIE OU D'EXPLOSION

Le non-respect des avertissements de sécurité pourrait entraîner un fonctionnement dangereux de l'appareil, des blessures graves, la mort ou des dommages matériels.

Un entreteïn incorrect pourrait entraîner un fonctionnement dangereux de l'appareil, des blessures graves, la mort ou des dommages matériels

- **Couper toute alimentation électrique au générateur d'air chaud avant de prodéder aux travaux d'entreteïn.**
- **Au moment de l'entreteïn des commandes, étiquetez tous les fils avant de les débrancher. S'assurer de les raccorder correctement.**
- **S'assurer que l'appareil fonctionne adéquatement après l'entreteïn.**

NOTE: These maintenance instructions are primarily intended to assist qualified technicians experienced in the proper maintenance and operation of this appliance.

To achieve optimum performance from the air conditioner and minimize equipment failure, it is recommended that annual maintenance be performed on this unit. The ability to properly perform maintenance on this equipment requires certain mechanical skills and tools.

Routine Maintenance

Please consult your dealer for maintenance information and availability of maintenance contracts. At a minimum, routine maintenance should include the following items:

WARNING:

Never operate the unit without filters in place. Dust and lint in the return air can build up on internal components, resulting in loss of efficiency, equipment damage, and possible fire.

- Inspect the condensate drain and outdoor coil at the beginning of each cooling season. Remove any debris. Clean the outdoor coil and louvers as necessary using a mild detergent and water. Rinse thoroughly with water.
 - The blower compartment should be cleaned monthly during the heating and cooling seasons to remove any dirt and lint that may have accumulated in the compartment or on the blower and motor. Buildup of dirt and lint on the blower and motor can create excessive loads on the motor resulting in higher than normal operating temperatures and possible shortened service life.
 - It is recommended that the air filters be inspected and cleaned or replaced every 3 to 4 weeks using filters of like size and kind. Table 1 (page 8) lists the correct filter sizes and quantities for each unit.
 - Inspect the electrical connections for tightness at the beginning of each heating and cooling season.
 - Inspect and clean the screen of the vent cover assembly at the beginning of each heating and cooling season.
-

WARNING:

Holes in the heat exchanger can cause products of combustion to enter the structure. Replace the heat exchanger if leaks are found. Failure to prevent products of combustion from being circulated into the occupied space can create potentially hazardous conditions including carbon monoxide poisoning that could result in personal injury or death.

- Maintain heat exchanger and burners. The unit should operate for many years without excessive scale buildup in the heat exchanger, however, the heat exchanger, the vent system, and the burners should be inspected and cleaned (if required) by a qualified serviceman annually to ensure continued safe operation. Particular attention must be given to identify deterioration from corrosion or other sources.

Motor / Bearing Lubrication Requirements

- The blower assembly in this unit is equipped with three support bearings and one pillow block drive bearing. The support bearings are sealed cartridge units and require no further lubrication. The drive bearing is equipped for future lubrication (field supplied fitting required) since

it is capable of more severe duty. The drive bearing should be checked annually for lubrication requirements based on application and operating conditions or as maintenance experience dictates. Extreme care is important to prevent overfilling or introduction of dirt into the bearing.

- The indoor blower motor is pre-lubricated at the factory and does not require additional lubrication under normal application of this equipment. The motor is equipped with grease fittings if you chose to re-lubricate the bearings based on abnormal conditions or applications. Refer to the motor manufacturers Installation, Operation, and Maintenance Instructions supplied in the owners packet for suggested amounts and type based on the bearing model number listed on the motor nameplate.
- The combustion air blower motor and outdoor fan motors are equipped with pre-lubricated sealed ball bearings. No further oiling is required for the life of this product.

Cleaning the Burners

It is recommended that the burners be inspected and cleaned annually (if required) by a qualified technician to ensure continued safe operation. Particular attention must be given to identify deterioration from corrosion or other sources. If the burners must be cleaned, follow these steps:

1. Shut off the gas supply to the unit either at the meter or at a manual valve in the supply piping.

IMPORTANT NOTE! See gas valve label on the unit or Figure 17 (page 35) for proper gas shutdown instructions.

2. Turn off all power to the unit and set the thermostat to the lowest temperature setting.
 3. Remove the louvered access panel from the unit.
 4. Turn the gas control knob to the "OFF" position.
-

CAUTION:

Label all wires prior to disconnection when servicing controls. Wiring errors can cause improper and dangerous operation.

5. Disconnect the wires from the gas valve, ignitor, flame sensor, and rollout switch.
6. Using two wrenches, separate the ground-joint union in the gas supply piping at the unit.
7. Remove the piping between the gas valve and the ground-joint union.
8. Remove four screws securing the burner assembly to the unit.
9. Carefully remove the burner assembly from the unit. **DO NOT DAMAGE THE IGNITOR WHILE REMOVING THE BURNER ASSEMBLY.**
10. Inspect the burners for accumulated dust or debris. If necessary, carefully clean them with a soft wire brush and/or the nozzle of a vacuum cleaner. **DO NOT DAMAGE THE IGNITOR OR FLAME SENSOR WHILE CLEANING THE BURNER.**
11. Replace all the parts in reverse order from which they were removed.

12. Follow the operating instructions printed on the units gas valve label or Figure 17 (page 35) to return the unit to normal operation. Verify proper operation after servicing.

Cleaning the Heat Exchanger

If the heat exchanger must be cleaned due to soot or scale build up, follow the steps below.

1. Shut off the gas supply to the unit either at the meter or at the manual valve in the gas supply piping.

IMPORTANT NOTE! See gas valve label on the unit or Figure 17 (page 35) for proper gas shutdown instructions.

2. Turn off all power to the unit and set the thermostat to the lowest temperature setting.

CAUTION:

Label all wires prior to disconnection when servicing the unit. Wiring errors can cause improper and dangerous operation.

3. Disconnect the wires from the gas valve, ignitor, flame sensor, and rollout switch.

4. Using two wrenches, separate the ground-joint union in the gas supply piping at the unit.

5. Remove the piping between the gas valve and the ground-joint union.

6. Remove the four screws securing the burner assembly to the unit.

7. Carefully remove the burner assembly from the unit. **DO NOT DAMAGE THE IGNITOR OR FLAME SENSOR WHILE REMOVING THE BURNER ASSEMBLY.**

8. Remove three nuts securing the combustion blower to the collector pan.

9. Remove the combustion blower from the unit.

10. Remove the screws securing the collector pan cover to the unit. Remove the cover plate.

11. Attach a round wire brush to a length of high grade stainless steel cable, such as drain cleanout cable. Attach the other end of the spring cable to a variable speed reversible drill. Slowly insert and rotate the cable into the top portion of the heat exchanger. Operate the drill alternating between forward and reverse, working the cable in and out several times to obtain sufficient cleaning. Repeat this sequence for each heat exchanger tube.

12. Remove all loosened debris from the heat exchanger tubes using high pressure air and vacuum cleaner.

13. Using a light, check the condition of the upper and lower sections of the heat exchanger tube.

14. Inspect the burners and if necessary, clean them carefully with a soft wire brush and/or the nozzle of a vacuum cleaner. **DO NOT DAMAGE THE IGNITOR OR FLAME SENSOR WHILE CLEANING THE BURNER.**

15. Replace all the parts in reverse order from which they were removed. **NOTE:** If screws or other hardware are corroded, replace only with corrosion resistant stainless steel hardware of similar design.

16. Follow the operating instructions printed on the units gas valve label or Figure 17 (page 35) to return the unit to normal operation. Verify proper operation after servicing.

Removal of Unit Top Pan

CAUTION:

Routine maintenance of this equipment does not require removal of the unit top pan. If service is needed which requires removal of the unit top pan, only qualified service personnel should perform this procedure.

If removed, all cleaning and inspections of blower drive, coils, condensate drain pan, etc., should be performed while the top is off. Follow the steps below for top pan removal and replacement:

1. TURN OFF ALL ELECTRICAL POWER TO THE UNIT.
2. Remove all water tight screws securing the top and save for later use.

3. Carefully lift top pan from unit and rest on end. Do not allow top to kink or bend during removal.

4. Upon completion of service, inspect the unit top pan to ensure the insulation has not been damaged and is secured in place. Also inspect the gaskets located on each front corner of the unit top for damage. Replace if necessary to ensure a water tight seal. Secure the top pan with all screws removed in Step 2 to seal out water. Replace any worn or damaged screws "ONLY" with water tight screws or rubber washers.

REPLACEMENT PARTS

Replacement parts are available through all Nordyne distributors. Please have the complete model and serial number of the unit when ordering replacement parts.

Electrical

Capacitors	Pressure Switches
Compressors	Relays
Contactors	Temperature Limit Switches
Gas Valves	Thermostats
Ignition Controls	Time Delay Relays
Ignitors/Flame Sensors	Transformers

Motors

Blower Motor
Fan Motor
Inducer Blower Motor

Components

Blower Assembly	Fan Grille
Burner Manifold	Filter/Driers
Burners/Orifices	Gaskets
Cabinet Panels	Heat Exchanger
Expansion Valves	

COMPONENT FUNCTIONS

The descriptions below are various functional components that affect the operation and shutting down of this unit. Some of these components and their locations are shown in Figure 11 (page 23). If any component on this unit must be replaced, use only Nordyne authorized replacement parts specified in the Replacement Parts List provided online.

Flame Roll-Out Control - The flame roll-out control acts to verify that the burner flame is being drawn into the heat exchanger tubes. If the burner flame is not being drawn into the heat exchanger tubes, the roll-out control will open within several seconds. The combustion blower will continue to operate if the flame roll-out control opens until it is manually reset.

Flame Sensor - The flame sensor acts to prove that flame has carried over from the ignitor to the right-most burner. If no flame is sensed, the unit will be shut down automatically and attempt fourteen additional ignition trials before going into lockout. Recovery from lockout requires a manual reset by either resetting the thermostat or removing 24 volts for a period of 5 seconds. If the thermostat is still calling for heat after one hour the control will automatically reset and attempt to ignite the burner again.

Gas Valve - The gas valve controls the flow of gas to the burners in both low and high fire. When the valve is energized, it automatically opens and regulates the gas pressure to the manifold.

Inducer Motor Pressure Switch - This pressure switch acts to verify that the inducer motor is running. Combustion gases are drawn through the heat exchanger tubes and vented through the vent system.

Indoor Coil Freeze Protection Thermostats - The freeze protection switches are designed to protect the indoor coils from ice and frost accumulations in the event of a loss of airflow by preventing the liquid refrigerant from reaching the compressors. During normal operation, the switches are closed and will open if the coil temperature reaches 28° F (-2° C). The switches will close if the coil temperature reaches 57° F (12° C).

Over-Temperature Limit Control - The over-temperature limit control acts to prevent the air temperature leaving the unit from exceeding the maximum outlet air temperature. If the limit opens, the 24V input signal to the L terminal of the blower time delay relay is lost. The relay switches to Normally Closed (NC) and remains in that position until the limit closes. The over-temperature limit is located beneath the heat exchanger tubes (hairpin end) and can be accessed through the blower/heat exchanger access panel for inspection or service.

Refrigerant Low Pressure Switch - This factory installed switch is designed to protect the compressor from a loss of charge. Under normal conditions, the switch is closed. If the suction pressure falls below 5 psig, then the switch will open and de-energize the outdoor unit. The switch will close again once the suction pressure increases above 20 psig.

Refrigerant High Pressure Switch - This factory installed switch is designed to de-energize the unit when excessive pressure occurs due to abnormal conditions. Under normal conditions, the switch is closed. If the discharge pressure rises above 650 psig, then the switch will open and de-energize the outdoor unit. The switch is a manually reset type and will remain open until the button on top of the switch is depressed.

Upper Secondary Over-Temperature Limit - The upper secondary limit control acts to prevent the unit from operating in case the indoor airflow is disrupted for any reason. (example: Indoor motor failure, broken belt, etc). If the limit opens, the 24V input signal to the L terminal of the blower time delay relay is lost. The relay switches to Normally Closed (NC) and remains in that position until the limit closes. The upper secondary limit is located on the blower deck side panel, opposite end to the motor drive, and can be accessed through the blower/heat exchanger access panel for inspection or service.

TROUBLESHOOTING

If the unit does not operate properly in the cooling mode, check the following:

- The thermostat is operating properly.
- Electrical power to the unit is turned on.
- All safety switches are closed.
- The service doors are in place.
- Transformer circuit breaker is reset.

If the unit does not operate properly in the heating mode, check the following:

- The thermostat is operating properly.
- Electrical power to the unit is turned on.
- All safety switches are closed.
- The gas is on and shut-off valve is open.
- The service doors are in place.
- The flame roll-out control is closed.
- Refer to the diagnostic codes in Table 2 below or the wiring diagram (Figure 15, page 30).
- Transformer circuit breaker is reset.

STATUS LIGHT (Red LED)	FAULT CONDITION
Continuous ON	Operation Normal
2 Flashes	Pressure/centrifugal switch open with inducer on
3 Flashes	Pressure/centrifugal switch closed with inducer off
4 Flashes	Lockout from too many failed ignition tries
5 Flashes	Lockout from too many flame losses
6 Flashes	High temperature switch open
7 Flashes	Rollout switch open
8 Flashes	Flame present with gas off
9 Flashes	Exceeded max limit trips (5) in one call for heat
10 Flashes	Gas valve fault

Table 2. Diagnostic Codes

FIGURES & TABLES

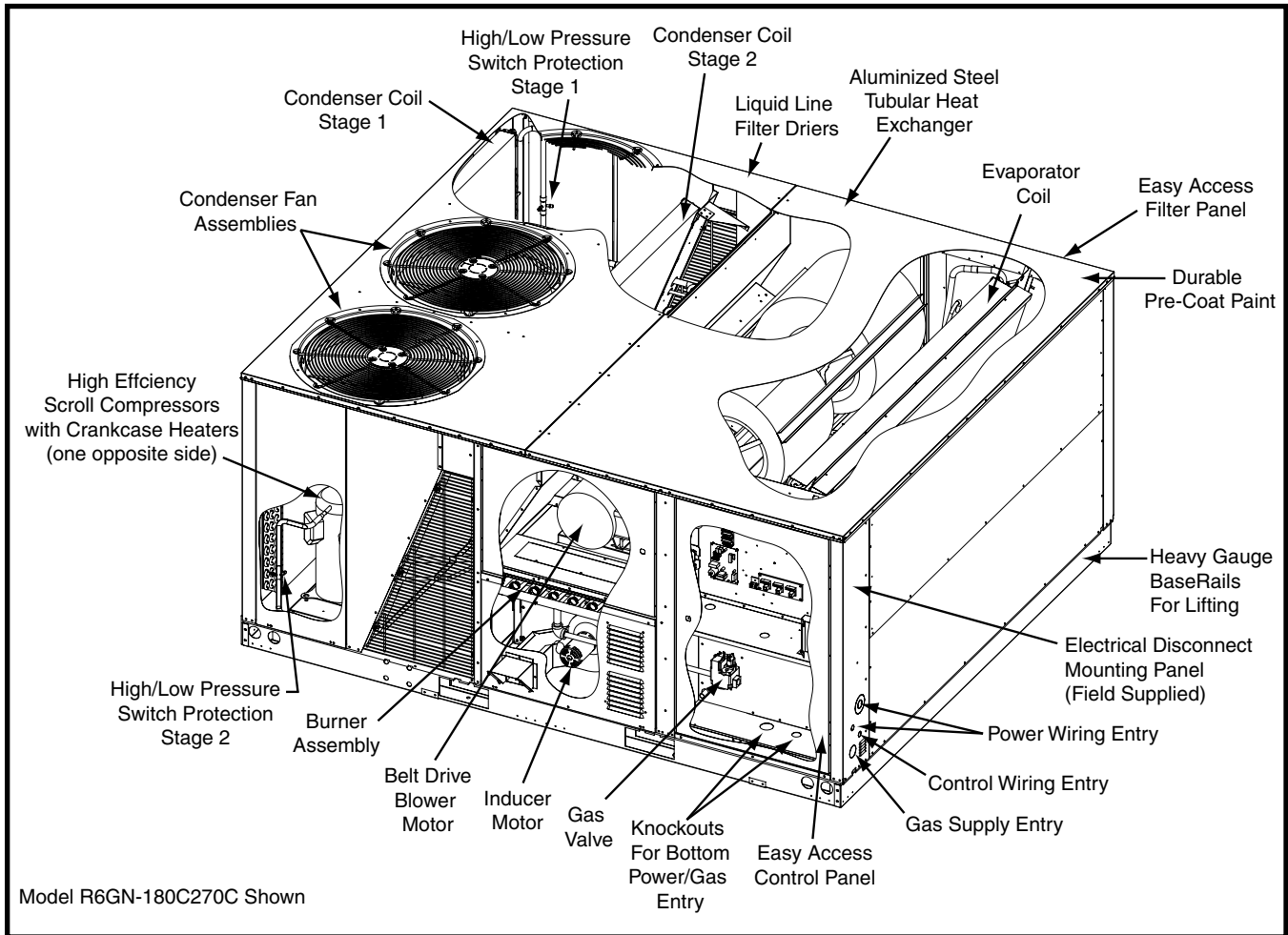

Figure 11. Location of Unit Components

PHYSICAL DIMENSIONS

Dimensions shown in inches (mm)

TOP VIEWS

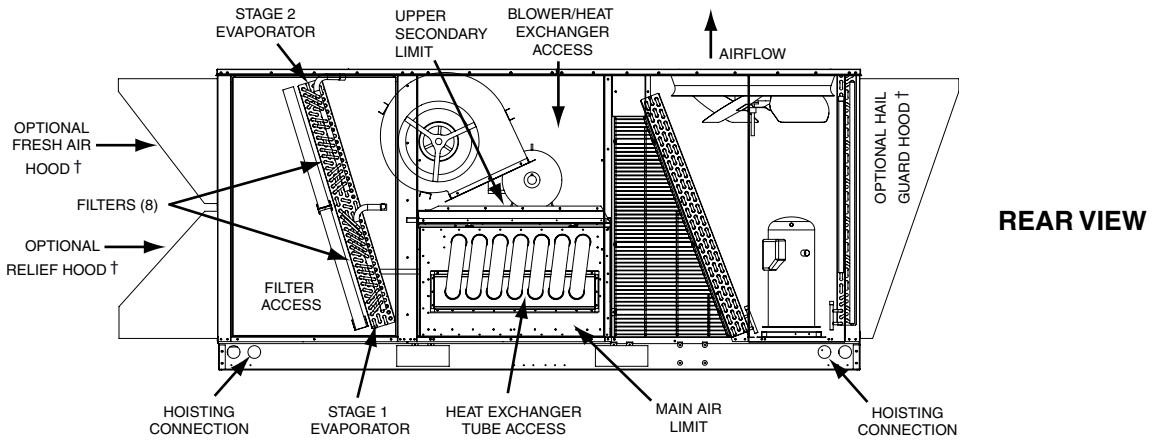
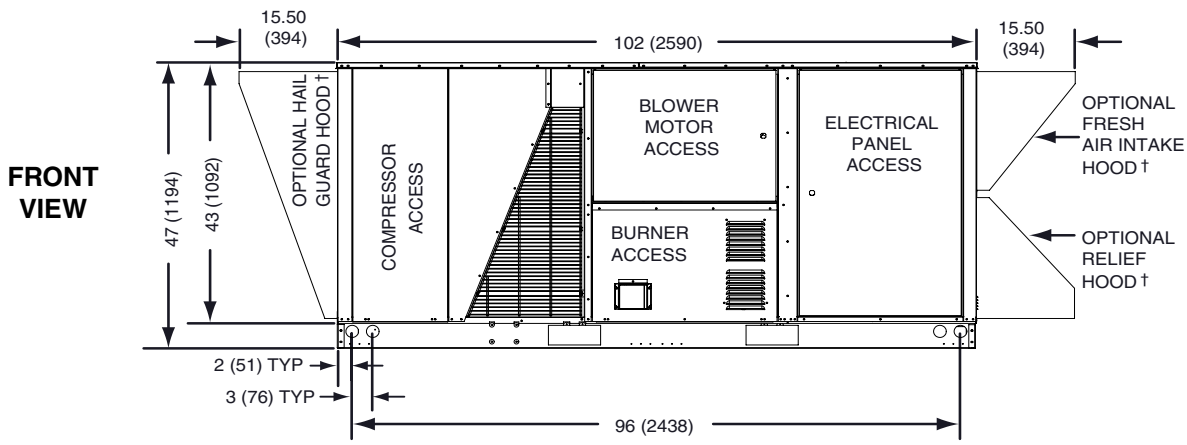
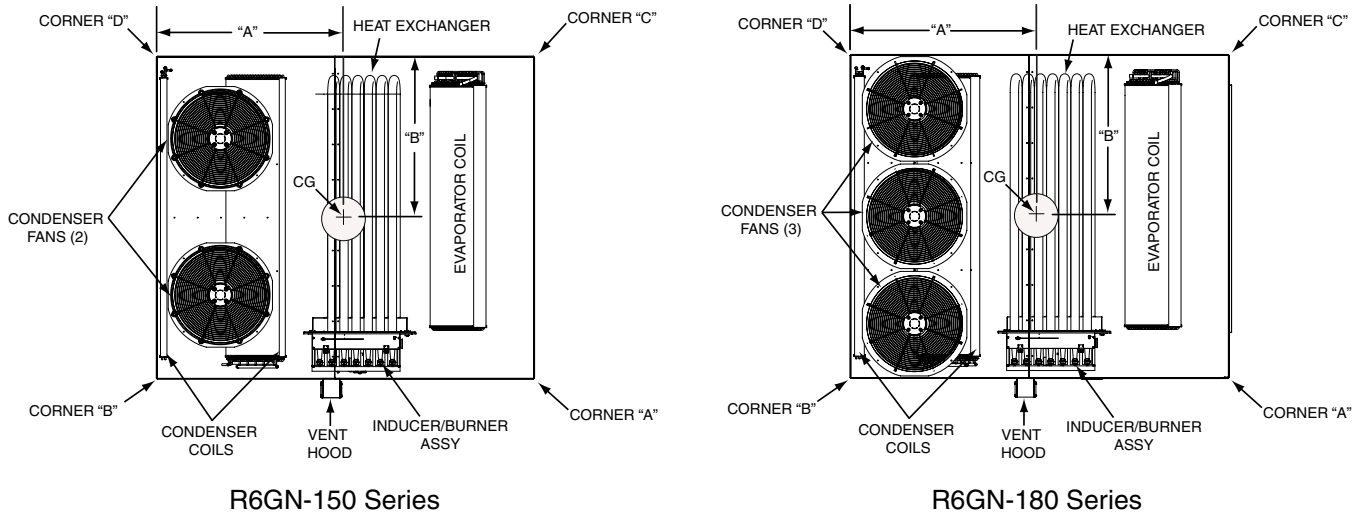
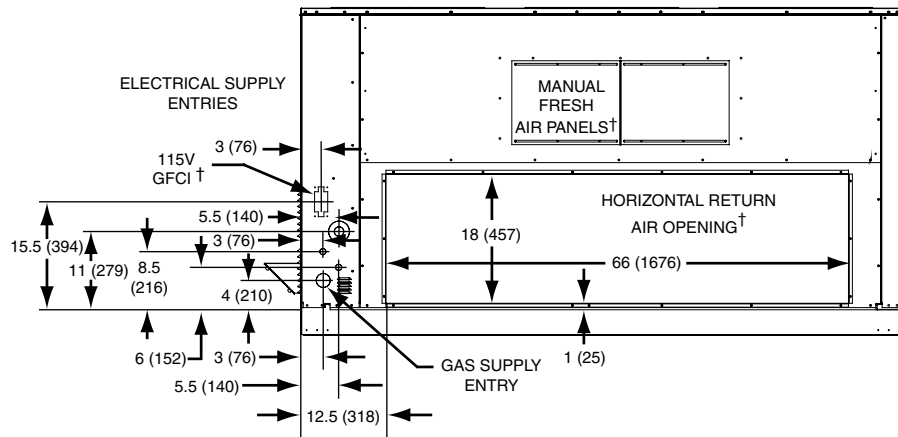
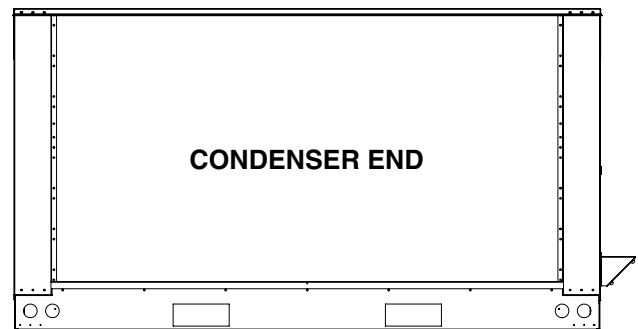
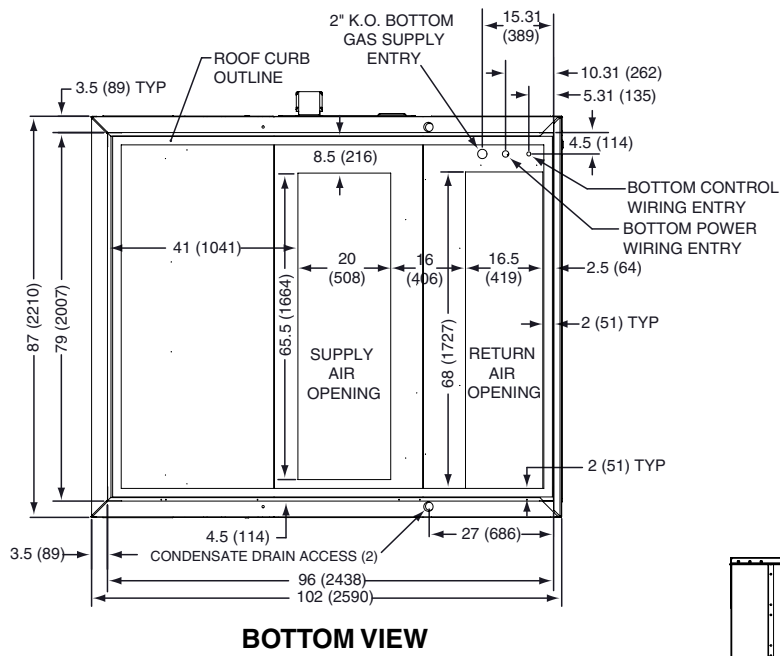

Figure 12. R6GN-150/180 Series



EVAPORATOR / FILTER END

Figure 12 Continued

Unit Model Number	Unit Weight ‡		Shipping Weight		Center of Gravity Inches (mm)		Corner Weights							
					A	B	A		B		C		D	
	Lbs.	Kg.	Lbs.	Kg.			Lbs.	Kg.	Lbs.	Kg.	Lbs.	Kg.	Lbs.	Kg.
R6GN-150	1,730	786	1,944	884	48.75 (1,238)	44.5 (1,130)	430	195	460	209	405	184	435	198
R6GN-180	1,830	832	2,044	929	47.75 (1,213)	44.75 (1,137)	445	202	501	228	415	189	468	213

* Baseraills are not intended to be removed. Information provided is total unit height for horizontal duct applications or height dimension added to selected roof curb height for vertical duct applications.

† Field installed accessories required. ‡ Unit weight without packaging or field installed accessories.

Table 3. Unit Shipping Weights & Center of Gravity

BLOWER PERFORMANCE DATA

3 HP LOW STATIC DRIVE (FACTORY SETTINGS)																					
Motor Sheave Position	External Static Pressures (Inches Water Column)																				
	0.3		0.4		0.5		0.6		0.7		0.8		0.9		1.00		1.10				
	CFM	RPM	Kw	CFM	RPM	Kw	CFM	RPM	Kw	CFM	RPM	Kw	CFM	RPM	Kw	CFM	RPM	Kw	CFM	RPM	Kw
Fully Closed																					
1/2 Turns Open																					
1 Turns Open																					
1.5 Turns Open																					
2 Turns Open																					
2.5 Turns Open																					
3.0 Turns Open																					
3.5 Turns Open																					
4.0 Turns Open*																					
4.5 Turns Open																					
5.0 Turns Open	5300	914	1.95	5000	915	1.84	4650	916	1.73	4300	917	1.62	3700	918	1.43						

5 HP HIGH STATIC DRIVE - OPTIONAL KIT (Refer to Technical Data Sheet for approved accessory kits)																					
Motor Sheave Position	External Static Pressures (Inches Water Column)																				
	1.1		1.2		1.3		1.40		1.50		1.60		1.70		1.80		1.90				
	CFM	RPM	Kw	CFM	RPM	Kw	CFM	RPM	Kw	CFM	RPM	Kw	CFM	RPM	Kw	CFM	RPM	Kw	CFM	RPM	Kw
Fully Closed																					
1/2 Turn Open																					
1 Turn Open																					
1.5 Turns Open																					
2.0 Turns Open																					
2.5 Turns Open																					
3.0 Turns Open																					
3.5 Turns Open																					
4.0 Turns Open*	5350	1188	3.2	5000	1189	3.00	4600	1190	2.75	4200	1191	2.60	3700	1192	2.30						
4.5 Turns Open	5100	1168	2.98	4700	1169	2.75	4250	1170	2.53	3900	1171	2.33									
5.0 Turns Open	4850	1148	2.75	4400	1148	2.50	3900	1149	2.30												

TABLE LEGEND:

* Denotes Factory sheave setting.
 Boldface type indicates factory recommended blower operating range.
 Values include losses for air filters, unit casing, and dry evaporator coil.

Shaded areas not recommended for unit operation.
 See Accessory Performance Data table for additional static pressure information.

Table 4. R6GN-150C Series

5 HP LOW STATIC DRIVE (FACTORY SETTINGS)																		
Motor Sheave Position	External Static Pressures (Inches Water Column)																	
	0.3		0.4		0.5		0.6		0.7		0.8		0.9		1.00		1.10	
	CFM	RPM	Kw	CFM	RPM	Kw	CFM	RPM	Kw	CFM	RPM	Kw	CFM	RPM	Kw	CFM	RPM	Kw
Fully Closed																		
1/2 Turn Open																		
1 Turn Open																		
1.5 Turns Open																		
2.0 Turns Open																		
2.5 Turns Open																		
3.0 Turns Open																		
3.5 Turns Open																		
4.0 Turns Open*																		
4.5 Turns Open																		
5.0 Turns Open	6200	1028	2.84	5900	1029	2.73	5600	1030	2.61	5100	1031	2.33	4600	1032	2.21			

5 HP HIGH STATIC DRIVE - OPTIONAL KIT (Refer to Technical Data Sheet for approved accessory kits)																		
Motor Sheave Position	External Static Pressures (Inches Water Column)																	
	1.1		1.2		1.3		1.40		1.50		1.60		1.7		1.80		1.90	
	CFM	RPM	Kw	CFM	RPM	Kw	CFM	RPM	Kw	CFM	RPM	Kw	CFM	RPM	Kw	CFM	RPM	Kw
Fully Closed																		
1/2 Turn Open																		
1 Turn Open																		
1.5 Turns Open																		
2.0 Turns Open																		
2.5 Turns Open																		
3.0 Turns Open	5800	1228	3.65	5500	1230	3.50	5100	1231	3.30	4800	1232	3.10	4400	1233	2.87			
3.5 Turns Open	5575	1208	3.43	5250	1210	3.25	4850	1211	3.03	4500	1212	1.55						
4.0 Turns Open*	5350	1188	3.2	5000	1189	3.00	4600	1190	2.75									
4.5 Turns Open	5100	1168	2.98	4700	1169	2.75												
5.0 Turns Open	4850	1148	2.75	4400	1148	2.50												

Table 5. R6GN-180C Series

TABLE LEGEND:

* Denotes Factory sheave setting.
 Boldface type indicates factory recommended blower operating range.
 Values include losses for air filters unit casing and dry evaporator coil.
 Shaded areas not recommended for unit operation.
 See Accessory Performance Data table for additional static pressure information.

R6 CHARGING CHARTS

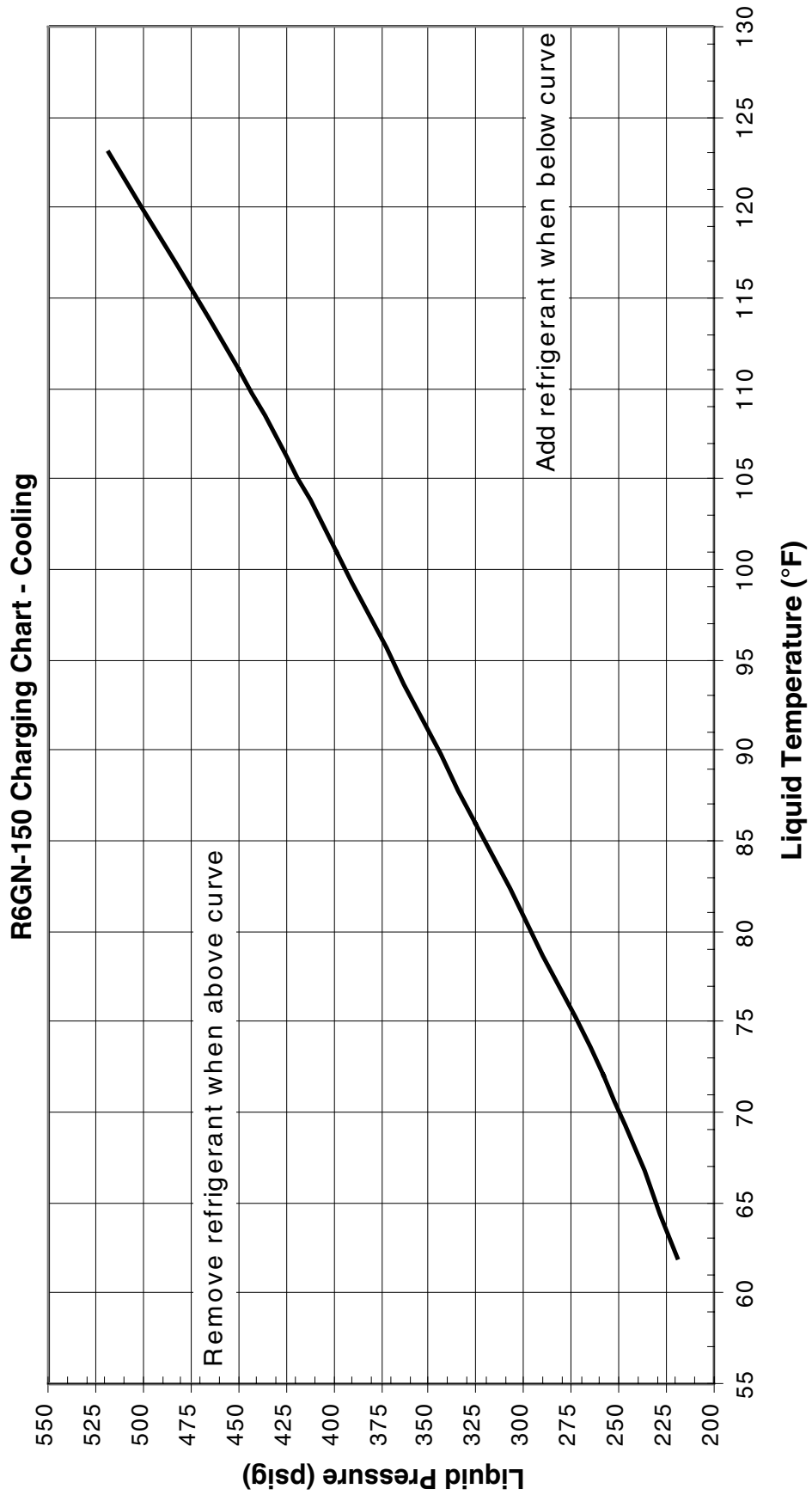

Figure 13. R6GN-150 Series

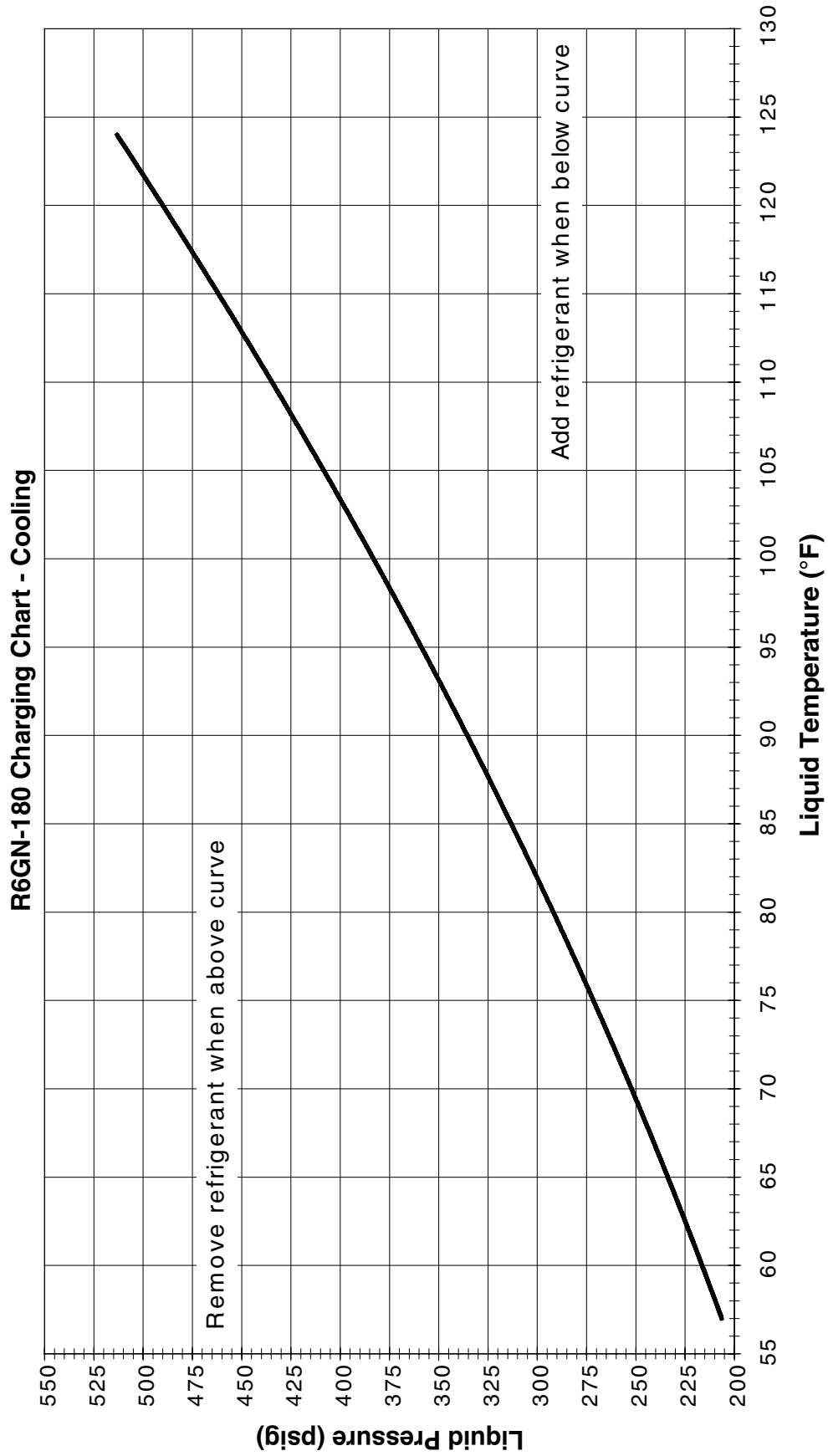

Figure 14. R6GN-180 Series

WIRING DIAGRAM

R6GN-150*/180* Series Convertible Package Gas Heat/Electric Air Conditioner **208-230/460 Volt** **Three Phase 60 Hz.**

NOTES:

1. Disconnect all power before servicing.
2. For supply connections use copper conductors only.
3. If any of the original wire as supplied with the furnace must be replaced, it must be replaced with wiring material having a temperature rating of at least 105C.
4. For supply wire ampacities and overcurrent protection, see unit rating label.
5. Remove white wire from **POWER BLOCK-L3** and connect to autotransformer red wire.
6. For 120C Models only. For 208V operation remove wire from 230V tap and place on 208V tap.

1. Couper le courant avant de faire leretien.
2. Employez uniquement des conducteurs en cuivre.

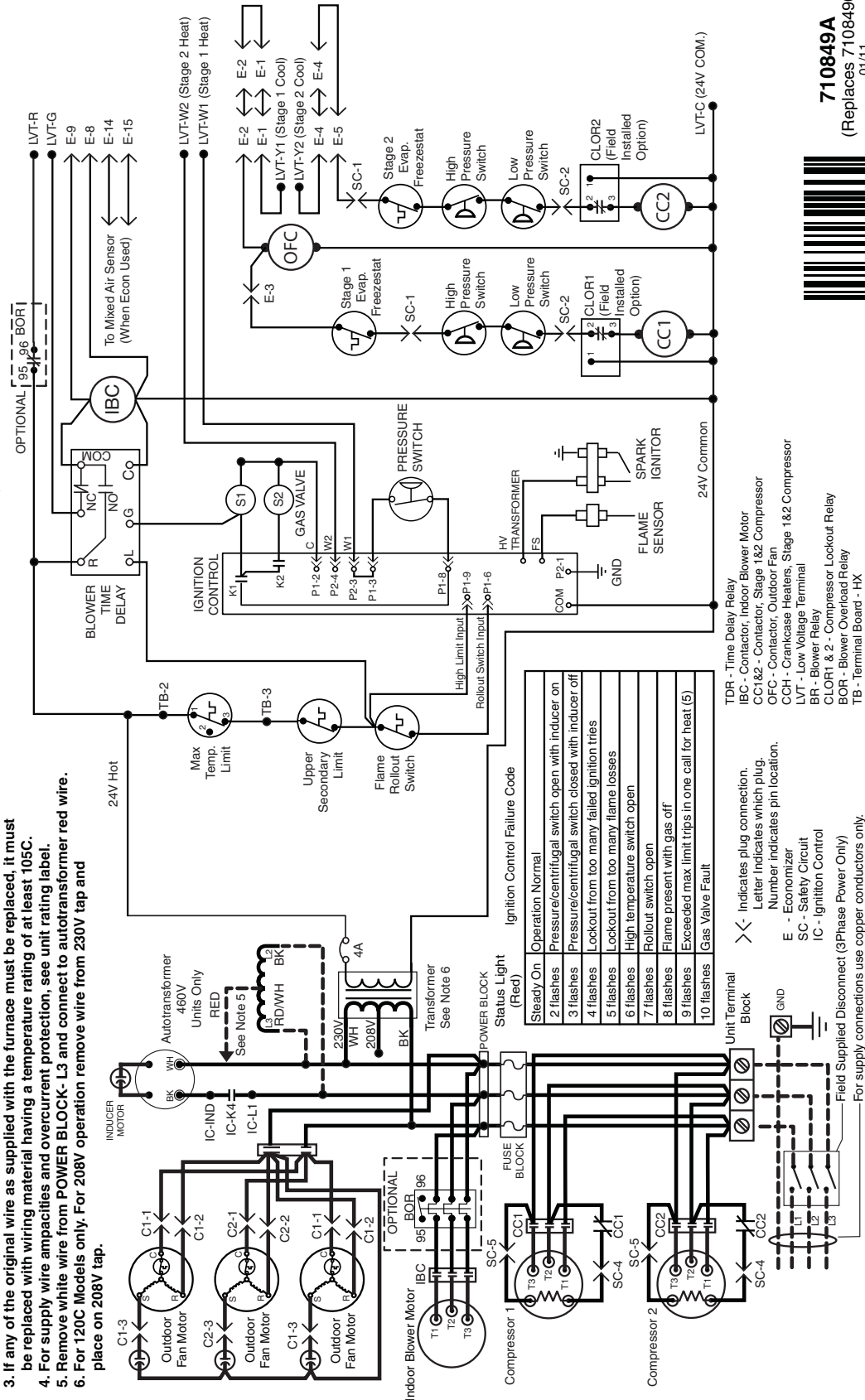

710849A
(Replaces 7108490)
01/11

Figure 15. Ladder Diagram - 150/180 Series

WIRING DIAGRAM

R6GN-150*/180* Series

1. Remove white wire from Power Block terminal (L3) and connect to Autotransformer red wire.
2. Wires attached to normally closed contacts of auxiliary switch.
3. Connect to inboard air sensor when equipped with economizer.

208-230/460 Volt AC

4. For 208V applications, remove wire tap from 240V location on transformer and replace onto 208V tap.
5. Orange wire connects to #2 terminal on compressor lockout and replaced by red #3 wire.
6. Connects to ignition control 24VAC with no overload present.

Three Phase 60 Hz.

1. Couper le courant avant de faire l'entretien.
2. Employez uniquement des conducteurs en cuivre.

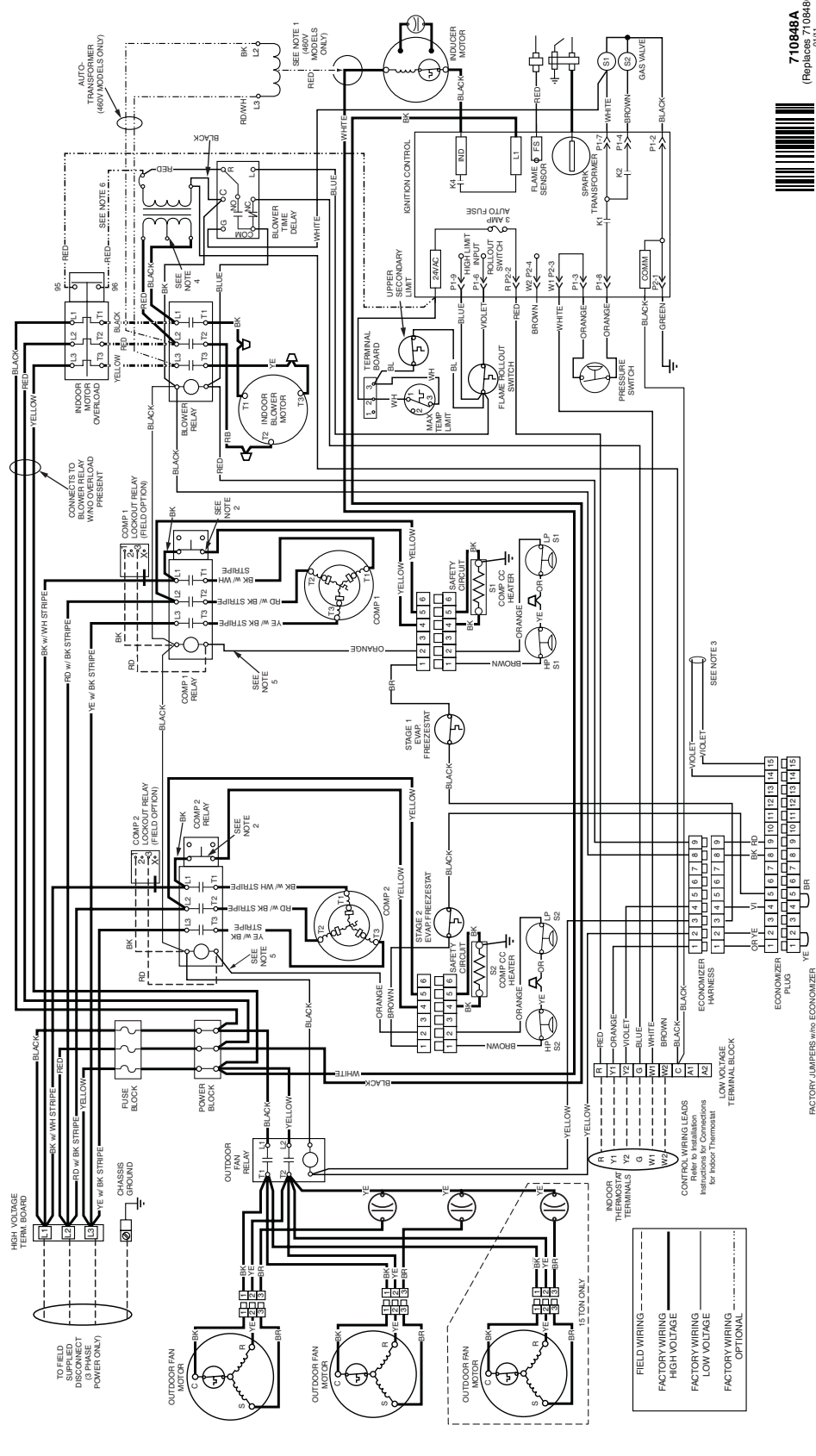

Figure 16. Wiring Diagram - 150 & 180 Series

UNIT MODEL NUMBER	HEATING INPUT (BTU/Hr)		INDUCER MOTOR RLA	NOMINAL ELECTRICAL SUPPLY	VOLTAGE RANGE		COMPRESSORS (2) ea.		OUTDOOR MOTOR		BLOWER DRIVE SYSTEM	INDOOR MOTOR FLA	SINGLE CIRCUIT	
	NAT. GAS	LP			Min.	Max.	RLA	LRA	FLA	Qty.			MINIMUM CIRCUIT AMPACITY	MAX. OVER-CURRENT PROTECTION
R6GN-150C-180C	180,000	153,000	1.4	208-230/3/60	187	253	22.4	149	2.8 ea.	2	LSD	8.7	64.7	80
R6GN-150D-180C	180,000	153,000	1.4	460/3/60	414	506	10.6	75	1.4 ea.	2	HSD	13.8	69.8	90
R6GN-150C-270C	270,000	230,000	1.4	208-230/3/60	187	253	22.4	149	2.8 ea.	2	LSD	8.7	64.7	80
R6GN-150D-270C	270,000	230,000	1.4	460/3/60	414	506	10.6	75	1.4 ea.	2	HSD	13.8	69.8	90
R6GN-180C-270C	270,000	230,000	1.4	208-230/3/60	187	253	25.0	164	2.3 ea.	3	LSD	13.8	77.0	100
R6GN-180D-270C	270,000	230,000	1.4	460/3/60	414	506	12.2	100	1.2 ea.	3	HSD	13.8	77.0	100
R6GN-180C-315C	315,000	268,000	1.4	208-230/3/60	187	253	25.0	164	2.3 ea.	3	LSD	13.8	77.0	100
R6GN-180D-315C	315,000	268,000	1.4	460/3/60	414	506	12.2	100	1.2 ea.	3	HSD	13.8	77.0	100

NOTE: FLA = Full Load Amps; LRA = Locked Rotor Amps; RLA = Rated Load Amps; LSD = Low Static Blower Drive; HSD = High Static Blower Drive

Table 6. Electrical Data

GAS INFORMATION

GAS FLOW RATES				GAS FLOW RATES			
TIME FOR ONE REVOLUTION (SECONDS)	CUBIC FEET PER REVOLUTION OF GAS METER			TIME FOR ONE REVOLUTION (SECONDS)	CUBIC FEET PER REVOLUTION OF GAS METER		
	1	5	10		1	5	10
10	360	1,800	3,600	66	55	273	545
12	300	1,500	3,000	68	53	265	529
14	257	1,286	2,571	70	51	257	514
16	225	1,125	2,250	72	50	250	500
18	200	1,000	2,000	74	49	243	486
20	180	900	1,800	76	47	237	474
22	164	818	1,636	78	46	231	462
24	150	750	1,500	80	45	225	450
26	138	692	1,385	82	44	220	439
28	129	643	1,286	84	43	214	429
30	120	600	1,200	86	42	209	419
32	113	563	1,125	88	41	205	409
34	106	529	1,059	90	40	200	400
36	100	500	1,000	92	39	196	391
38	95	474	947	94	38	191	383
40	90	450	900	96	38	188	375
42	86	429	857	98	37	184	367
44	82	409	818	100	36	180	360
46	78	391	783	102	35	176	353
48	75	375	750	104	35	173	346
50	72	360	720	106	34	170	340
52	69	346	692	108	33	167	333
54	67	333	667	110	33	164	327
56	64	321	643	112	32	161	321
58	62	310	621	114	32	158	316
60	60	300	600	116	31	155	310
62	58	290	581	118	31	153	305
64	56	281	563	120	30	150	300

Table 7. Gas Flow Rates

GAS PIPE CAPACITIES								
Nominal Pipe Diameter (IN.)	Length of Pipe Run (Feet)							
	10	20	30	40	50	60	70	80
1/2	130	90	75	65	55	50	45	40
3/4	280	190	150	130	115	105	95	90
1	520	350	285	245	215	195	180	170
1 1/4	1,050	730	590	500	440	400	370	350
1 1/2	1,600	1,100	890	760	670	610		

Cubic Feet Per Hour Required = $\frac{\text{Input To Furnace (Btu/hr)}}{\text{Heating Value of Gas (Btu/Cu. Ft.)}}$

NOTE: The cubic feet per hour listed in the table above must be greater than the cubic feet per hour of gas flow required by the furnace. To determine the cubic feet per hour of gas flow required by the furnace, divide the input rate of the furnace by the heating value (from gas supplier) of the gas.

**Table 8. Capacity of Black Iron Gas Pipe (cu. ft. per hour)
for Natural Gas w/ Specific Gravity = 0.60**

NATURAL GAS								
UNIT MODEL NUMBER	GAS TYPE	HEATING INPUT (BTU/HR.)	NUMBER OF BURNERS	0 to 2,000 FT	2,000 to 4,000 FT	4,000 to 6,000 FT	6,000 to 7,000 FT	ELEVATION
				661118	918839	918840	918841	NORDYNE PART NO.
R6GN-150(C,D)-180C	NAT.	180,000	4	1/8"	31	33	34	ORIFICE SIZE
R6GN-150(C,D)-270C	NAT.	270,000	6	1/8"	31	33	34	
R6GN-180(C,D)-315C	NAT.	315,000	7	1/8"	31	33	34	

Table 9. Orifice or Drill Size for Natural Gas

PROPANE (LP) GAS								
UNIT MODEL NUMBER	GAS TYPE	HEATING INPUT (BTU/HR.)	NUMBER OF BURNERS	0 to 2,000 FT	2,000 to 4,000 FT	4,000 to 6,000 FT	6,000 to 7,000 FT	ELEVATION
				918798	918798	918798	918798	NORDYNE PART NO.
R6GN-150(C,D)-180C	LP	153,000	4	49	50	51	51	ORIFICE SIZE
R6GN-180(C,D)-270C	LP	230,000	6	49	50	51	51	
R6GN-180(C,D)-315C	LP	268,000	7	49	50	51	51	

Table 10. Orifice or Drill Size for Propane (LP) Gas

UNIT MODEL NUMBER	GAS TYPE	HEATING INPUT	HEATING OUTPUT	HEATING RISE RANGE (° F)	CFM RANGE (RISE °F)*				
					4400	4600	4800	5000	5200
R6GN-150(C,D)-180C	LP	153,000	122,000	20 - 50	26	25	24	23	22
	NAT.	180,000	144,000	20 - 50	30	29	28	27	26
R6GN-150(C,D)-270C	LP	230,000	184,000	30 - 60	39	37	35	34	33
	NAT.	270,000	216,000	30 - 60	45	43	42	40	38

UNIT MODEL NUMBER	GAS TYPE	HEATING INPUT	HEATING OUTPUT	HEATING RISE RANGE (° F)	CFM RANGE (RISE °F)*				
					5200	5400	5600	5800	6000
R6GN-180(C,D)-270C	LP	230,000	184,000	30 - 60	33	32	30	29	28
	NAT.	270,000	216,000	30 - 60	38	37	36	34	33
R6GN-180(C,D)-315C	LP	268,000	214,000	30 - 60	38	37	35	34	33
	NAT.	315,000	252,000	30 - 60	45	43	42	40	39

NOTE: * Rise (° F) = Heating Output ÷ CFM ÷ 1.08

Table 11. Heating Rise / Range

FOR YOUR SAFETY READ BEFORE OPERATING

WARNING: If you do not follow these instructions exactly, a fire or explosion may result causing property damage, personal injury, or loss of life.

- A. This appliance does not have a pilot. It is equipped with an ignition device which automatically lights the burner. Do not try to light the burner by hand.
- B. BEFORE OPERATING smell all around the appliance area for gas. Be sure to smell next to the floor because some gas is heavier than air and will settle on the floor.
- WHAT TO DO IF YOU SMELL GAS**
- Do not try to light any appliance.
 - Do not touch any electrical switch; do not use any phone in your building.
 - Immediately call your gas supplier from a neighbor's phone. Follow the gas supplier's instructions.
 - If you cannot reach your gas supplier, call the fire department.
- C. Use only your hand to push in or turn the gas control knob. Never use tools. If the knob will not push in or move by hand, do not try to repair it, call a qualified service technician. Force or attempted repair may result in a fire or explosion.
- D. Do not use this appliance if any part has been under water. Immediately call a qualified service technician to inspect the appliance and to replace any part of the control system and any gas control which has been under water.

POUR VOTRE SÉCURITÉ. À LIRE AVANT L'EMPLOI

ATTENTION! L'observation de ces instructions peut entraîner un incendie ou une explosion pouvant causer des dommages à votre propriété à votre personne, ou la mort.

- A. Cet appareil ménager n'a pas de veilleuse. Il est doté d'un système d'allumage automatique. Ne pas essayer d'allumer le brûleur manuellement.
- B. AVANT L'USAGE. Attention à une possible odeur de gaz surtout au niveau du plancher où les gaz les plus lourds ont la tendance de se concentrer.
- EN CAS D'ODEUR DE GAZ.**
- Ne mettre en marche aucun appareil électrique.
 - Ne toucher à aucun commutateur électrique, ne pas employer le téléphone.
 - Quitter le bâtiment immédiatement et avvertir la compagnie du gaz en utilisant le téléphone d'un voisin.
 - A défaut de la compagnie du gaz, avvertir le service des pompiers.
- C. Enfoncer ou faire tourner le robinet à gaz à la main seulement. Ne jamais utiliser d'outils. S'il n'est pas possible de faire tourner ou d'enfoncer le robinet à la main, ne pas essayer de le réparer. Faire appel à un spécialiste. Forcer ou tenter de réparer le robinet pourrait être à l'origine d'une explosion ou d'un incendie.
- D. Il est déconseillé d'utiliser cet appareil en contact prolongé avec l'eau. Faire inspecter ou remplacer toute commande par un technicien qualifié si un des systèmes de contrôle du gaz s'est trouvé sous l'eau.

OPERATING INSTRUCTIONS

1. **STOP!** Read the safety information above on this label.
2. Set the thermostat to the lowest setting.
3. Turn off all electrical power to the appliance.
4. The appliance's ignition device automatically lights the burner. Do not try to light burner by hand.
5. Remove the control access door/panel (upper door if two-door model).
6. Move the gas control switch to the "OFF" position. (See Figure 1)
7. Wait five (5) minutes to clear out any gas. Then smell for gas, including near the floor. If you smell gas, STOP! Follow "B" in above information. If you don't smell gas, go to the next step.
8. Move the gas control switch to the "ON" position. (See Figure 1)
9. Replace the control access door/panel (upper door if two-door model).
10. Turn on all electrical power to the appliance.
11. Turn the thermostat to a desired setting.
12. If the appliance will not operate, follow the instructions "To Turn Off Gas To Appliance" and call your service technician or gas supplier.

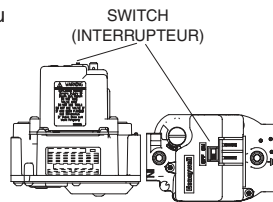

Figure 1

MODE D'EMPLOI

1. **ATTENTION!** Lire d'abord la liste des mesures de sécurité ci-dessus.
2. Mettre le thermostat à la position minimale.
3. Couper le courant électrique qui mène à l'appareil.
4. Cet appareil ménager étant doté d'un système d'allumage automatique, ne pas essayer d'allumer le brûleur manuellement.
5. Retirer le panneau/volet d'accès de commande (panneau supérieur s'il s'agit d'un modèle à deux panneaux).
6. Réglez l'interrupteur de commande du gaz à la position "OFF". (voir Figure 1).
7. Attendre cinq (5) minutes pour s'assurer de la dissipation du gaz. En cas d'odeur, ARRÊTER LE PROCÉDÉ. Suivre les instructions ci-dessus (Section B). En l'absence de toute odeur de gaz, avancer à l'étape suivante.
8. Réglez l'interrupteur de commande du gaz à la position "ON". (voir Figure 1).
9. Remettre le panneau/volet d'accès de commande en place (panneau supérieur s'il s'agit d'un modèle à deux panneaux).
10. Rebrancher l'appareil sur le réseau électrique.
11. Ajuster le thermostat à la position désirée.
12. Si l'appareil ne fonctionne pas, suivre les "Directives d'arrêt" cidessous et appeler le technicien de service.

TO TURN OFF GAS TO APPLIANCE

1. Set the thermostat to the lowest setting.
2. Turn off all electrical power to the appliance if service is to be performed.
3. Remove the control access door/panel (upper door if two-door model).
4. Move the gas control switch to the "OFF" position. Do not use force. (See Figure 1)
5. Replace the control access door/panel (upper door if two-door model).

DIRECTIVES D'ARRÊT

1. Mettre le thermostat à la position minimale.
2. Débrancher l'appareil en prévision de la réparation.
3. Retirer le panneau/volet d'accès de commande (panneau supérieur s'il s'agit d'un modèle à deux panneaux).
4. Réglez l'interrupteur de commande du gaz à la position "OFF". Ne forcez pas. (voir Figure 1).
5. Remettre le panneau/volet d'accès de commande en place (panneau supérieur s'il s'agit d'un modèle à deux panneaux).

710674-0 (Replaces 7104030) (03/07)

Figure 17. Gas Valve Label

INSTALLATION / PERFORMANCE CHECK LIST

INSTALLATION ADDRESS:		
CITY _____	STATE _____	
UNIT MODEL # _____		
UNIT SERIAL # _____		
Unit Installed Minimum clearances per Figure 1 (page 5)?	YES	NO
INSTALLER NAME:		
CITY _____	STATE _____	
Has the owner's information been reviewed with the customer?	YES	NO
Has the Literature Package been left with the unit?	YES	NO

ELECTRICAL SYSTEM		
Electrical connections tight?	YES	NO
Line voltage polarity correct?	YES	NO
Rated Voltage: _____ VOLTS		
L1-L2 Volts: _____ VOLTS		
L1-L3 Volts: _____ VOLTS		
L2-L3 Volts: _____ VOLTS		
Avg. Volts: _____ VOLTS		
Max. Deviation of Voltage From Avg Volts _____ VOLTS		
% Volt Imbalance: _____ VOLTS		
Blower Motor HP: _____ Sheave Setting _____ # Turns		
Has the thermostat been calibrated?	YES	NO
Is the thermostat level?	YES	NO
Is the heat anticipator setting correct?	YES	NO

GAS SYSTEM		
Gas Type: (circle one)	Natural Gas	Propane
Gas pipe connections leak-tested?	YES	NO
Gas Line Pressure: _____ (in - W.C.)		
Is there adequate fresh air supply for combustion & ventilation?	YES	NO
Installation Altitude: _____ (FT.)		
Deration Percentage: _____ (%)		
Furnace Input: _____ (Btuh)		
Supply Air Temperature: _____ (° F)		
Return Air Temperature: _____ (° F)		
Temperature Rise: _____ (° F)		
During Furnace Operation:		
Low fire manifold pressure: _____ (in - W.C.)		
High fire manifold pressure: _____ (in - W.C.)		

REFRIGERATION SYSTEM		
Was unit given 24 hr warm up period for crankcase heaters?	YES	NO
Did reversing valve energize?	YES	NO
Stage-1 Liquid Pressure (high side) _____		
Stage-1 Suction Pressure (low side) _____		
Stage-2 Liquid Pressure (high side) _____		
Stage-2 Suction Pressure (low side) _____		

VENTING SYSTEM		
Is the vent hood installed?	YES	NO
Is vent hood free from restrictions	YES	NO
Filter(s) secured in place?	YES	NO
Filter(s) clean?	YES	NO



* AHRI commercial furnace certification listing applies only to 3 phase units having an input rate 225,000 Btu/hr or greater

NORDYNE
COMPLETE COMFORT. GENUINE VALUE.



Specifications & illustrations subject to change without notice or incurring obligations.
O' Fallon, MO | Printed in U.S.A. (02/11)

708956B (Replaces 708956A)