

Bottom Power Entry Kit

Installation Instructions

R6GP Model Series Accessory Light Commercial Packaged Gas Electric Units

This kit is designed to allow passage of high and low voltage wiring connections through the unit bottom pan on R6GP Series units.

**WARNING:**

This kit is to be installed by a qualified service technician in accordance with these instructions and all codes having jurisdiction. Failure to follow these instructions could result in serious injury, property damage, or death.

**WARNING:**

All electrical wiring must comply with the latest edition of the National Electrical Code ANSI/NFPA 70.

These instructions are primarily intended to assist qualified individuals experienced in the proper installation of this appliance. Some local codes require licensed installation/service personnel for this type of equipment.

This Kit Includes:

- 1) Parts kit:
 - a. 3/4" diameter, FMC straight connectors (2 ea.)
 - b. 3/4" diameter, insulator sleeve (2 ea.)
 - c. 3/4" diameter, insulator bushing (2 ea.)
 - d. 3/4" diameter, FMC (48" long)
 - e. 1-1/4" diameter, FMC straight connectors (2 ea.)
 - f. 1-1/4" diameter, insulator sleeve (2 ea.)
 - g. 1-1/4" diameter, insulator bushing
 - h. 1-1/4" diameter, FMC (24" long)
- 2) Bottom Power entry electrical box assembly
- 3) Bottom Power entry electrical box cover plate
- 4) 7/8" Diameter, plastic hole plug
- 5) 7/8" Diameter, plastic star bushing
- 6) 1/2" long #10 Screws (x ea.)
- 7) Zip-ties
- 8) Kit Instructions

Field Supplied Items list:

- 1) Thread Sealant
- 2) Unit Disconnect
- 3) All conduit necessary for connections external to the unit

Prior to beginning Installation, ensure the follow conditions are met:

- 1) Read and understand the instructions for all accessory kits to be installed with the unit and the unit installation instructions
- 2) Unit is installed on roof-curb
- 3) No electrical power is connected to unit
- 4) Verify that input power supply is correct, verify with unit rating label
- 5) Branch circuit protection to be used for unit is sized in accordance with all applicable codes and unit requirements
- 6) Perform all electrical set-up inspections called for in unit Installation instructions
- 7) Verify kit contents to inventory list above
- 8) Verify all field supplied items are on-hand for installation

Installation Instructions:

1. Remove unit control panel, blower access door and field-wiring, electrical element access door are removed. (Refer to unit installation instructions, Physical data pages)
2. If applicable, it is recommended to install any other accessory kits in the unit prior to completing this kits installation.



Figure 1.

3. Remove the bottom power kit base-plate installed in the unit, under the units blower, by removing the four attaching screws. (see Figure 1, save screws)
 - The base-plate is provided with four – 7/8” knock-outs for both low & high voltage wiring entry to the unit. The two – left side knock-outs are for the low voltage compartment and the two – right side knock-outs are for the high voltage entry(s). If a larger entry hole is required, use a sheet metal hole punch or other applicable method to produce the proper hole diameter for the strain-relief or conduit connection to be utilized. (See Figure 16)
 - Note: Bottom power base-plate is not designed to support the weight of long conduit or wire runs or installations using large gage wires. Always ensure the conduits and wiring coming into the unit is properly supported from the building structure and not from the unit.

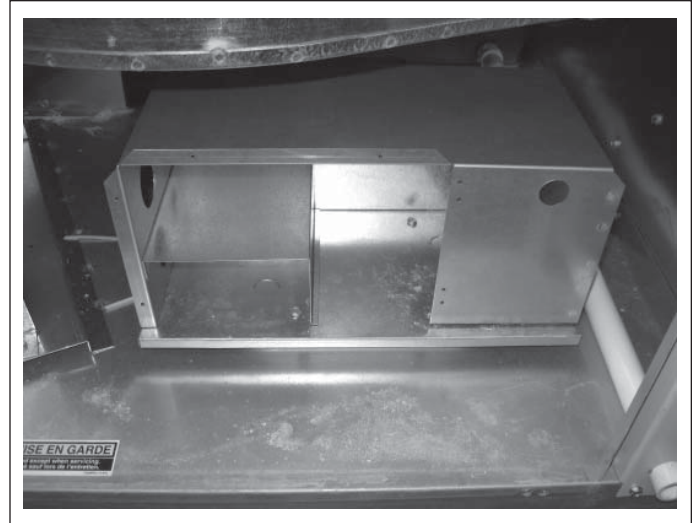

Figure 2.

4. Replace bottom power base-plate with wiring conduit or strain-relief and re-attach with the same screws.
5. Install bottom power entry box on to base-plate and attach with four – 1/2” long #10 screws (provided) using a 5/16” nutdriver. (See Figure 2)

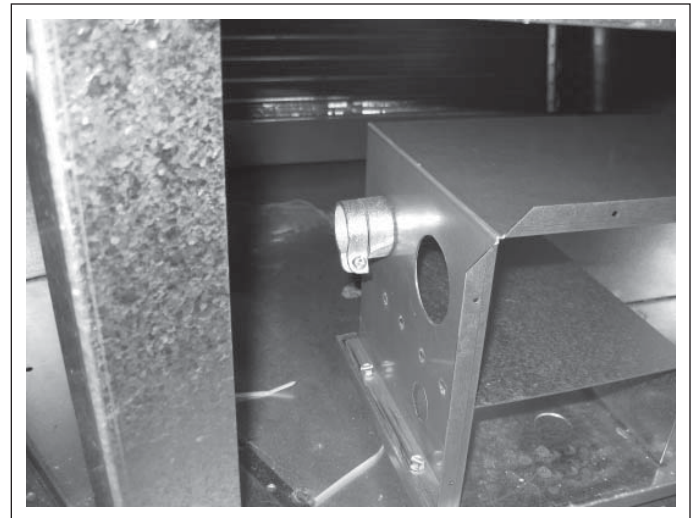

Figure 3.

6. Install one of the 3/4” diameter FMC connectors to the top, rear, conduit opening in the bottom power entry box. Angle the connectors tightening screw up towards blower to allow access when next connector is installed in front of it. (see Figure 3)



Figure 4.

7. On the left side of the unit control panel, behind the low-voltage connection box, remove the 1" diameter Heyco bushing from the base of the control panel and install the remaining 3/4" diameter FMC connector.
8. Install the two insulator sleeves in the ends of the 3/4" diameter flexible metal conduit and then install the conduit fully into the connectors and secure it in place.

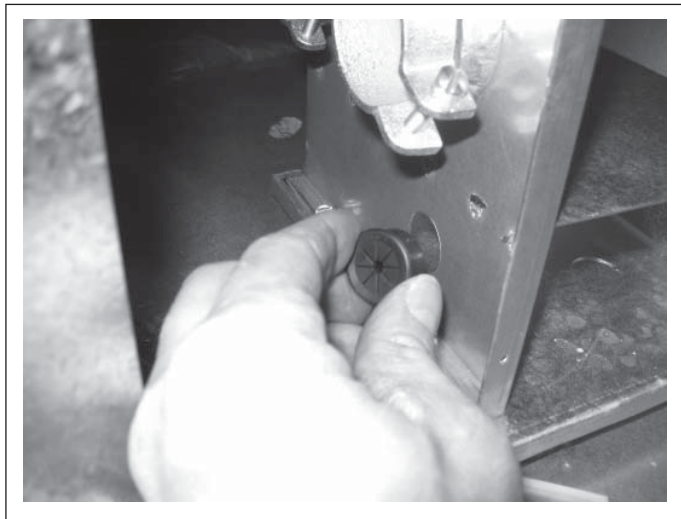

Figure 5.

9. Install the 7/8" diameter star bushing into the bottom hole on the bottom power entry box and one of the 1-1/4" diameter FMC connectors in the remaining (top, front) hole of the bottom power entry box.



Figure 6.

10. On the base of the Blower compartment/Condenser section external divider panel, remove the plastic button plug and open up the slit in the insulation.



Figure 7.

11. Install the remaining 1-1/4" diameter FMC connector.
12. Insert the two 1-1/4" insulator sleeves into the ends of the 1-1/4" flexible metal conduit and install the conduit into the two connectors. Secure the conduit in place.

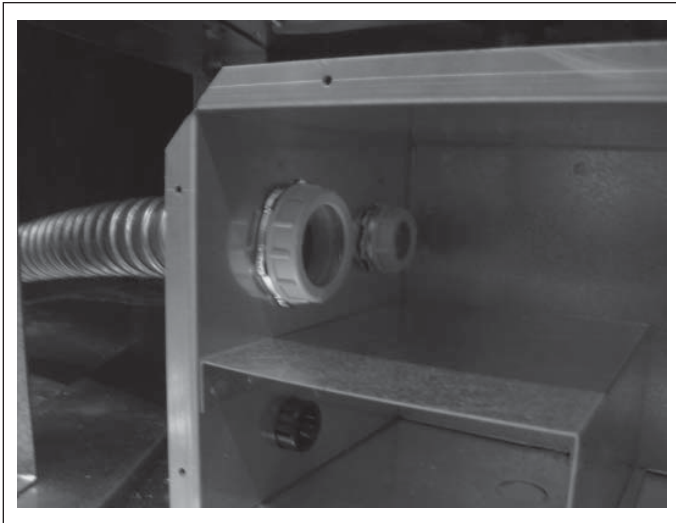

Figure 8.

13. Install the threaded insulator bushings onto both of the high voltage wiring conduits in the bottom power entry box and in the unit control panel.

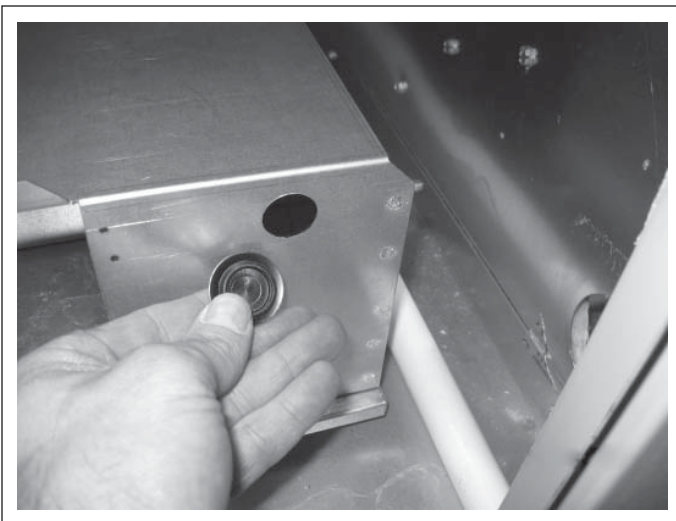

Figure 9.

14. For Installations of equipment that do not include the factory installed – convenience outlet option: Install the provided, 7/8" plastic, button plug into the small hole on the front face of the bottom power entry box. (see Figure 12) On units that are equipped with the convenience outlet, install the strain-relief device instead of the button plug. (Field supplied: two-screw or other applicable device.) For more information, refer to the factory installed outlet instructions.

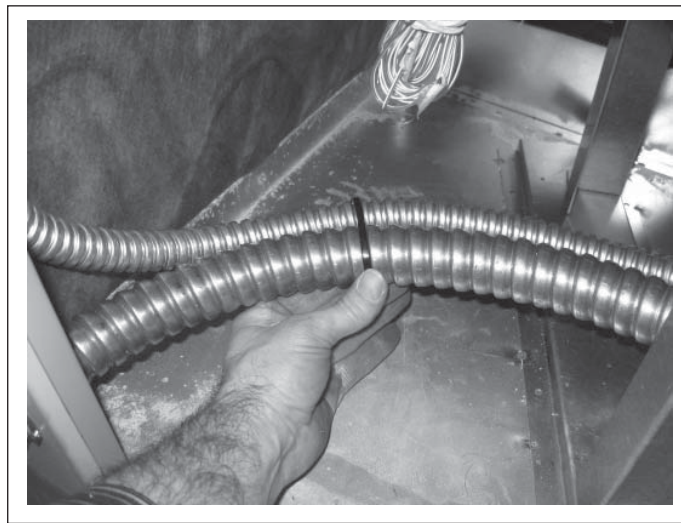

Figure 10.

15. Holding the 3/4" diameter conduit tight to the corner of the compartment, use one of the supplied zip-ties to secure the two FMC conduits together.
16. Install unit disconnect and conduit to connect disconnect to the unit's heat exchanger end panel. Refer to the Unit's Installation Instructions, Physical Data Pages, for the recommended disconnect mounting location and connection points. (See Figures 14 & 18)
17. Bring the high voltage, unit power supply wiring (and if applicable, 110V convenience outlet supply wiring) into the right side of the bottom power entry box for connections. Route wires from the bottom power entry box, to the unit disconnect and then to the unit HV inputs. Refer to the unit and other installed accessory kits installation instructions for details. (See Figure 18)
18. Bring the Low voltage, unit control wiring into the bottom power entry box, under the low voltage divider. Make connections in the bottom power entry box, low voltage area – or – route wires/cable through the star bushings installed in step 9 to the unit low voltage connections through the base of the unit control panel. (See Figure 18)
19. Using the remaining zip-ties, secure the FMC conduits and low-voltage cable together. Ensure that the wiring is secure and will not interfere with the blower operation. Secure the bottom power box, cover plate in place with the supplied screws.

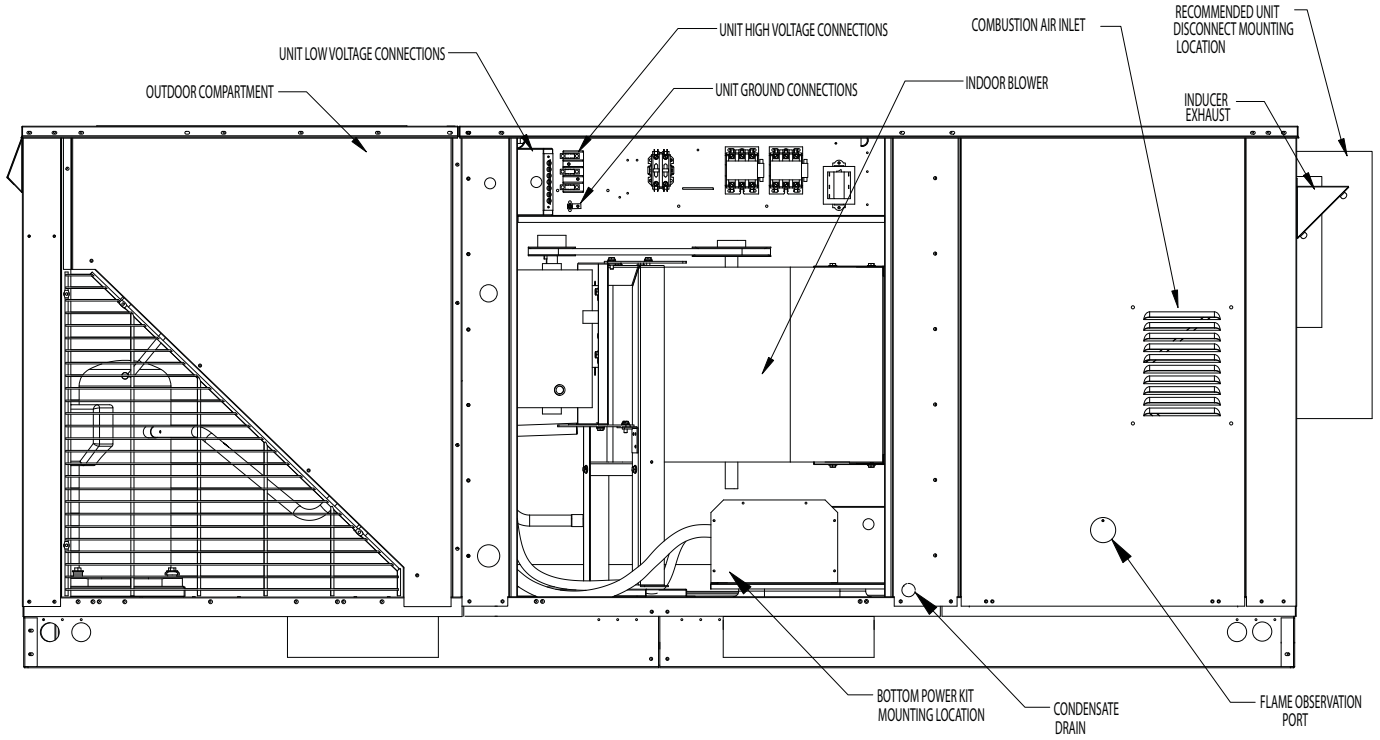

Figure 14. Unit Component Locations

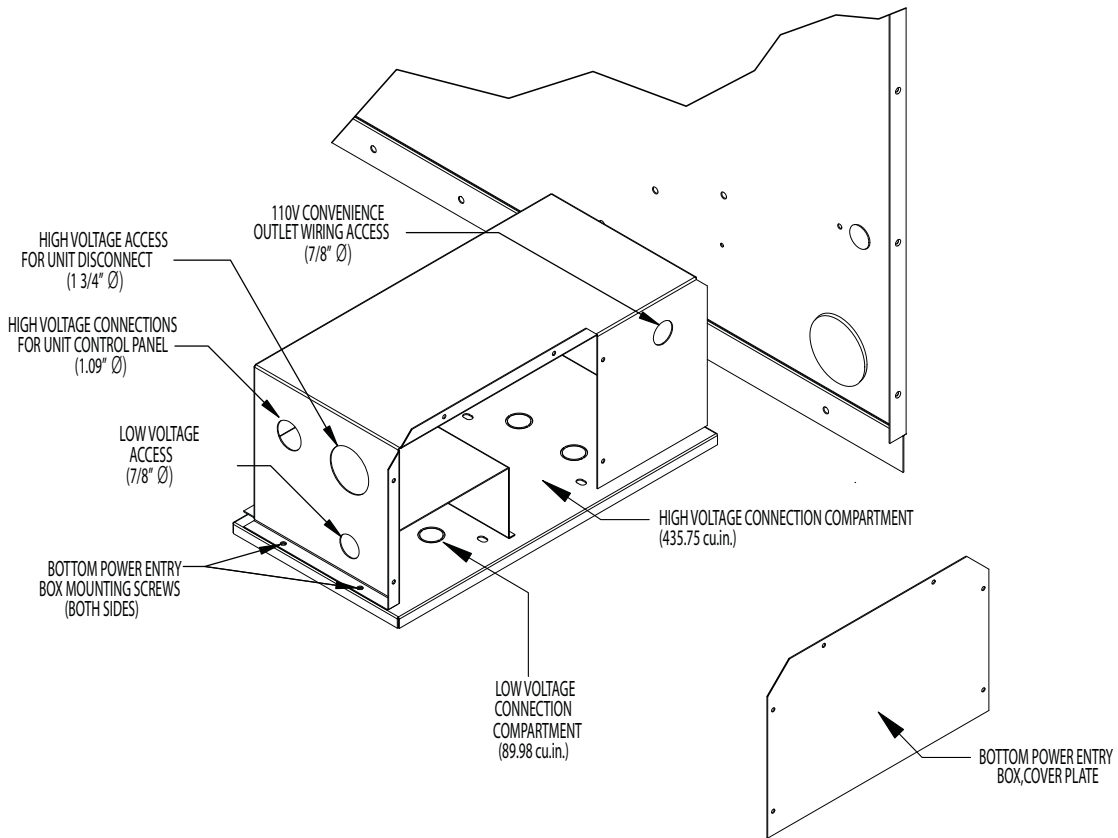

Figure 15. Bottom Power Kit

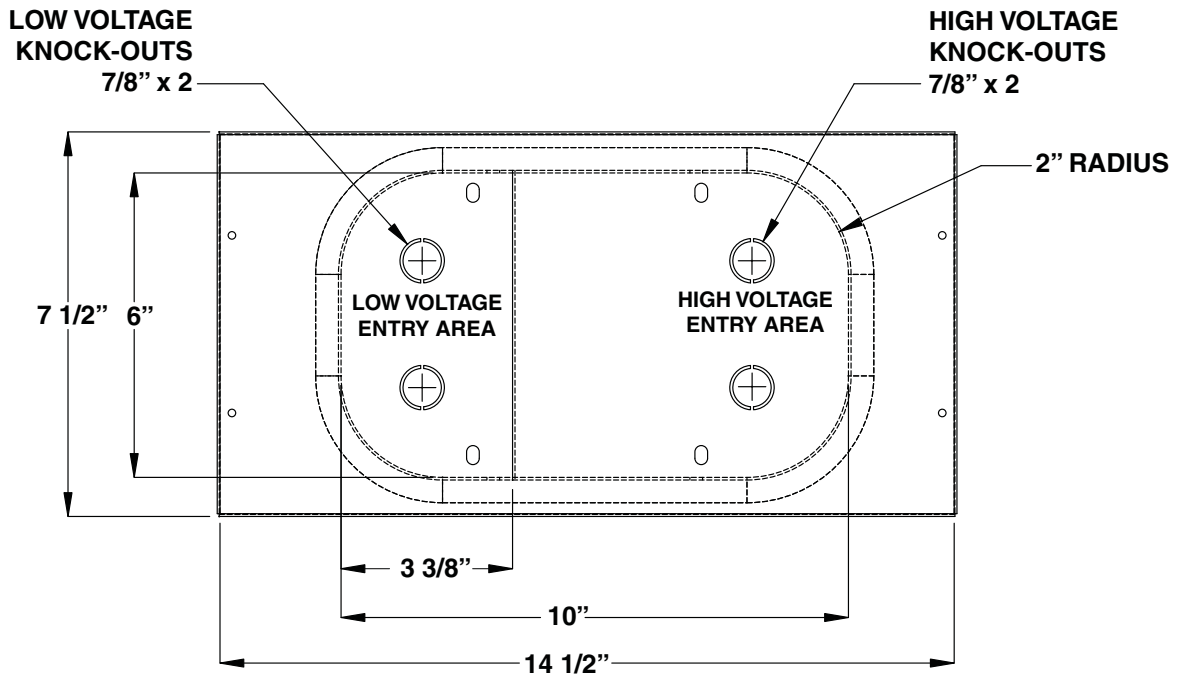

Figure 16. Bottom Power Entry Box Base Plate

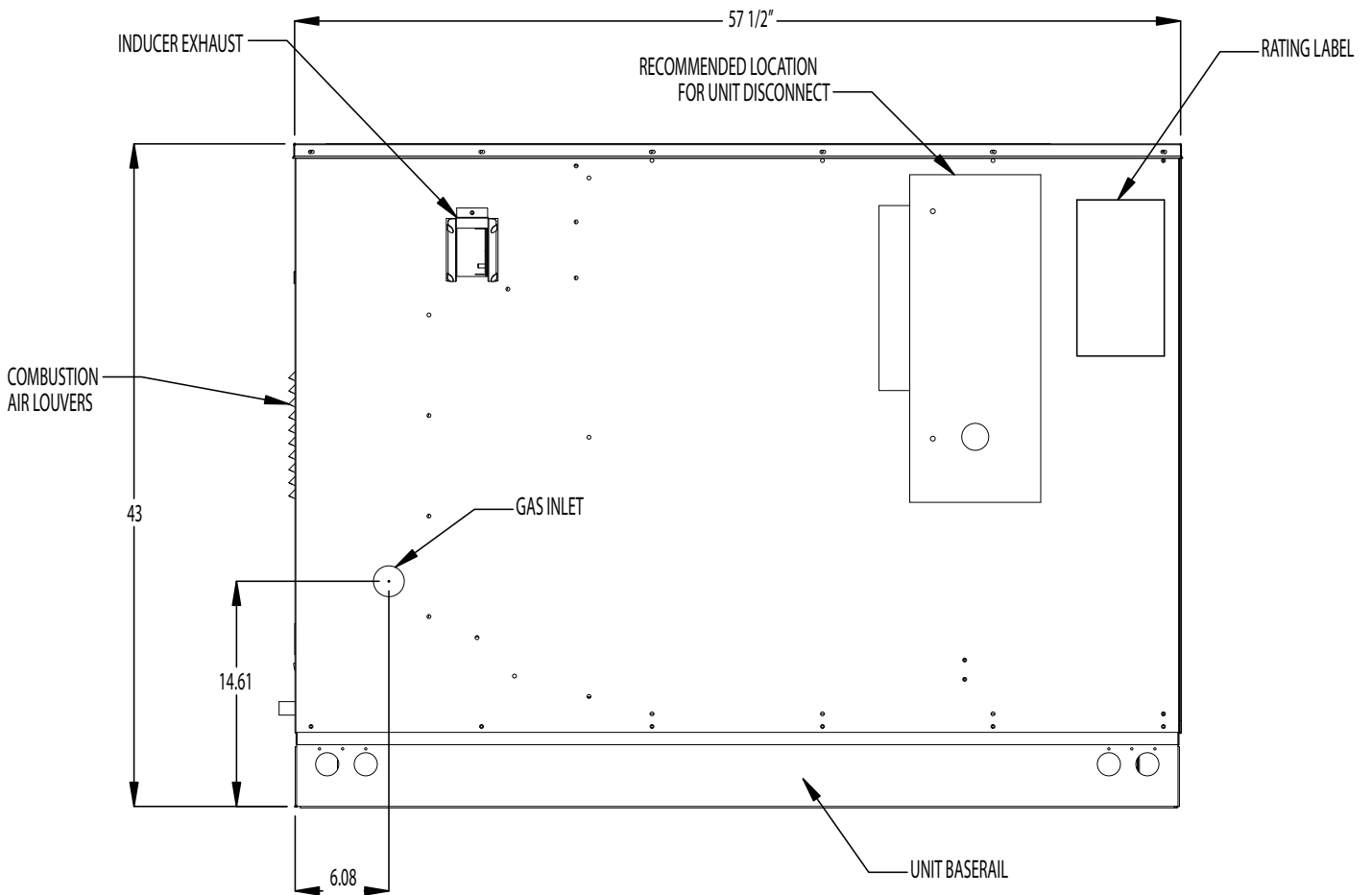

Figure 17. Side View

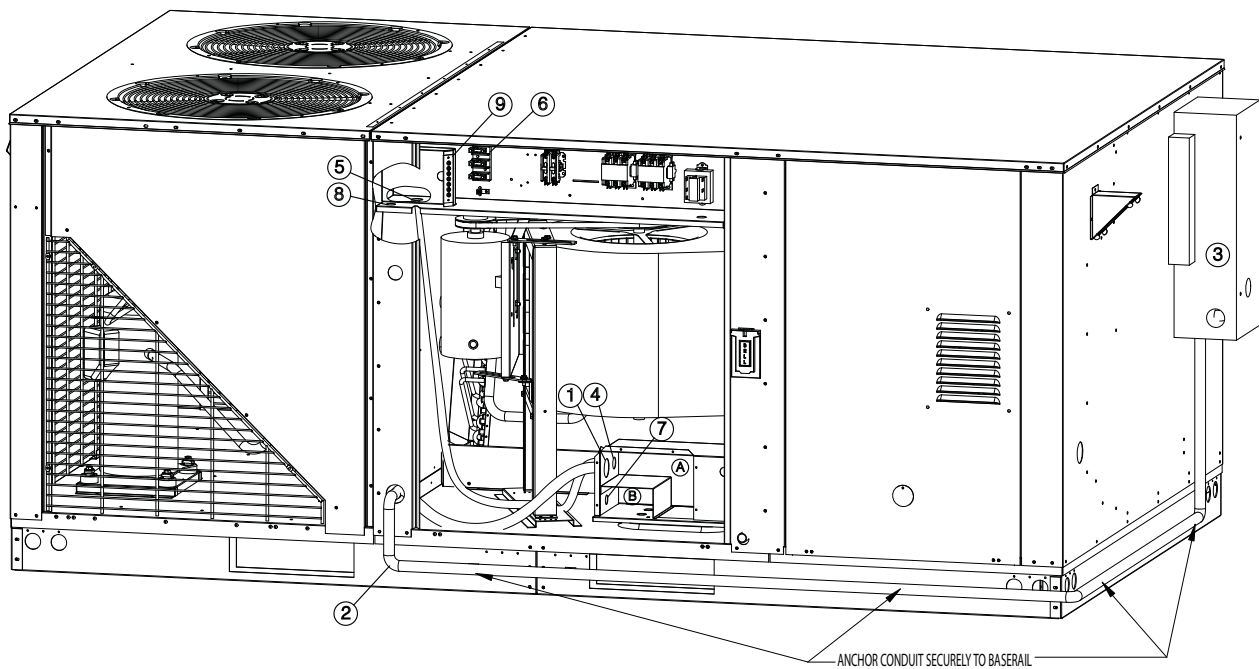

Figure 18. Wire Routing Diagram

Wire Routing Instructions

High Voltage Wiring

- Bring Branch Circuit wiring into Compartment (A)
- Route through FMC (1) through conduit (2) to disconnect (3).
- After disconnect, route wiring back through conduit (2) to compartment (A).
- Then route wires through FMC (4) to the unit control panel access (5) and make ground and power connections at location (6).

Low Voltage Wiring

- Bring thermostat wiring into Compartment (B).
- Route out at hole (7) to low voltage access hole (8).
- Make appropriate connections at location (9).



7089780