

INSTALLATION INSTRUCTIONS

Split System Air Conditioner - 3 phase, R-410A

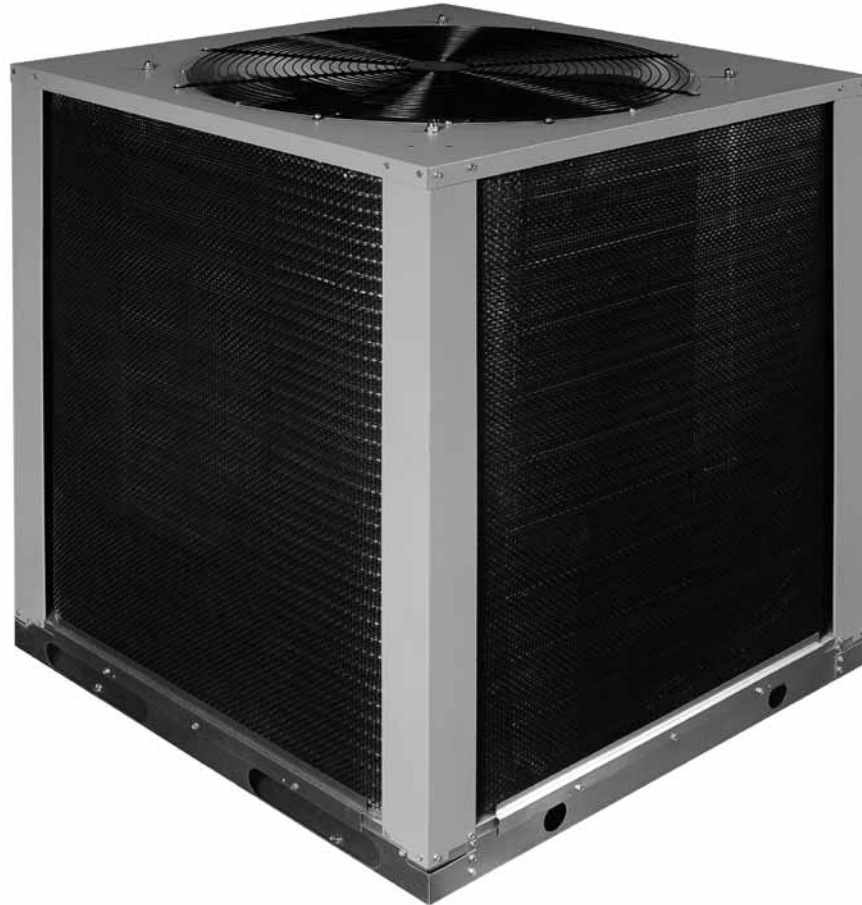

IMPORTANT

ATTENTION INSTALLERS:

It is your responsibility to know this product better than your customer. This includes being able to install the product according to strict safety guidelines and instructing the customer on how to operate and maintain the equipment for the life of the product. Safety should always be the deciding factor when installing this product and using common sense plays an important role as well. Pay attention to all safety warnings and any other special notes highlighted in the manual. Improper installation of the furnace or failure to follow safety warnings could result in serious injury, death, or property damage.

These instructions are primarily intended to assist qualified individuals experienced in the proper installation of this appliance. Some local codes require licensed installation/service personnel for this type of equipment. Please read all instructions carefully before starting the installation. Return these instructions to the customer's package for future reference.

DO NOT DESTROY. PLEASE READ CAREFULLY AND KEEP IN A SAFE PLACE FOR FUTURE REFERENCE.

TABLE OF CONTENTS

Important Safety Information	3		
Air Conditioner Installation	4	System Heating.....	8
General Information.....	4	Refrigerant Charging.....	8
Before You Install this Unit.....	4	Charging R410A Units in AC Mode with	
Locating the Air conditioner.....	4	Outdoor Temperatures Above 55° F.....	8
Packaging Removal.....	4	Air Conditioner Maintenance	9
Rigging & Hoisting.....	4	Component Functions	9
Rooftop.....	4	Replacement Parts	9
Ground Level.....	4	Figures & Tables	10
Connecting Refrigerant Tubing Between the		Table 3. S5BP Dimensions & Shipping Weights... 10	
Indoor & Outdoor Unit	5	Electrical Information.....	11
Electrical Wiring	5	Table 4. Electrical Specs & Physical Data	11
Pre - Electrical Checklist	5	Figure 3. S5BP Wiring Diagram	12
Line Voltage.....	6	Figure 4. Air conditioner T-stat Connections.....	13
Unbalanced 3-Phase Supply Voltage	6	Cooling Charging Charts.....	14
Thermostat Connections	7	Figure 5. Charging Chart for 7.5 Ton Units.....	15
Grounding.....	7	Figure 6. Charging Chart for 10 Ton Units.....	15
Optional Electric Heater Kits	7	INSTALLATION / PERFORMANCE CHECKLIST	16
Startup & Adjustments	7		
Pre - Start Checklist	7		
Start-up Procedures.....	7		
Air Circulation - Indoor Blower	7		
Anti-Short Cycle Timer Protection.....	8		
System Cooling.....	8		

IMPORTANT SAFETY INFORMATION

Please read all instructions before servicing this equipment. Pay attention to all safety warnings and any other special notes highlighted in the manual. Safety markings are used frequently throughout this manual to designate a degree or level of seriousness and should not be ignored. **WARNING** indicates a potentially hazardous situation that if not avoided, could result in personal injury or death. **CAUTION** indicates a potentially hazardous situation that if not avoided, may result in minor or moderate injury or property damage.

WARNING:

ELECTRICAL SHOCK, FIRE OR EXPLOSION HAZARD

Failure to follow safety warnings exactly could result in serious injury or property damage.

Improper servicing could result in dangerous operation, serious injury, death or property damage.

- **Before servicing, disconnect all electrical power to the indoor blower.**
 - **When servicing controls, label all wires prior to disconnecting. Reconnect wires correctly.**
 - **Verify proper operation after servicing.**
-

WARNING:

S5BP Split System Air conditioners leave the factory with a 90 oz. (5.63 Lbs.) R410A refrigerant holding charge. Follow all charging instructions for maximum unit performance and efficiency. Some local codes require licensed installation/service personnel to service this type of equipment. Refrigerant charging must be done by qualified personnel familiar with safe and environmentally responsible refrigerant handling procedures. Under no circumstances should the owner attempt to install and/or service this equipment. Failure to comply with this warning could result in property damage, personal injury, or death.

CAUTION:

This unit uses R-410A refrigerant. DO NOT use any other refrigerant in this unit. Use of another refrigerant will damage the unit.

WARNING:

The information listed below must be followed during the installation, service, and operation of this unit. Unqualified individuals should not attempt to interpret these instructions or install this equipment. If you do not possess mechanical skills or tools, call your local dealer for assistance. Failure to follow safety recommendations could result in possible damage to the equipment, serious personal injury or death.

- The installer must comply with all local codes and regulations which govern the installation of this type of equipment. Local codes and regulations take precedence over any recommendations contained in these instructions. Consult local building codes and the National Electrical Code (ANSI CI) for special installation requirements.
- All electrical wiring must be completed in accordance with local, state and national codes and regulations and with the National Electric Code (ANSI/NFPA 70) or in Canada the Canadian Electric Code Part 1 CSA C.22.1.
- This equipment contains liquid and gaseous refrigerant under high pressure. **DO NOT USE ANY PORTION OF THE CHARGE FOR PURGING OR LEAK TESTING.** Installation or servicing should only be performed by qualified trained personnel thoroughly familiar with this type equipment.
- Fully annealed, refrigerant grade copper tubing should be used when installing the system. Refrigerant suction line tubing should be fully insulated.
- Installation of equipment may require brazing operations. Installer must comply with safety codes and wear appropriate safety equipment (safety glasses, work gloves, fire extinguisher, etc.) when performing brazing operations.
- Use caution when handling this appliance or removing components. Personal injury can occur from sharp metal edges present in all sheet metal constructed equipment.
- This unit is designed for outdoor installations only and should be located in a position as shown on page 4.
- Follow all precautions in the literature, on tags, and on labels provided with the equipment. Read and thoroughly understand the instructions provided with the equipment prior to performing the installation and operational checkout of the equipment.
- The installer should become familiar with the units wiring diagram before making any electrical connections to the unit. See the unit wiring label or Figures 2 & 3 (pages 12 & 13).

AIR CONDITIONER INSTALLATION

General Information

The S5BP series air conditioner is designed only for outdoor rooftop or ground level installations. This unit has been tested for capacity and efficiency in accordance with AHRI Standards and will provide many years of safe and dependable comfort, providing it is properly installed and maintained. Abuse, improper use, and/or improper maintenance can shorten the life of the appliance and create unsafe hazards.

Before you install this unit

- √ The cooling load of the area to be conditioned must be calculated and a system of the proper capacity selected. It is recommended that the area to be conditioned be completely insulated and vapor sealed.
- √ Check the electrical supply and verify the power supply is adequate for unit operation. The system must be wired and provided with circuit protection in accordance with local building codes. If there is any question concerning the power supply, contact the local power company.
- √ The indoor section (air handler, furnace, etc) should be installed before routing the refrigerant tubing. Refer to the indoor unit's installation instructions for installation details.
- √ All units are securely packed at the time of shipment and upon arrival should be carefully inspected for damage prior to installing the equipment at the job site. Verify coil fins are straight. If necessary, comb fins to remove flattened or bent fins. Claims for damage (apparent or concealed) should be filed immediately with the carrier.
- √ Please consult your dealer for maintenance information and availability of maintenance contracts. Please read all instructions before installing the unit.

Locating the Air Conditioner

- Survey the job site to determine the best location for mounting the outdoor unit.
- Overhead obstructions (Figure 1), poorly ventilated areas, and areas subject to accumulation of debris should be avoided.
- Sufficient clearance for unobstructed airflow through the outdoor coil must be maintained in order to achieve rated performance. For minimum clearances to obstructions, see Figure 1.
- Consideration to minimum clearances should be given to availability of electric power, service access, noise, and shade.

Packaging Removal

Locate and remove all screws securing the unit to the shipping skid. **NOTE:** To prevent damage to the tubing connections, carefully remove the carton and user's manual from the equipment. Discard the shipping carton.

Rigging & Hoisting

WARNING:

To avoid the risk of property damage, personal injury, or death, it is the rigger's responsibility to ensure that whatever means are used to hoist the unit are safe and adequate:

- **The lifting equipment must be adequate for the load. Refer to Table 3 (page 10) for unit weights.**
- **The unit must be lifted from the holes in the base rails using cables or chains.**
- **Spreader bars are required to protect the unit and ensure even loading.**
- **Keep the unit in an upright position at all times.**
- **All panels must be securely in place during rigging and hoisting.**

Rooftop

Rooftop installations must be located according to local building codes or ordinances and these requirements:

- Units may be installed on Class A, B, or C roof covering material.
- The roof must be capable of handling the weight of the unit. Reinforce the roof if necessary. Support must be made of weather resistant materials and installed prior to unit installation. For unit weights, see Table 3 (pg. 10).
- Secure optional mounting pad or frame to roof using acceptable mechanical methods per local codes.

Ground Level

Ground level installations must be located according to local building codes or ordinances and these requirements. Clearances must be in accordance with those shown in Figure 1.

A suitable mounting pad must be provided and be separate from the building foundation. The pad must be level and strong enough to support the unit's weight. The slab height must be a minimum of 2" (5 cm) above grade and provide adequate drainage. See Figure 1.

Connecting Refrigerant Tubing Between the Indoor & Outdoor Unit

CAUTION:

This system uses R-410A refrigerant with POE oil. When servicing, cover or seal openings to minimize the exposure of the refrigerant system to air to prevent accumulation of moisture and other contaminants.

After outdoor and indoor unit placement has been determined, route refrigerant tubing between the equipment in accordance with sound installation practices.

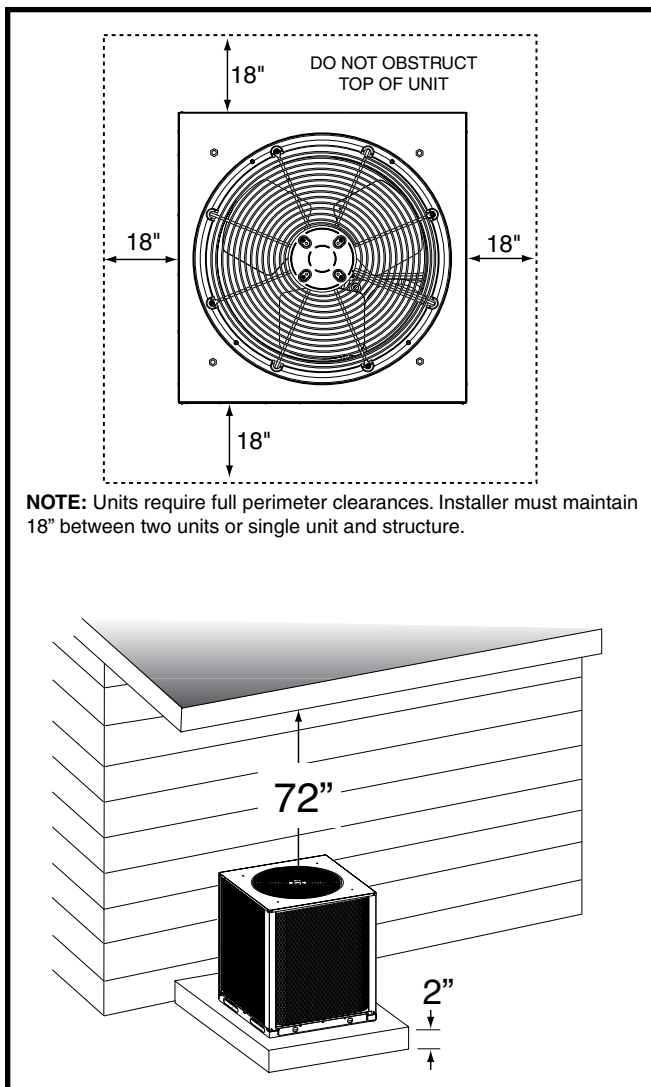

Figure 1. Minimum Clearance Requirements

- When connecting refrigerant linesets together, it is recommended that dry nitrogen be flowing through the joints during brazing. This will prevent internal oxidation and scaling from occurring.
- Refrigerant tubing should be routed in a manner that minimizes the length of tubing and the number of bends in the tubing.
- Refrigerant tubing should be supported in a manner that the tubing will not vibrate or abrade during system operation.
- Tubing should be kept clean of foreign debris during installation.
- Every effort should be made by the installer to ensure that the field installed refrigerant containing components of the system have been installed in accordance with these instructions and sound installation practices to insure reliable system operation and longevity.
- The maximum recommended interconnecting refrigerant line lengths are listed in Table 4 (page

13) and the vertical elevation difference between the indoor and outdoor sections should not exceed 20 feet.

- If precise forming of refrigerant lines is required, a copper tubing bender is recommended. Avoid sharp bends and contact of the refrigerant lines with metal surfaces.
- A filter dryer is provided with the unit and must be installed in the liquid line of the system. If the installation replaces a system with a filter dryer already present in the liquid line, the filter dryer must be replaced with the one supplied with the unit. The filter dryer must be installed in strict accordance with the manufacturer's installation instructions.
- Optional equipment such as liquid line solenoid valves, low ambient, etc., should be installed in strict accordance with the manufacturer's installation instructions.

ELECTRICAL WIRING

⚠ WARNING:

To avoid risk of electrical shock, personal injury, or death, disconnect all electrical power to the unit before performing any maintenance or service. The unit may have more than one electrical supply.

Label all wires prior to disconnection when servicing the unit. Wiring errors can cause improper and dangerous operation

- All electrical connections must be in compliance with all applicable local codes and ordinances, and with the current revision of the National Electric Code (ANSI/NFPA 70).
- For Canadian installations the electrical connections and grounding shall comply with the current Canadian Electrical Code (CSA C22.1 and/or local codes).

Pre-Electrical Checklist

- ✓ Verify that the voltage, frequency, and phase of the supply source match the specifications on the unit rating plate. Refer to Table 4 (page 11).
- ✓ Verify that the service provided by the utility is sufficient to handle the additional load imposed by this equipment. Refer to the unit wiring label for proper high and low voltage wiring.
- ✓ Verify factory wiring is in accordance with the unit wiring diagram (Figure 2, page 12). Inspect for loose connections.
- ✓ Phase balance on 3 phase units must always be checked. See Unbalanced 3-Phase Supply Voltage section (page 7).

Line Voltage

- A wiring diagram is located on the inside cover of the electrical box of the outdoor unit. The installer should become familiar with the wiring diagram before making any electrical connections to the outdoor unit.
- **An electrical disconnect must be located within sight of and readily accessible to the unit.** This switch shall be capable of electrically de-energizing the outdoor unit.
- Line voltage to the unit should be supplied from a dedicated branch circuit containing the correct fuse or circuit breaker for the unit. Incoming field wiring and minimum size of electrical conductors and circuit protection must be in compliance with information listed on the outdoor unit data label. Any other wiring methods must be acceptable to authority having jurisdiction.
- The outdoor unit requires both power and control circuit electrical connections. Refer to the wiring diagram / schematic for identification and location of outdoor unit field wiring interfaces. Make all electrical connections in accordance with all applicable codes and ordinances. See Figures 2 & 3 (pages 12 & 13).
- Overcurrent protection must be provided at the branch circuit distribution panel and sized as shown on the unit rating label and according to applicable local codes. See the unit rating plate for minimum circuit ampacity and maximum overcurrent protection limits.
- Provide power supply for the unit in accordance with the unit wiring diagram, and the unit rating plate. Connect the line-voltage leads to the terminals on the contactor inside the control compartment.
- Use only copper wire for the line voltage power supply to this unit as listed in Table 1. Use proper code agency listed conduit and a conduit connector for connecting the supply wires to the unit. Use of rain tight conduit is recommended.

- 208/230 Volt units are shipped from the factory wired for 230 volt operation. For 208V operation, remove the lead from the transformer terminal marked 240V and connect it to the terminal marked 208V.
- Optional equipment requiring connection to the power or control circuits must be wired in strict accordance of the NEC (ANSI/NFPA 70), applicable local codes, and the instructions provided with the equipment.

Unbalanced 3-Phase Supply Voltage

Voltage unbalance occurs when the voltages of all phases of a 3-phase power supply are no longer equal. This unbalance reduces motor efficiency and performance. Some underlying causes of voltage unbalance may include: Lack of symmetry in transmission lines, large single-phase loads, and unbalanced or overloaded transformers. A motor should never be operated when a phase imbalance in supply is greater than 2%.

Perform the following steps to determine the percentage of voltage imbalance:

1. Measure the line voltages of your 3-phase power supply where it enters the building and at a location that will only be dedicated to the unit installation (at the units circuit protection or disconnect).

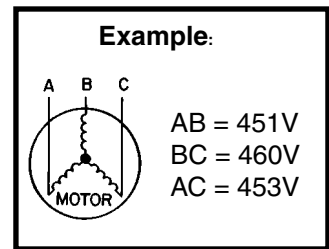

2. Determine the average voltage in the power supply.

In this example, the measured line voltages were 451, 460, and 453. The average would be 454 volts (451 + 460 + 453 = 1,364 / 3 = 454).

3. Determine the maximum deviation:

Example:
 From the values given in step 1, the BC voltage (460V) is the greatest difference in value from the average:
 $460 - 454 = 6$ ← Highest Value
 $454 - 451 = 3$
 $454 - 453 = 1$

4. Determine percent of voltage imbalance by using the results from steps 2 & 3 in the following equation.

Example:
 $100 \times \frac{6}{454} = 1.32\%$

$\% \text{ Voltage Imbalance} = 100 \times \frac{\text{max voltage deviation from average voltage}}{\text{average voltage}}$

COPPER WIRE SIZE — AWG (1% Voltage Drop)				
Supply Wire Length-Feet				Supply Circuit Ampacity
200	150	100	50	
6	8	10	14	15
4	6	8	12	20
4	6	8	10	25
4	4	6	10	30
3	4	6	8	35
3	4	6	8	40
2	3	4	6	45
2	3	4	6	50
2	3	4	6	55
1	2	3	4	60

Wire Size based on N.E.C. for 60° type copper conductors.

Table 1. Copper Wire Size

The amount of phase imbalance (1.32%) is satisfactory since the amount is lower than the maximum allowable 2%. Please contact your local electric utility company if your voltage imbalance is more than 2%.

Thermostat Connections

- Thermostat connections should be made in accordance with the instructions supplied with the thermostat and the indoor equipment.
- Single stage or two-stage thermostats can be used with this equipment depending on optional accessories (i.e. economizer) installed with the unit. Select a thermostat that operates in conjunction with the installed accessories. A typical commercial installation with an air conditioner thermostat and air handler is shown in Figure 3 (page 13).
- The outdoor unit is designed to operate from a 24 VAC Class II control circuit. The control circuit wiring must comply with the current provisions of the NEC (ANSI/NFPA 70) and with applicable local codes having jurisdiction.
- The low voltage wires must be properly connected to the units low voltage terminal block. Recommended wire gauge and wire lengths for typical thermostat connections are listed in Table 2.
- The thermostat should be mounted about 5 feet above the floor on an inside wall. DO NOT install the thermostat on an outside wall or any other location where its operation may be adversely affected by radiant heat from fireplaces, sunlight, or lighting fixtures, and convective heat from warm air registers or electrical appliances. Refer to the thermostat manufacturer’s instruction sheet for detailed mounting and installation information.

Thermostat Wire Gauge	Recommended T-Stat Wire Length (Unit to T-Stat)	
	2-Wire (Heating)	5-Wire (Heating/Cooling)
24	55	25
22	90	45
20	140	70
18	225	110

Table 2. Thermostat Wire Gauge

Grounding

⚠ WARNING:

The unit cabinet must have an uninterrupted or unbroken electrical ground to minimize personal injury if an electrical fault should occur. Do not use gas piping as an electrical ground!

This unit must be electrically grounded in accordance with local codes or, in the absence of local codes, with the National Electrical Code (ANSI/NFPA 70) or the CSA C22.1 Electrical Code. Use the grounding lug provided in the control box for grounding the unit.

Optional Electric Heater Kits

Optional field-installed electric heater kits are available in 10 kw through 36 kw heating capacities. Split System Air conditioners are designed to allow optional auxiliary electric heat to be field installed as required by the building’s particular heating load. The options available for each unit are shown in the heater kit installation instructions.

Install the heater kits as directed by the instructions supplied with the heater kit. Follow all cautions and warnings as directed.

START UP & ADJUSTMENTS

Pre-Start Check List

- ✓ Verify the indoor unit is level and allows proper condensate drainage.
- ✓ Verify the outdoor coil and top of the unit are free from obstructions and debris, and all equipment access/control panels are in place.
- ✓ Verify that the duct work is sealed to prevent air leakage.
- ✓ Verify that the line voltage power leads are securely connected and the unit is properly grounded.
- ✓ Verify the low voltage wires are securely connected to the correct leads on the low voltage terminal strip.
- ✓ Verify that the power supply branch circuit overcurrent protection is sized properly.
- ✓ Verify that the thermostat is wired correctly.

Start-Up Procedures

⚠ WARNING:

This unit is equipped with a crankcase heater. Allow 24 hours prior to continuing the start up procedures to allow for heating of the refrigerant compressor crankcase. Failure to comply may result in damage and could cause premature failure of the system. This warning should be followed at initial start up and any time the power has been removed for 12 hours or longer.

The thermostat's function mode should be set to OFF and the fan mode should be set to AUTO. Close all electrical disconnects to energize the system.

Air Circulation - Indoor Blower

1. Set the thermostat system mode on OFF and the fan mode to ON.
2. Verify the blower runs continuously. Check the air delivery at the supply registers and adjust register openings for balanced air distribution. If insufficient

air is detected, examine ductwork for leaks or obstructions.

3. Set the thermostat fan mode to AUTO and verify the blower stops running.

NOTE: On 3 phase air handler models only - If blower is spinning opposite of arrow direction, shut off the main power to the unit and switch any two field wires at the disconnect. **DO NOT alter unit wiring.**

Anti-Short Cycle Timer Protection

1. Set the thermostat system mode to COOL. Note the temperature setting of the thermostat and gradually raise the set-point temperature until the unit de-energizes.
2. Immediately lower the set point temperature of the thermostat to its original setting and verify that the indoor blower is energized and outdoor unit remains de-energized.
3. After approximately 5 minutes, verify the compressor and fan energize and the temperature of the discharge air is cooler than the room temperature.

System Cooling

1. Set the thermostat's system mode to COOL and the fan mode to AUTO. Gradually lower the thermostat temperature setpoint below room temperature and verify the outdoor unit and indoor blower energize.
2. Verify blower wheel is spinning in direction indicated by arrow. Feel the air being circulated by the indoor blower and verify that it is cooler than ambient temperature. Listen for any unusual noises. If unusual sounds occur, determine the source of the noise and correct as necessary.
3. Verify HI and LO refrigerant pressures.
NOTE: If refrigerant pressures are abnormal and the compressor is rotating backwards, shut off main power to the unit and switch any two field wires at the disconnect. **DO NOT alter unit wiring.**
4. Allow the system to operate for several minutes and then set the temperature selector above room temperature. Verify the fan and compressor cycle off with the thermostat. **NOTE:** The blower should also stop unless fan mode is set to the ON position.

System Heating (optional)

1. Set the thermostat's system mode to HEAT and the temperature mode above room temperature.
2. Verify the optional heating equipment (furnace or electric heat) and indoor blower energize. Feel the air being circulated by the indoor blower and verify that it is warmer than ambient temperature. Listen for any unusual noises. If unusual sounds occur, determine the source of the noise and correct as necessary.

Refrigerant Charging

WARNING:

S5BP Split System Air Conditioners leave the factory with a 90 oz. (5.63 Lbs.) R410A refrigerant holding charge. Follow these charging instructions for maximum unit performance and efficiency. Some local codes require licensed installation/service personnel to service this type of equipment. Refrigerant charging must be done by qualified personnel familiar with safe and environmentally responsible refrigerant handling procedures. Under no circumstances should the owner attempt to install and/or service this equipment. Failure to comply with this warning could result in property damage, personal injury, or death.

After refrigerant line connections are completed, it is required that you leak check and evacuate the indoor section and all line connections (using proper methods) before finalizing the full system refrigerant charge. For final charges based on matched systems and specified line lengths, see physical and electrical specifications (Table 4, page 11).

- To achieve rated capacity and efficiency the compressor must be exposed to refrigerant for at least 24 hours prior to running and then the compressor must be run for a minimum of 12 hours.
- Refrigerant charging charts (Figures 4 & 5) are applicable only to matched assemblies of NORDYNE equipment and listed airflows for the indoor coil. S5BP outdoor units with indoor coils not listed are not recommended and deviations from rated airflows or non-listed combinations may require modification to the expansion device and refrigerant charging procedures for proper and efficient system operation. See pages 14 & 15.
- The refrigerant charge can be checked and adjusted through the service ports provided external to the outdoor unit. Use only gage line sets which have a "Schraeder" depression device present to actuate the valve.

Charging an R410A system in AC mode at outdoor temperatures above 55° F for optimized sub-cooling of 10° F - 12° F.

1. With the system operating at steady-state, measure the liquid refrigerant pressure (in PSIG) at the outdoor unit service valve.
2. Measure the liquid refrigerant temperature (in Fahrenheit) at the service valve.
3. Determine the required liquid refrigerant pressure from the appropriate charging chart (Figures 4 or 5).
 - If the pressure measured in Step 1 is greater than

the required liquid refrigerant pressure determined in Step 3, then there is too much charge in the system. Remove refrigerant and repeat Steps 1 through 3 until the system is correctly charged.

- If the pressure measured in Step 1 is less than the required liquid refrigerant pressure determined in Step 3, there is too little charge in the system. Add refrigerant and repeat Steps 1 through 3 until the system is correctly charged.

AIR CONDITIONER MAINTENANCE

WARNING:

To prevent electrical shock, personal injury, or death, disconnect all electrical power to the unit before performing any maintenance or service. The unit may have more than one electrical supply.

Proper maintenance is important to achieve optimum performance from the air conditioner. The ability to properly perform maintenance on this equipment requires certain mechanical skills and tools. If you do not possess these skills, contact your dealer for maintenance. Consult your local dealer about the availability of maintenance contracts. Routine maintenance should include the following:

- Inspect and clean or replace air filters at the beginning of each heating and cooling season, or more frequently if required.
- Inspect the condensate drain and outdoor coil at the beginning of each cooling season. Remove any debris. Clean the outdoor coil and louvers as necessary using a mild detergent and water. Rinse thoroughly with water.
- Inspect the electrical connections for tightness at the beginning of each heating and cooling season. Service as necessary.

CAUTION:

The unit should never be operated without a filter in the return air system. Replace disposable filters with the same type and size.

- Do not attempt to add additional oil to motors unequipped with oil tubes. The compressor is hermetically sealed at the factory and does not require lubrication.

COMPONENT FUNCTIONS

Anti-Short Cycle Timer (ASCT)

A protective short cycle timer is factory installed and located in the control panel of the outdoor section. If power to the compressor low voltage control circuit is interrupted, the outdoor unit will not energize for approximately 5 minutes.

High Pressure Switch (HPS)

A high-pressure switch is factory-installed and located in the liquid line internal to the outdoor unit. The switch is designed to protect the system when very high pressures occur during abnormal conditions. Under normal conditions, the switch is closed. If the liquid pressure rises above 650 psig, then the switch will open and de-energize the outdoor unit. The switch will close again once the liquid pressure decreases to 460 psig. Please note that the switch interrupts the thermostat inputs to the unit. Thus, when the switch opens and then closes, there will be a 5 minute short cycling delay before the outdoor unit will energize.

Low Pressure Switch (LPS)

A low-pressure switch is factory-installed and located in the suction line internal to the outdoor unit. The switch is designed to protect the compressor from a loss of charge. Under normal conditions, the switch is closed. If the suction pressure falls below 5 psig, then the switch will open and de-energize the outdoor unit. The switch will close again once the suction pressure increases above 20 psig. Please note that the switch interrupts the thermostat inputs to the unit. Thus, when the switch opens and then closes, there will be a 5 minute short cycling delay before the outdoor unit will energize.

REPLACEMENT PARTS

Replacement parts are available through all Nordyne distributors. Please have the complete model and serial number of the unit when ordering replacement parts.

Electrical:

Capacitors	Temperature Limit Switches
Compressors	Thermostats
Contactors	Time Delay Relays
Pressure Switches	Transformers
Relays	

Motors:

Blower Motor
Fan Motor

Components:

Blower Assembly	Fan Grille
Cabinet Panels	Filter/Driers
Expansion Valves	

FIGURES & TABLES

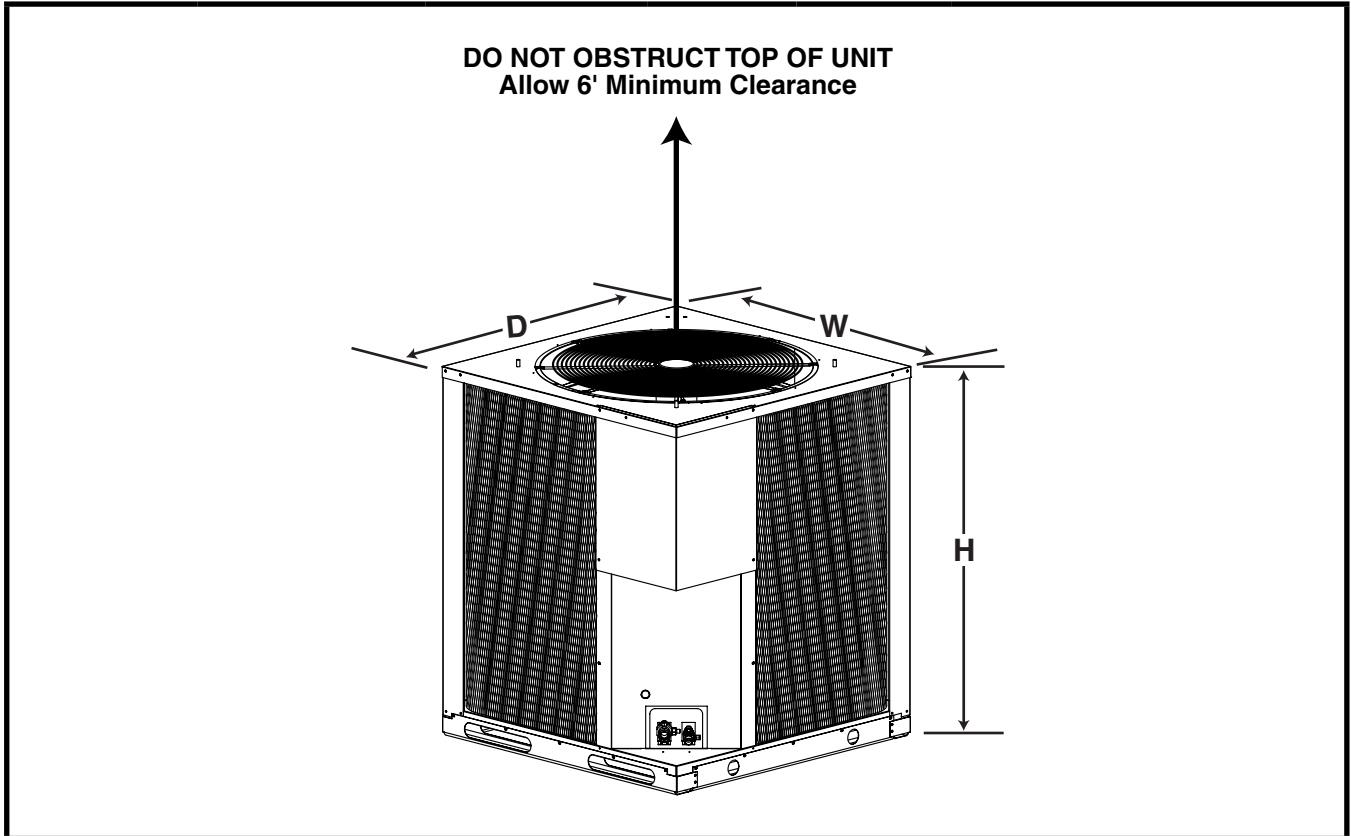

Model Number S5BP-	Unit Weights (Lbs.)		Height -H-	Width -W-	Depth -D-	Shipping Height
	Without Packaging	Shipping Weight				
			All dimensions in inches			
090C	386	420	44 1/4	37 1/2	37 1/2	50
090D	386	420	44 1/4	37 1/2	37 1/2	50
120C	423	457	52 1/4	37 1/2	37 1/2	58
120D	423	457	52 1/4	37 1/2	37 1/2	58

Table 3. S5BP Dimensions & Shipping Weights

ELECTRICAL INFORMATION

Model Number S5BP-	090C	090D	120C	120D
	208-230V	460V	208-230V	460V
	920888	920889	920890	920891
PERFORMANCE DATA				
Gross Cooling Capacity (95°F) Btuh	92,400	92,400	121,700	121,700
¹ Net Cooling Capacity - Btuh	90,000	90,000	117,000	117,000
¹ A.R.I. Rated Airflow - C.F.M.	3,000	3,000	4,000	4,000
² Cooling - Efficiency E.E.R. (Btu/Watt)	11.20	11.20	11.20	11.20
³ Cooling - Efficiency I.E.E.R.	11.50	11.50	11.50	11.50
ELECTRICAL RATINGS				
Volts / Phase / Hz.	208-230 / 3 / 60	460 / 3 / 60	208-230 / 3 / 60	460 / 3 / 60
Operating Voltage	187-253	414-506	187-253	414-506
Unit Rated Ampacity	28.3	13.9	33.4	18.4
Minimum Circuit Ampacity (MCA)	34.6	17.0	40.9	22.6
⁴ Max. Overcurrent Protection (MOP)	50	25	70	35
Compressor Data:	1 ea.	1 ea.	1 ea.	1 ea.
Compressor (Scroll)	ZP83KCE-TF5	ZP83KCE-TFD	ZP103KCE-TF5	ZP103KCE-TFD
Volts / Phase / Hz.	208-230 / 3 / 60	460 / 3 / 60	208-230 / 3 / 60	460 / 3 / 60
Rated Load Amps (RLA)	25.0	12.2	30.1	16.7
Lock Rotor Amps (LRA)	164	100	225	114
Stages / Percent	1 / 100	1 / 100	1 / 100	1 / 100
Crankcase Heater - Qty. / Type	1 / Band	1 / Band	1 / Band	1 / Band
Outdoor Fan Assembly:	1 ea.	1 ea.	1 ea.	1 ea.
Volts / Phase / Hz.	208-230 / 1 / 60	460 / 1 / 60	208-230 / 1 / 60	460 / 1 / 60
Motor - HP / RPM	3/4 - 875	3/4 - 875	3/4 - 875	3/4 - 875
Motor Amps	3.3	1.7	3.3	1.7
Fan Blade - Diameter / Pitch / # Blades	30" / 22 / 3	30" / 22 / 3	30" / 26 / 3	30" / 26 / 3
RPM / CFM (Max. - Total)	850 - 7,200	850 - 7,200	850 - 8,000	850 - 8,000
PHYSICAL DATA & REFRIGERANT SPECS				
Outdoor Coil Assembly:	1 ea.	1 ea.	1 ea.	1 ea.
Area (Ft. ²)	31.94	31.94	38.33	38.33
Rows - FPI	2 - 16	2 - 16	2 - 18	2 - 18
Tube Diameter	3/8" OD	3/8" OD	3/8" OD	3/8" OD
Refrigerant Suction Line - Length / OD	0 - 75 Ft. / 1-1/8" 76 - 100 Ft. / 1-3/8" ⁽⁶⁾	0 - 75 Ft. / 1-1/8" 76 - 100 Ft. / 1-3/8" ⁽⁶⁾	0 - 100 Ft. / 1-3/8" ⁽⁶⁾	0 - 100 Ft. / 1-3/8" ⁽⁶⁾
Refrigerant Liquid Line - Length / OD	All Lengths - 5/8" OD	All Lengths - 5/8" OD	All Lengths - 5/8" OD	All Lengths - 5/8" OD
Refrigerant Charge.	R410A	R410A	R410A	R410A
Factory Holding Charge - oz	90	90	90	90
⁵ Total System with 25' Line Set	416	416	520	520
High Pressure Switch (PSIG)	Cut Out: 650 +/- 15 Cut In: 460 +/- 15			
Loss of Charge Pressure Switch (PSIG)	Cut Out: 5 +/- 5 Cut In: 20 +/- 5			
Net Unit Weight - Lbs. (No Packaging)	386	386	423	423
Approximate Shipping Weight - Lbs.	420	420	457	457

Note: Net capacity includes indoor blower motor heat deduction. Gross capacity does not include indoor blower motor heat deduction.

¹ Certified in accordance with A.R.I. Standard 340/360 at 95° F Outdoor DB and 80° F db/67° F wb evaporator entering air at minimum external duct static pressures allowed by the standard.

² E.E.R. - Energy Efficiency Ratio. E.E.R. is determined @ 95° F Outdoor DB & 80° F DB / 67° F WB Air Indoor

³ I.E.E.R. - Integrated Energy Efficiency Ratio. Certified in accordance with A.R.I. Standard 340/360.

⁴ Delay Fuse or HACR Type Curcuit Breakers can be used.

⁵ Add / Subtract 9.0 oz. of refrigerant per 5 feet change in length from original 25 Ft. lineset total system charge.

⁶ Requires a 1-3/8" to 1-1/8" reducer line to unit.

Table 4. Electrical Specifications & Physical Data - 11.2 E.E.R. - 3 Phase / 60 Hz

WIRING DIAGRAM

Commercial Split System Air Conditioner (Outdoor section)

Three Phase

NOTES:

1. Disconnect all power before servicing.
2. For supply connections, use copper conductors only.
3. Furnace/Air Handler w/factory equipped 24 V control circuit transformers, should be modified/rewired to ONLY use 24V transformer from outdoor section. See installation instructions for typical modifications.
4. For replacement wires, use conductors suitable for 105° C
5. For ampacities and overcurrent protection, see unit rating plate.
6. Wires connected to normally closed contacts.
7. Transformer primary connection will match unit rated voltage.
8. For 208V operation remove white wire from 230V tap and place on 208V tap.
9. For 415/420V operation remove white wire from 380V tap and place on 415V tap.

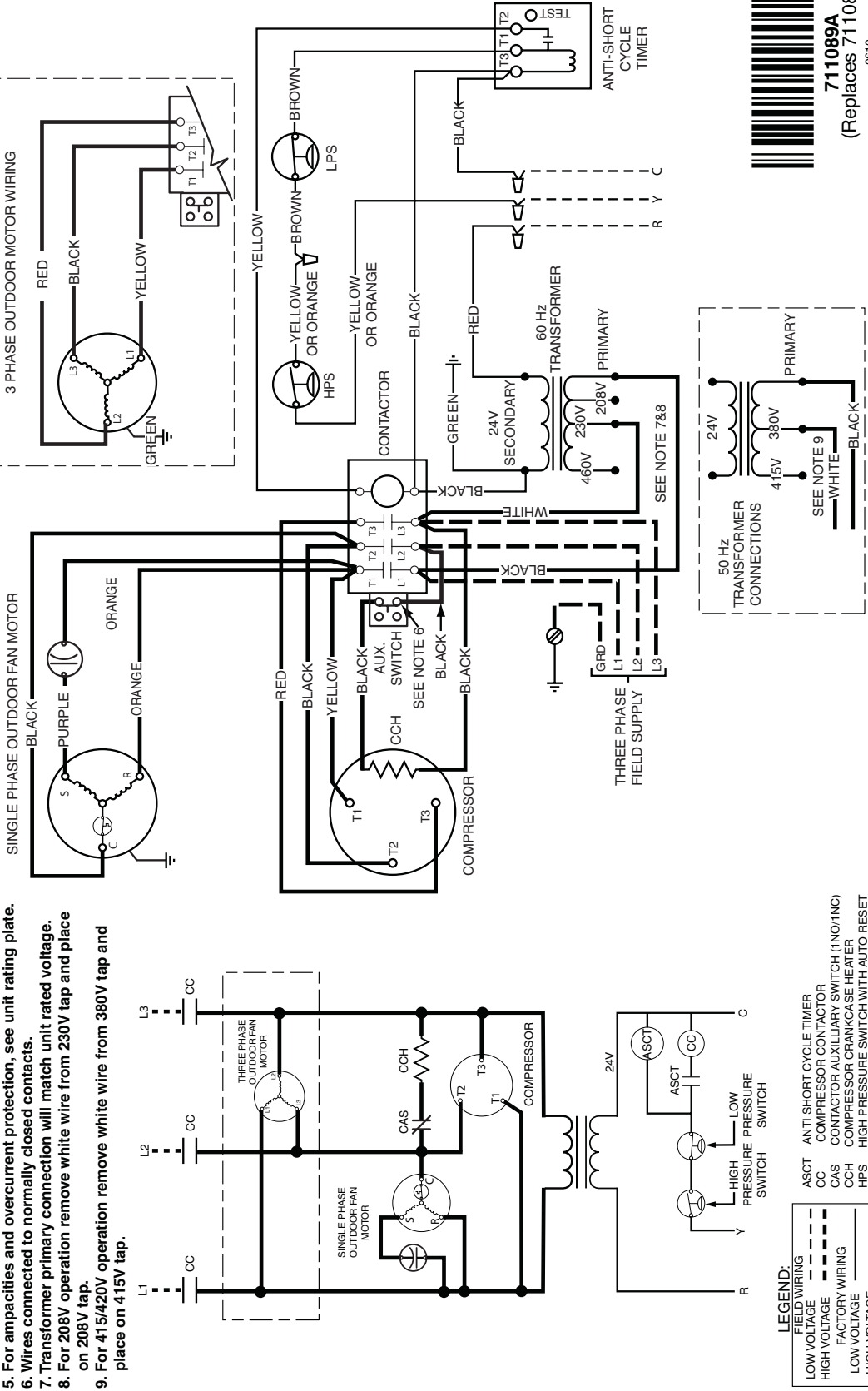

711089A
(Replaces 7110890)

0610

Figure 2. S5BP Wiring Diagram

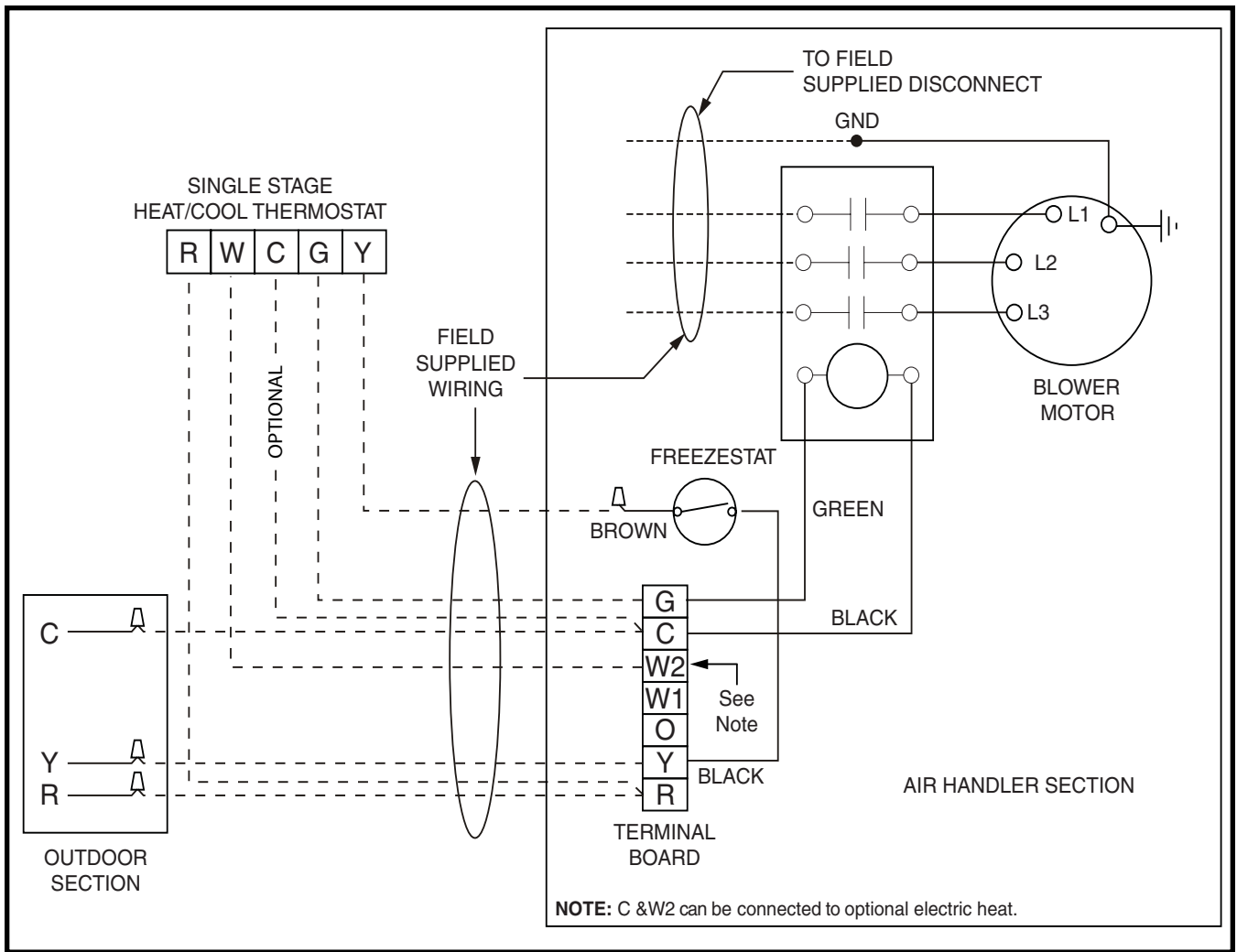

Figure 3. Typical Single Stage Heat / Cool Thermostat Connection

S5BP CHARGING CHARTS - COOLING ONLY

Application Notes on the Use of Charging Charts

- **This equipment's cooling system contains refrigerant under high pressure. Always use safe and environmentally sound methods when handling refrigerant handling or servicing the unit. Review the factory literature and safety warnings prior to servicing.**
- When repairing system leakages, always use a nitrogen (inert) gas to protect the refrigerant system and pressure check the repair before re-charging. Always replace the filter-dryers when performing any repair to the refrigeration system with one capable of acid removal. After completing the repairs, evacuate the system to 350 - 500 microns and weigh in the refrigerant to the amount specified on the unit rating label.
- All S5BP-090/120 units are shipped from the factory with a 90 oz. holding charge refrigerant. Inspect the unit rating label to determine the units information prior to working on the system. **DO NOT** mix different refrigerants or charge the unit with a refrigerant not listed on the unit rating label.
- The refrigerant charging charts are valid for a variety of indoor return air conditions and are most influenced by the outdoor ambient temperature, outdoor fan operation, and the unit operating voltage. Before using these charts, ensure the unit is in a stable operating mode. As shown in Figures 4 or 5 (page 15), the ideal system sub-cooling can vary over the range of operation. Reference the charts to determine the ideal amount of sub-cooling for a given liquid pressure. Units charged to other values will not perform at the rated unit efficiency (EER) or rated Coefficient of Performance (COP) in heating mode.
- To inspect a systems operation, using quality instruments, match the measured liquid temperature to the units chart. The measured liquid pressure reading should be within 3% of the charts value for most installations.
- For systems that are operating with more than a 5% deviation, inspect the unit for the proper voltage and phase balance and the refrigeration system for leaks.
- Units that are operating at less then 95% of the nominal voltage or with a 2% phase imbalance may see a more significant deviation than the amount stated above.
- **DO NOT** use the charts in systems that have a fan cycling under low-ambient control. Refer to the low-ambient kit instructions for more information. (If applicable)

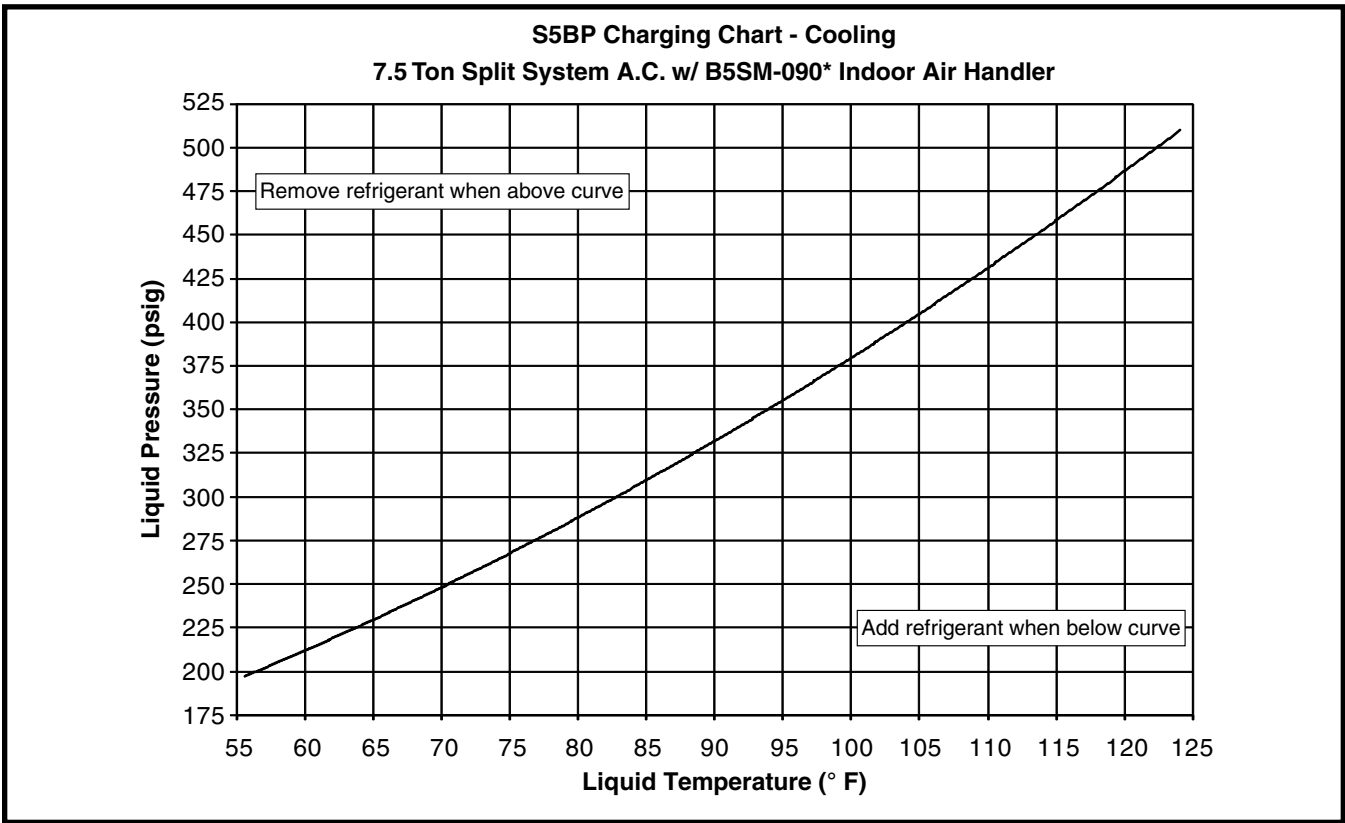

Figure 4. Charging Chart for 7.5 Ton Units

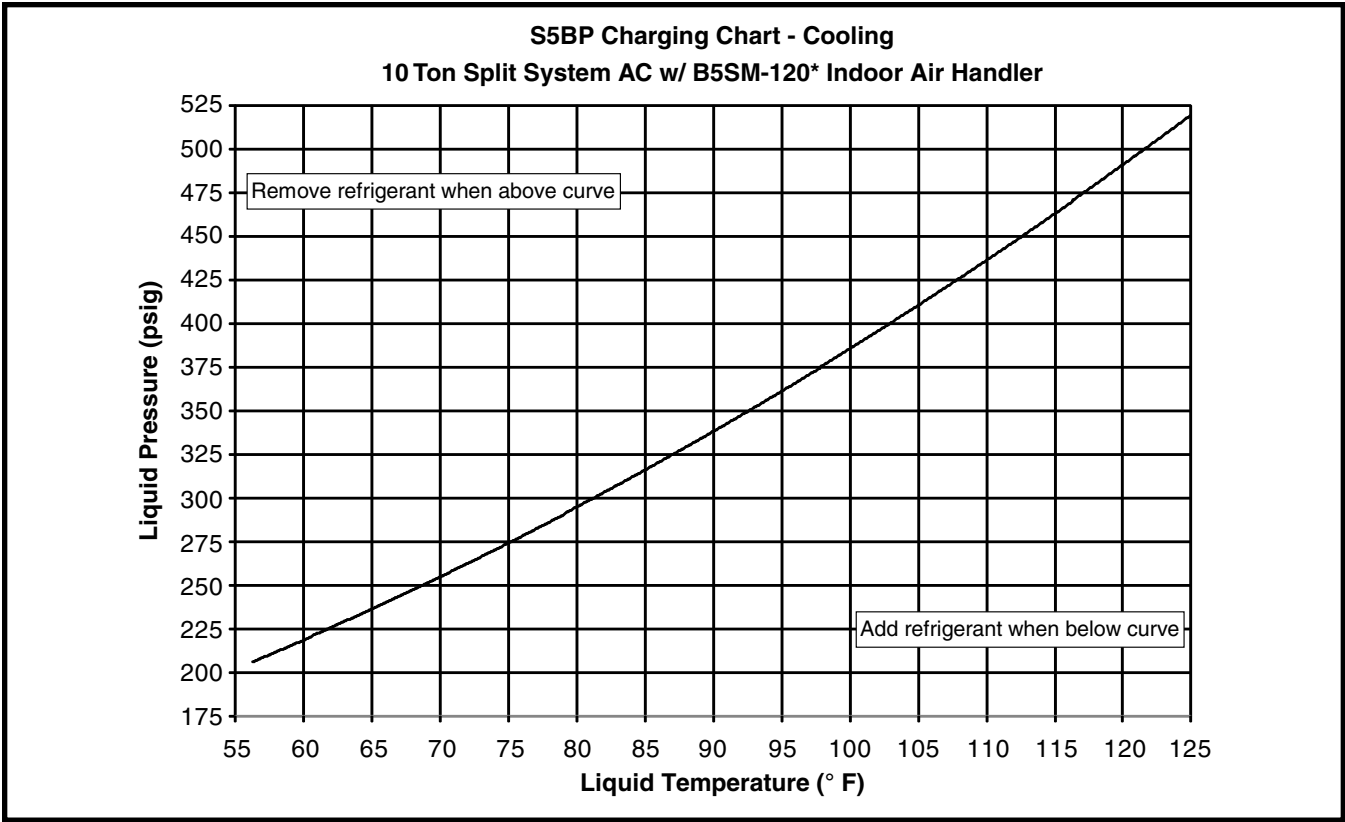

Figure 5. Charging Chart for 10 Ton Units

INSTALLATION / PERFORMANCE CHECK LIST

INSTALLATION ADDRESS:		
City _____	State _____	
Unit Model # _____		
Unit Serial # _____		
Unit Installed Minimum clearances per Figure 1 (page 4)?	YES	NO
INSTALLER NAME:		
City _____	State _____	

REFRIGERATION SYSTEM:		
Was unit given 24 hr warm up period for crankcase heaters?	YES	NO
Stage-1 Liquid Pressure (high side) _____		
Stage-1 Suction Pressure (low side) _____		
Has the owner's information been reviewed with the customer?	YES	NO
Has the Literature Package been left with the unit?	YES	NO

ELECTRICAL SYSTEM:		
Electrical connections tight?	YES	NO
Line voltage polarity correct?	YES	NO
Rated Voltage: _____ VOLTS		
L1-L2 Volts: _____ VOLTS		
L1-L3 Volts: _____ VOLTS		
L2-L3 Volts: _____ VOLTS		
Avg. Volts: _____ VOLTS		
Max. deviation of voltage from avg. volts: _____ VOLTS		
% Volt imbalance: _____ VOLTS		
Blower Motor HP: _____ Sheave Setting _____ # Turns		
Has the thermostat been calibrated?	YES	NO
Is the thermostat level?	YES	NO
Is the heat anticipator setting correct? (If Applicable)	YES	NO



NORDYNE
COMPLETE COMFORT. GENUINE VALUE.



Specifications & illustrations subject to change without notice or incurring obligations.
O'Fallon, MO | Printed in U.S.A. (11/11)

709093C (Replaces 709093B)