



**Replacement Parts**

Applies to: **Reznor Direct-Fired Equipment with Electronic Modulation**

**Replacement Kit P/N 268301 for Maxitrol Amplifier in Electronic Modulation Option AG30, AG31, AG32, or AG35 AND Replacement Kit P/N 268302 for Maxitrol Amplifier in Electronic Modulation Option AG33**

**Application and Components**

These replacement amplifiers function the same as the original, but when replacing an older amplifier, there are different installation and wiring requirements.

<p>P/N 148590, Maxitrol Model A1014R</p> 	<p>P/N 268274, Maxitrol Model A1044U (cover removed)</p> 	
Kit	Use this kit to replace:	Kit Components
<p>P/N 268301</p>	<p>Amplifier P/N 148590, Model A1014U or A1014L, or amplifier P/N 86976, Model A1014, in Electronic Modulation Option AG30, AG31, AG32, or AG35.</p>	<p>Amplifier, P/N 148590, A1014R                  (10) Wire Terminals, P/N 1350</p>
<p>P/N 268302</p>	<p>Amplifier P/N 86989, 119616, 157915, or 194159 in Electronic Modulation Option AG33.</p>	<p>Amplifier, P/N 268274, A1044U                  (2) Screws, P/N 38529                  (10) Wire Terminals, P/N 142860</p>

**Instructions**

1. Turn off the gas and disconnect the power.
2. Locate the amplifier being replaced. Mark and disconnect the wires from the amplifier. If installing Kit P/N 268302, make note of the temperature settings. Remove the amplifier.
3. Follow the appropriate instructions to install the replacement amplifier:

**Section applies only to Kit P/N 268301**

**NOTE:** When Step 3 is completed, continue to Steps 4 & 5 on page 2.

**If installing Kit P/N 268301** which replaces amplifier Model A1014U or A1014L (also P/N 148590) and amplifier Model A1014, refer to **DIAGRAM 1** below.

- a) Attach the replacement amplifier with the screws supplied.
- b) Locate all of the disconnected amplifier wires (Step 2). Attach the “fork” terminals in the kit to all wires (replacing any existing terminals). Refer to replacement amplifier section of **DIAGRAM 1** and connect the wires.
- c) On the upper left corner of the replacement amplifier, find two recessed dip switches. Set the dips switches to the positions shown in **DIAGRAM 1**.

**DIAGRAM 1 - applies to replacement amplifier in electronic modulation Options AG30, AG31, AG32, and AG35**

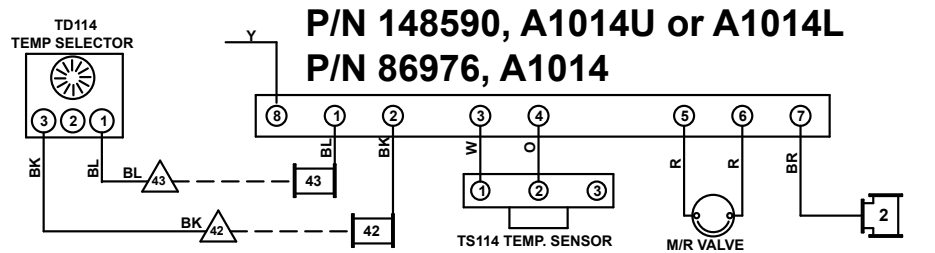

**REPLACEMENT Amplifier, P/N 148590, A1014R**

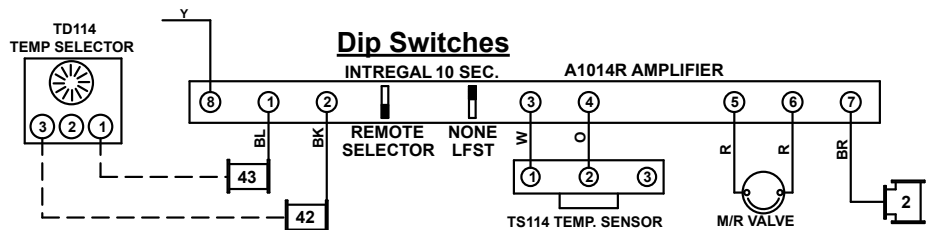

**Section applies only to Kit P/N 268302**

**If installing Kit P/N 268302** which replaces amplifier P/N 86989, 119616, 157915, or 194159, refer to **DIAGRAM 2**, page 2.

- a) The temperature range on the amplifier dials must match the temperature range of the sensor. The Model A1044U replacement amplifier (P/N 268274) is

## Instructions - Step 3 (cont'd)

### Section applies only to Kit P/N 268302 (cont'd)

adaptable to work with sensor Models TS144, TS144C, and TS144E. Check the model number displayed on the sensor and follow the instructions that apply.

**Sensor TS144** - No change required.

**Sensor TS144C** - Change the "Min" label to 20° - 60°.

**Sensor TS144E** - Change the "Min" label to 20° - 60° and the "Max" label to 60° - 120°.

Find the labels included with the amplifier and select the one or two that will be needed. Do not remove the existing dial label but be sure that it is clean and dry. Remove the adhesive backing and carefully slide the replacement label under the temperature pointer. Line up

with the center leg and adhere the label.

### Temperature Dials on Model A1044U Amplifier

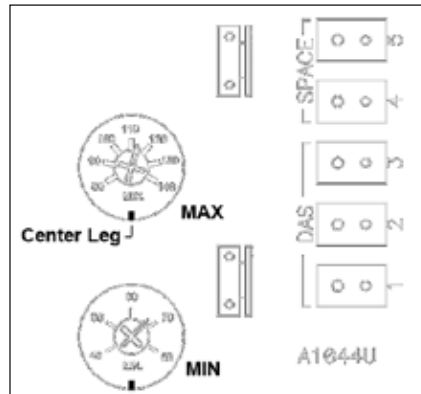

**b)** Position the mounting rail for the new amplifier over the same area where the old amplifier was

mounted. Mark the two mounting holes. Drill 7/64" pilot holes. Attach the rail using the screws provided. Carefully attach the amplifier to the mounting rail.

**c)** Locate all of the disconnected amplifier wires (Step 2) and cut off their terminals. Replace with the insulated terminals in the kit. Refer to replacement amplifier in **DIAGRAM 2** and connect the wires.

**d)** In the center on the lower portion of the amplifier, locate "J5". Move the jumper to the 20 second position as shown on the replacement amplifier in **DIAGRAM 2**.

Set the dials to the temperature settings of the removed amplifier. Install the amplifier cover.

### DIAGRAM 2 - applies to replacement amplifier in electronic modulation Option AG33

#### A1044 or A1044E Amplifier

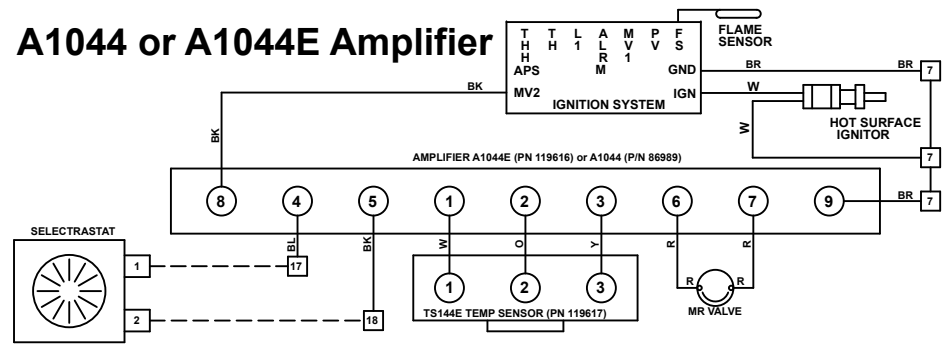

#### A1044EL or A1044CL Amplifier

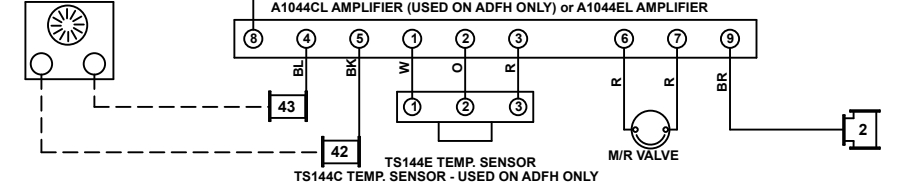

### REPLACEMENT Amplifier, Model A1044U, P/N 268274

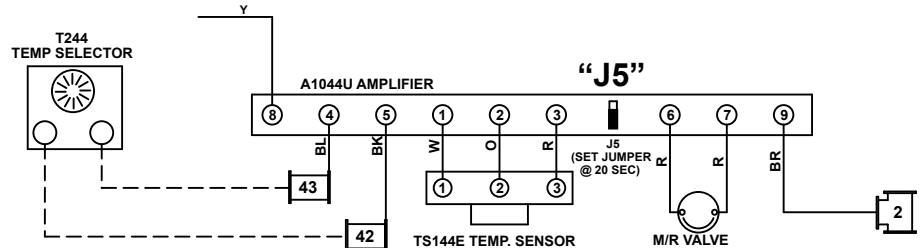

**Steps 4 & 5 apply to ALL Replacements - both Kit P/N 268301 and Kit P/N 268302**

4. When installation is complete, close the cabinet. Turn on the electric; turn on the gas; and check for proper operation.

5. Keep this form for future reference.

[www.ReznorHVAC.com](http://www.ReznorHVAC.com); (800) 695-1901

©2014 Reznor LLC, All rights reserved.

**Trademark Notes:** Reznor® is registered in at least the United States. All other trademarks are the property of their respective owners.

**REZNOR®**