

## Installation Instructions

**Applies to:   Optional Outside Air/Return Air  
 Mixing Box with Dampers  
 on Model CAUA**

### Description/ Application

The optional mixing box for the Model CAUA heater is designed to provide the system with a supply air mixture of return air and outside air. (**NOTE:** Application with a mixed air temperature below 35°F (2°C) requires that the CAUA unit be ordered with Option AD4.) The mixing box is available in an assortment of configurations with a selection of actuators and controls for both heating and cooling mode (for units equipped with a cooling coil). The mixing box is completely assembled at the factory for field attachment to the rear of a Model CAUA heater. It is recommended that the furnace be in its final location before attaching the mixing box.

All mixing box inlet air openings have duct flanges for attachment of ductwork. Removable door panels provide for filter access from either end of the cabinet. If the box was ordered with filters (Option AW9 or AW11), it is shipped with the filters installed. (For replacement filter sizes, see page 4.)

### Airflow Configurations

The optional mixing box is available in a variety of configurations to match the installation. The mixing box attaches to the rear of the heater and provides one of the airflow configurations described by option code (GA1-9) in the table on the right.

Option Code	Opening for Outside Air		Opening for Return Air	
	Location on Mixing Box	Includes Dampers	Location on Mixing Box	Includes Dampers
GA1	Top	Yes	Bottom or Rear	No
GA2	Rear	Yes	Top or Bottom	No
GA3	Bottom	Yes	Top or Rear	No
GA4	Bottom	Yes	Rear	Yes
GA5	Bottom	Yes	Top	Yes
GA6	Rear	Yes	Top	Yes
GA7	Rear	Yes	Bottom	Yes
GA8	Top	Yes	Rear	Yes
GA9	Top	Yes	Bottom	Yes

### Mixing Box Dimensions

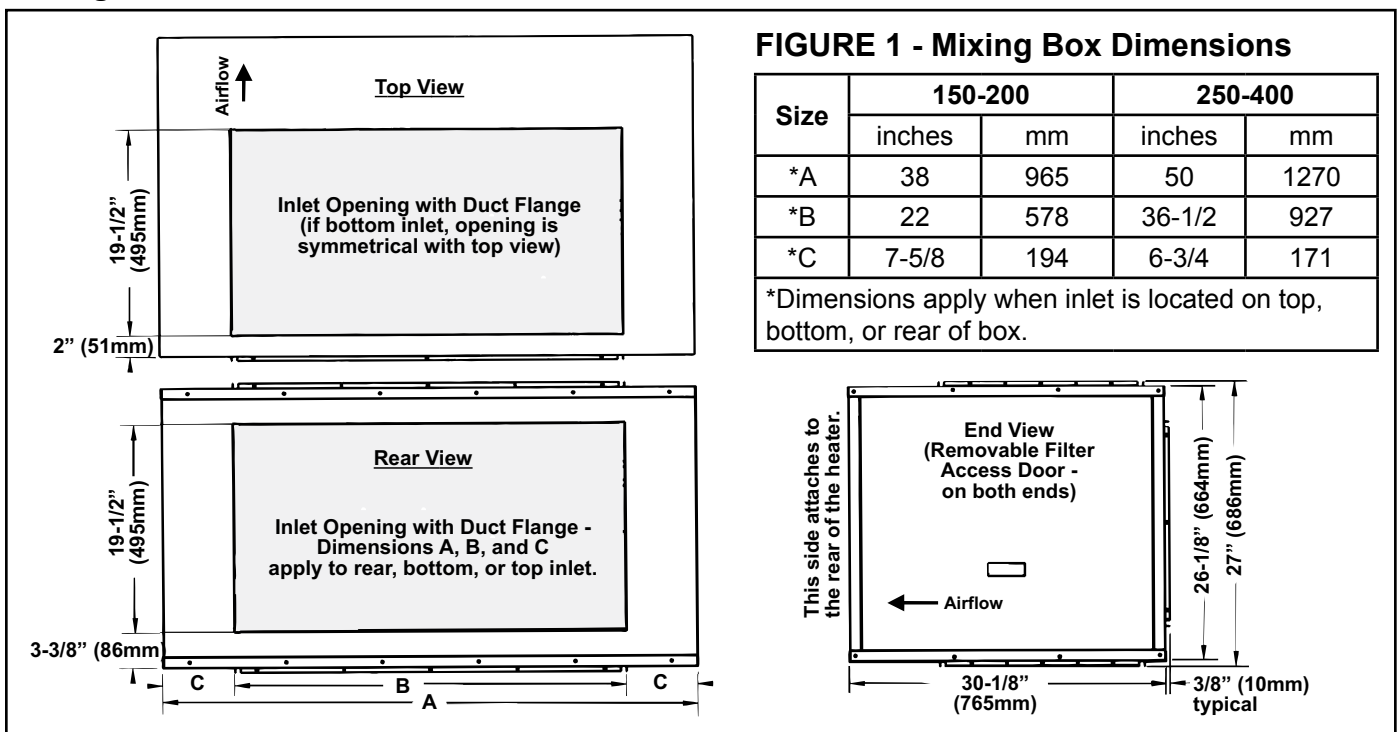

# Installation Instructions

Installation should be done by a qualified agency in accordance with the instructions in this manual and in compliance with all codes and requirements of authorities having jurisdiction. It is recommended that the heater be placed in its permanent location before attaching the mixing box.

## 1. Cut Out Air Inlet Opening (See FIGURE 2.)

On the rear of the heater where the mixing box cabinet is going to be attached, find four embosses in the metal panel. These embosses are corner indicators for the inlet air opening. Using tin snips or aviation shears, carefully cut straight lines between the corner marks until the opening is created.

**CAUTION: The cut edges of the metal cabinet will be sharp.**

**FIGURE 2 - Dimensions of inlet air opening to be cut out on rear of heater**

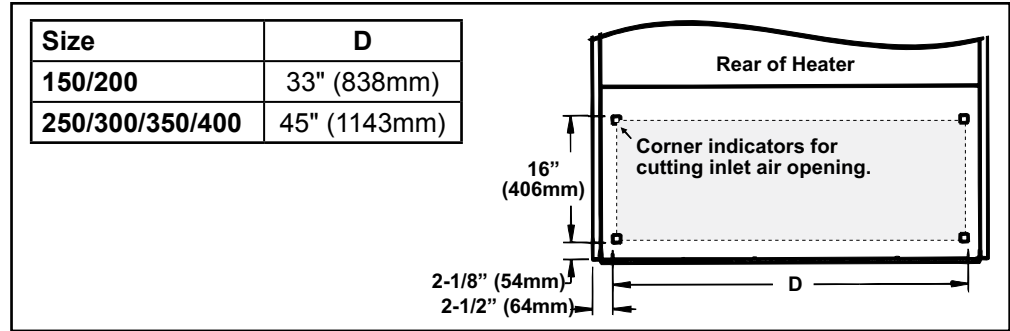

## 2. Drill Holes in the Heater Rear Panel (See FIGURE 3.)

On the rear of the heater, drill the 1/8" holes as illustrated.

**FIGURE 3 - Reference drawing for drilling 1/8" holes in the REAR of a Model CAUA heater when installing an optional mixing box**

CAUA Size	150-200	250-400	
A	inches	3	2-1/2
	mm	76	64
B	inches	8	9
	mm	203	229
C	No. of Holes	5	6

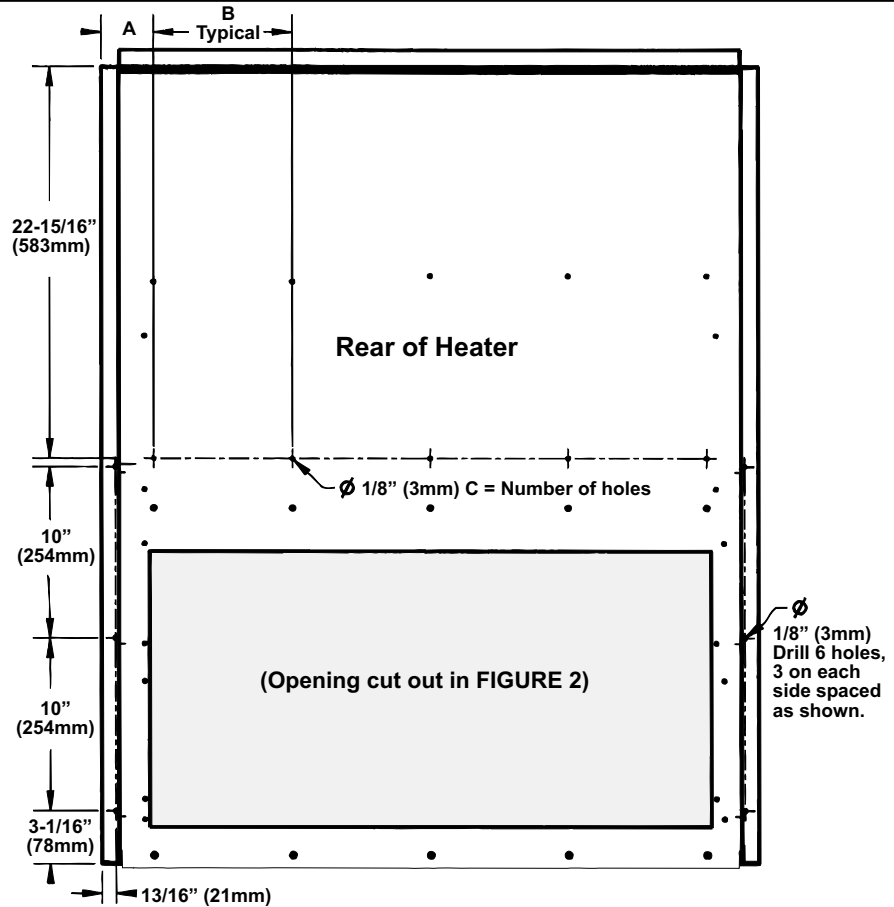

## 3. Select Return Air Location - Mixing Boxes with only Outside Air Dampers (no dampers in return air opening) - Opts GA1, GA2, GA3

The mixing box was manufactured with an outside air opening with dampers in either the top, rear, or bottom. There are two openings for return air allowing for a choice of location. When shipped, one return air opening is left open and the other covered.

Depending on the installation, the cover may be in the correct position or it may need to be moved. If the cover needs moved, remove the screws, position the cover over the return air opening that will not be used, and attach using the same screws.

**Installation NOTE:** Depending on which return air opening is being covered, you may want to wait to re-attach the cover after the mixing box is attached in Step 4.

#### 4. Attach the Mixing Box

On the rear of the heater, remove the row of screws along the bottom (save the screws). Position the mixing box against the rear of the heater. If installing a mixing box with two dampers, remove one or both access panels on the ends of the box. If only one damper, reach through the return air opening or remove end panel(s). Reaching inside the mixing box, replace the screws attaching the bottom edge of the mixing box to the heater.

Using the holes drilled in Step 2, attach both sides and across the top with the sheet-metal screws provided.

#### 5. Adjust the Damper Linkage - Applies to Mixing Boxes with *both* Outside & Return Air Dampers (GA4, GA5, GA6, GA7, GA8, GA9)

Both dampers are closed for shipping. The linkage for the return air damper must be adjusted prior to use. Follow instructions to adjust damper linkage.

- 1) Remove the access panel on the end of the mixing box where the damper controls are located.
- 2) Loosen the setscrew on the return air damper rod at the damper arm.
- 3) Manually open the return air dampers. While the dampers are opening, the damper rod and arm will automatically move to its correct position.
- 4) Tighten the setscrew.
- 5) Replace the end panel.

#### 6. Connect the Damper Motor Wires

Wiring depends on the motor and control options selected. See explanation of damper controls on page 4.

##### Wiring Instructions:

- 1) Remove the door panel on the front of the heater. Run the wires from the damper motor into the heater cabinet, up past the side of the burner box (the same side as the blower motor wires), and into the control compartment.
- 2) Refer to the wiring diagram with the heater and attach the wires to the terminals indicated.
- 3) Replace the heater door panel.

7. Installation of the optional mixing box is complete. Follow the instructions in the heater installation manual to complete the installation of your heater.

Attach the outside air ductwork to the duct flange on the outside air inlet of the mixing box. If the system includes return air ductwork, attach it to the duct flange on the return air inlet. To reduce noise transmission, use of a flexible duct boot to attach ductwork is recommended. Ductwork must be supported; do not rely on the mixing box to support the ductwork.

On startup, check for proper operation of the damper motor and controls.

### Damper Controls -

In all cases when the unit shuts down, the outside air damper closes.

Option	Description
<b>Damper Motors (Actuators)</b>	
<b>GB2</b>	2-position damper motor
<b>GB3</b>	Modulating damper motor
<b>GB4</b>	Modulating damper motor for use with proportional enthalpy control only
<b>Control Options (Cause motor to operate damper.)</b>	
<b>GC1A</b>	Potentiometer on mixing box
<b>GC1B</b>	Remotely located potentiometer
<b>GC3A</b>	Mixed air temperature controller, heating only
<b>GC3B</b>	Dual setpoint modulating enthalpy control for heating & cooling, w/GB4 only
<b>GC3C</b>	2-position enthalpy control to use w/2-position damper motor, cooling only
<b>GC4</b>	Senses return air temperature to delay opening of outside air damper providing warm up or cool down time

**IMPORTANT NOTE:** The standard Model CAUA is designed for a maximum temperature rise of 75°F. Above 35°F (2°C) outside air temperature, any percentage of outside air is permitted. For optimum operation and to prevent condensation, the mixed air temperature going to the heat exchanger must not be below 35°F (2°C).

This inlet air temperature restriction does not apply to a Model CAUA ordered with makeup air Option AD4. A CAUA unit equipped with makeup air Option AD4 includes stainless steel components and a flue wrapper condensate drain to permit inlet air temperature below 35°F (2°C).

Mixing Box	Motor	Control	Description	Operating Mode	Application (NOTE: Cooling mode requires optional cased cooling coil.)
Option Code(s)					
GA1, GA2, GA3, GA4, GA5, GA6, GA7, GA8, GA9.	GB2	None	2-Position Damper Motor	Heating only or Heating & Cooling	When the unit is operating, the outside air damper is open.
		GC3C	2-Position Damper Motor with 2-Position Enthalpy Control	Cooling only	To minimize cooling energy consumption and equipment cycling, when the sensor detects a low enthalpy (heat content in a lb of air) in the outside air, the control will open the outside air damper. When the control senses a high enthalpy in the outside air, it will close the outside air damper. Factory setpoint for opening the outside air damper is 75°F/40% humidity.
		GC3C & GC4			Same as above (GC3C only) plus a delay based on return air temperature. Control delays the opening of the outside air damper to provide faster cool down of supply air.
GA4, GA5, GA6, GA7, GA8, GA9.	GB3	GC1A or GC1B	Modulating Damper Motor with Manual Potentiometer Mounted in the Mixing Box (GC1A) or Remote (GC1B)	Heating only or Heating and Cooling	To control mixture of inlet air, manually set the potentiometer to the desired minimum position of the outside air damper. (See <b>IMPORTANT NOTE</b> above.)
		GC1A or GC1B w/ GC3A			Same as above (GC1A or GC1B only) plus in heating mode the dampers are modulated in response to a control sensing the mixed inlet air temperature. Adjustable control has a range of 0-100°F; factory setpoint is 35°F. See <b>IMPORTANT NOTE</b> above.
		GC1A or GC1B w/ GC4			Same as above (GC1A or GC1B only) plus a delay based on return air temperature. Control delays the opening of the outside air damper to provide faster cool down (cooling mode) or warm up (heating mode) of supply air.
		GC1A or GC1B w/ both GC3A & GC4			Includes all of the control functions listed in this section - a potentiometer (GC1A or GC1B) with both the mixed air controller (GC3A) and the delay (GC4).
	GC3A	Modulating Damper Motor with Mixed Air Controller	Heating only	Dampers are modulated in response to a control sensing the mixed inlet air temperature. The adjustable control has a range of 0-100°F; factory setpoint is 35°F. See <b>IMPORTANT NOTE</b> above.	
				Above plus a delay based on return air temperature. Control delays the opening of the outside air damper to provide faster warm up of supply air.	
	GB4	GC3B	Modulating Damper Motor with a Logic Module and Dual Setpoint Modulating Enthalpy Control	Cooling and Heating	In cooling mode, damper modulation is controlled by a modulating enthalpy control. With one sensor measuring the enthalpy of the outside air and another sensing the return air, dampers will modulate in response to the control to maintain the most economic mix in the inlet air (normally set to maintain between 50-56°F). With two enthalpy setpoints, damper operation can be interlocked with a time clock or other device to provide different mix depending on occupancy or other determining factor. In the heating mode, damper modulation is controlled by a mixed air temperature sensor. (See <b>IMPORTANT NOTE</b> above.)
Above (GC3B only) plus a delay based on return air temperature. Control delays the opening of the outside air damper to provide faster cool down (cooling mode) or warm up (heating mode) of the supply air.					

## Replacement Filters

CAUA Size	2" Pleated, Disposable			2" Pleated, Aluminum		
	Qty	Size	P/N	Qty	Size	P/N
150 - 200	2	16x16	104109	2	16x16	104103
	2	16x20	104110	2	16x20	101620
250 - 400	6	16x16	104109	6	16x16	104103

Specifications & illustrations subject to change without notice and without incurring obligations.

© Nortek Global HVAC LLC 2015. All rights reserved.

All trademarks are the property of their respective owners.

Printed in the U.S.A. (04/15)

Form I-CAUA-MB (04-15)