

INSTALLATION / OPERATION / MAINTENANCE

Applies to: **Model SSCBL
and Model RPBL
Packaged Systems**



**Indoor,
Separated-Combustion
Model SSCBL**



**Outdoor, Power Vented
Model RPBL**

WARNING:

FIRE OR EXPLOSION HAZARD

Failure to follow safety warnings exactly could result in serious injury, death, or property damage.

Be sure to read and understand the installation, operation, and service instructions in this manual.

Improper installation, adjustment, alteration, service, or maintenance can cause serious injury, death, or property damage.

- Do not store or use gasoline or other flammable vapors and liquids in the vicinity of this or any other appliance.
- **WHAT TO DO IF YOU SMELL GAS**
 - Do not try to light any appliance.
 - Do not touch any electrical switch; do not use any phone in your building.
 - Leave the building immediately.
 - Immediately call your gas supplier from a phone remote from the building. Follow the gas supplier's instructions.
 - If you cannot reach your gas supplier, call the fire department.
- Installation and service must be performed by a qualified installer, service agency, or the gas supplier.

Table of Contents

<p>1.0 General2</p> <p> 1.1 Hazard Labels and Notices2</p> <p> 1.2 General Installation Information3</p> <p> 1.3 Warranty.....3</p> <p> 1.4 Installation Codes3</p> <p>2.0 Furnace Location.....3</p> <p>3.0 Uncrating and Preparation.....4</p> <p> 3.1 Uncrating and Inspecting4</p> <p> 3.2 Preparing for Installation.....4</p> <p>4.0 Dimensions and Clearances5</p> <p> 4.1 Dimensions5</p> <p> 4.2 Clearances8</p> <p>5.0 Suspension and Mounting.....8</p> <p> 5.1 Weights8</p> <p> 5.2 Suspension - Model SSCBL.....8</p> <p> 5.3 Indoor Mounting on Field-Supplied Supports8</p> <p> 5.4 Mounting Outdoor Model RPBL.....9</p> <p>6.0 Mechanical13</p> <p> 6.1 Gas Piping and Pressures.....13</p> <p> 6.2 Venting and Combustion Air15</p> <p> 6.3 Unit Inlet Air26</p> <p> 6.4 Duct Connections - SSCBL and RPBL.....38</p> <p> 6.5 Blowers, Belts, and Drives39</p> <p>7.0 Electrical Supply and Controls.....41</p> <p> 7.1 General.....41</p>	<p> 7.2 Supply Voltage and Wiring41</p> <p> 7.3 Thermostat and Control Wiring42</p> <p>8.0 Controls43</p> <p> 8.1 Control Locations43</p> <p> 8.2 Fan Control43</p> <p> 8.3 High Temperature Limits44</p> <p> 8.4 Optional Airflow Proving Switch (Makeup Air)44</p> <p> 8.5 Reverse Flow, Limit Control44</p> <p> 8.6 Optional High Ambient Limit Control.....44</p> <p> 8.7 Combustion Air Proving Switch44</p> <p> 8.8 Gas Controls.....44</p> <p> 8.9 Pilot and Ignition Systems51</p> <p> 8.10 Burners, Orifices, and Carryover System.....51</p> <p> 8.11 Burner Air Shutters52</p> <p>9.0 Check Installation and Start-Up52</p> <p> 9.1 Check the installation prior to start-up:.....52</p> <p> 9.2 Start-Up53</p> <p> 9.3 Check installation after Start-up:.....53</p> <p>10.0 Maintenance and Service.....54</p> <p> 10.1 Maintenance Schedule54</p> <p> 10.2 Maintenance Procedures.....54</p> <p> 10.3 Troubleshooting57</p> <p>INDEX.....59</p> <p>INSTALLATION RECORD - to be completed by the installer:60</p>
---	---

1.0 General

1.1 Hazard Labels and Notices

There are warning labels on the unit and throughout this manual. For your safety, read the definitions below and comply with all boxes labeled CAUTION, WARNING, and DANGER during installation, operation, maintenance, and service of this heater.

Definitions of HAZARD INTENSITY LEVELS used in this Manual

1. **DANGER:** Failure to comply will result in severe personal injury or death and/or property damage.
2. **WARNING:** Failure to comply could result in severe personal injury or death and/or property damage.
3. **CAUTION:** Failure to comply could result in minor personal injury and/or property damage.

WARNING

Gas-fired appliances are not designed for use in hazardous atmospheres containing flammable vapors or combustible dust, in atmospheres containing chlorinated or halogenated hydrocarbons, or in applications with airborne silicone substances. See Hazard Levels, above.

WARNING

Improper installation, adjustment, alteration, service, or maintenance can cause property damage, injury or death. Read the installation, operation, and maintenance instructions thoroughly before installing or servicing this equipment.

WARNING

To ensure safety, follow lighting instructions located on the outlet box cover. See Hazard Levels, above.

1.2 General Installation Information

1.3 Warranty

Installation should be done by a qualified agency in accordance with the instructions in this manual and in compliance with all codes and requirements of authorities having jurisdiction. The instructions in this manual apply to Model SSCBL and Model RPBL.

Refer to the limited warranty form in the "Literature Bag".

WARRANTY: Warranty is void if.....

- a. Furnaces are used in atmospheres containing flammable vapors or atmospheres containing chlorinated or halogenated hydrocarbons or any contaminant (silicone, aluminium oxide, etc.) that adheres to the spark ignition flame sensing probe.**
 - b. Wiring is not in accordance with the diagram furnished with the heater.**
 - c. Unit is installed without proper clearances to combustible materials.**
 - d. Furnace air throughput is not adjusted within the range specified on the rating plate.**
-

1.4 Installation Codes

The packaged systems in this manual include duct furnace(s) that are design-certified to ANSI and CSA standards by the Canadian Standards Association. The duct furnaces are approved for installation in the United States and in Canada. All furnaces are approved for use with either natural gas or propane. The type of gas for which the furnace is equipped and the correct firing rate are shown on the rating plate attached to the unit. Electrical characteristics are shown on the unit rating plate.

These units must be installed in accordance with local building codes. In the absence of local codes, in the United States, the unit must be installed in accordance with the National Fuel Gas Code NFPA/ANSI Z223.1 (latest edition). A Canadian installation must be in accordance with the CSA B149.1 Natural Gas and Propane Installation Code. These codes are available from CSA Information Services, 1-800-463-6727. Local authorities having jurisdiction should be consulted before installation is made to verify local codes and installation procedure requirements.

The separated-combustion furnaces in Model SSCBL are designed and manufactured in accordance with the ANSI definition of separated combustion. That definition reads, "Separated Combustion System Appliance: A system consisting of an appliance and a vent cap(s) supplied by the manufacturer, and (1) combustion air connections between the appliance and the outside atmosphere, and (2) flue gas connections between the appliance and vent cap, of a type(s) specified by the manufacturer but supplied by the installer, constructed so that, when installed in accordance with the manufacturer's instructions, air for combustion is obtained from the outside atmosphere and flue gases are discharged to the outside atmosphere." Separated combustion units are designed to separate air for combustion and flue products from the environment of the building in which the unit is installed. Separated combustion appliances are recommended for use in dust laden and some corrosive fume environments.

Installations in aircraft hangars should be in accordance with NFPA No. 409 (latest edition), Standard for Aircraft Hangars; in public garages in accordance with NFPA No. 88A (latest edition), Standard for Parking Structures; and for repair garages in accordance with NFPA No. 88B (latest edition), Standard for Repair Garages. In Canada, installations in aircraft hangars, repair garages, and parking garages should be in accordance with the requirements of the enforcing authorities and in accordance with CSA B149 codes.

Special Installations (Aircraft Hangars/ Garages)

All Installations

These gas-fired products are certified by ANSI Z83 family of standards governing the safe usage of heating equipment in the industrial/commercial marketplace. This includes using the heaters in makeup air applications to supply corridor pressurization in commercial buildings such as office structures and apartment complexes.

The heaters are not certified as residential heating equipment and should not be used as such.

2.0 Furnace Location

Clearances from the heater and vent to combustible construction or material in storage must conform with the National Fuel Gas Code ANSI Z223.1a (latest edition) pertaining to gas-burning devices, and such material must not attain a temperature over 160°F by continued operation of the heater.

2.0 Furnace Location (cont'd)

Location must comply with the clearances listed in Paragraph 4.2. There are a variety of factors, such as system application, building structure, dimensions, and weight, that contribute to selecting the location. Read the installation information in this manual and select a location that complies with the requirements.

CAUTION: Do not locate an indoor Model SSCBL where it may be exposed to water spray, rain, or dripping water.

Package Configurations

FIGURE 1 - Package Arrangements by Model and Size

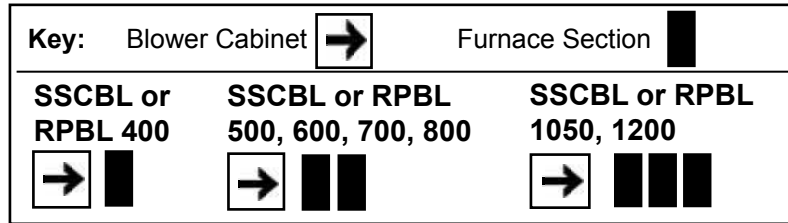

Hazards of Chlorine

The presence of chlorine vapors in the combustion air of gas-fired heating equipment presents a potential corrosion hazard. Chlorine will, when exposed to flame, precipitate from the compound, usually freon or degreaser vapors, and go into solution with any condensation that is present in the heat exchanger or associated parts. The result is hydrochloric acid which readily attacks all metals including 300 grade stainless steel. Care should be taken to separate these vapors from the combustion process. This may be done by wise location of the furnace with regard to exhausters or prevailing wind direction. Remember, chlorine is heavier than air. This fact should be kept in mind when determining installation locations of heating equipment and building exhaust systems.

3.0 Uncrating and Preparation

3.1 Uncrating and Inspecting

This furnace was test operated and inspected at the factory prior to crating and was in operating condition. If the equipment has incurred any damage in shipment, document the damage with the transporting agency and immediately contact an authorized Reznor® distributor. If you are an authorized Distributor, follow the FOB freight policy procedures as published by Reznor for Reznor® products.

Check the rating plate for the gas specifications of the furnace and electrical characteristics of the unit to be sure that they are compatible with the gas and electric supplies at the installation site.

Shipped-Separate Components

Read this booklet and become familiar with the installation requirements of your particular furnace. If you do not have knowledge of local requirements, check with the local gas company or any other local agencies who might have requirements concerning this installation. Before beginning, make preparations for necessary supplies, tools, and manpower.

Options - Some gas control options have parts either shipped loose with the heater or shipped separately. If your unit is equipped with any of the following gas control options, be sure these parts are available at the job site.

Controls	Option AG	Shipped-Separate Components
Heating Gas Control Options	7	Thermostat, P/N 48033
	10	Thermostat, P/N 91919
	11	Thermostat, P/N 93435
Makeup Air Gas Control Options (If an optional remote console is ordered, the control switch is mounted on the console.)	3, 8	Control Switch, P/N 29054
	9	Remote Temperature Selector, P/N 48042 Control Switch, P/N 29054
	15	Remote Temperature Selector, P/N 115848 Stage-Adder Module, P/N 115849 (one furnace - 1; two furnaces - 3; three furnaces - 5) Control Switch, P/N 29054
	17, 19	Remote Temperature Selector, P/N 115848 Stage-Adder Module, P/N 115849 (two furnaces - 1; three furnaces - 2) Control Switch, P/N 29054
	18, 20	Remote Temperature Selector, P/N 115848 Stage-Adder Module, P/N 115849 (two furnaces - 1; three furnaces - 2) Remote Display Module, P/N 115852 Control Switch, P/N 29054
	39, 41	Remote Temperature Selector, P/N 174849

Other shipped-separate options could include a roof curb, an outside air hood, a gas shutoff valve, a thermostat, an optional control switch, a remote console, a vent extension, a gas supply regulator, and/or a disconnect switch. If ordered with either an evaporative cooling module or a DX or chilled water cooling coil module, the module is shipped separately. A drain and fill or freeze kit and a water hammer arrestor are shipped-separate options for an evaporative cooling module.

Vent/Combustion Air Terminal Kit - Required on ALL SSCBL Installations

All Model SSCBL installations require a vent/combustion air kit (Option CC2 or CC6) including a concentric adapter box for each duct furnace. See page 19 (Option CC6) or page 22 (Option CC2) for the component list of each kit. Be sure all of the factory-supplied and field-supplied parts needed for the vent/combustion air kit(s) are at the job site.

4.0 Dimensions and Clearances

4.1 Dimensions

4.1.1 Dimensions of Indoor Model SSCBL

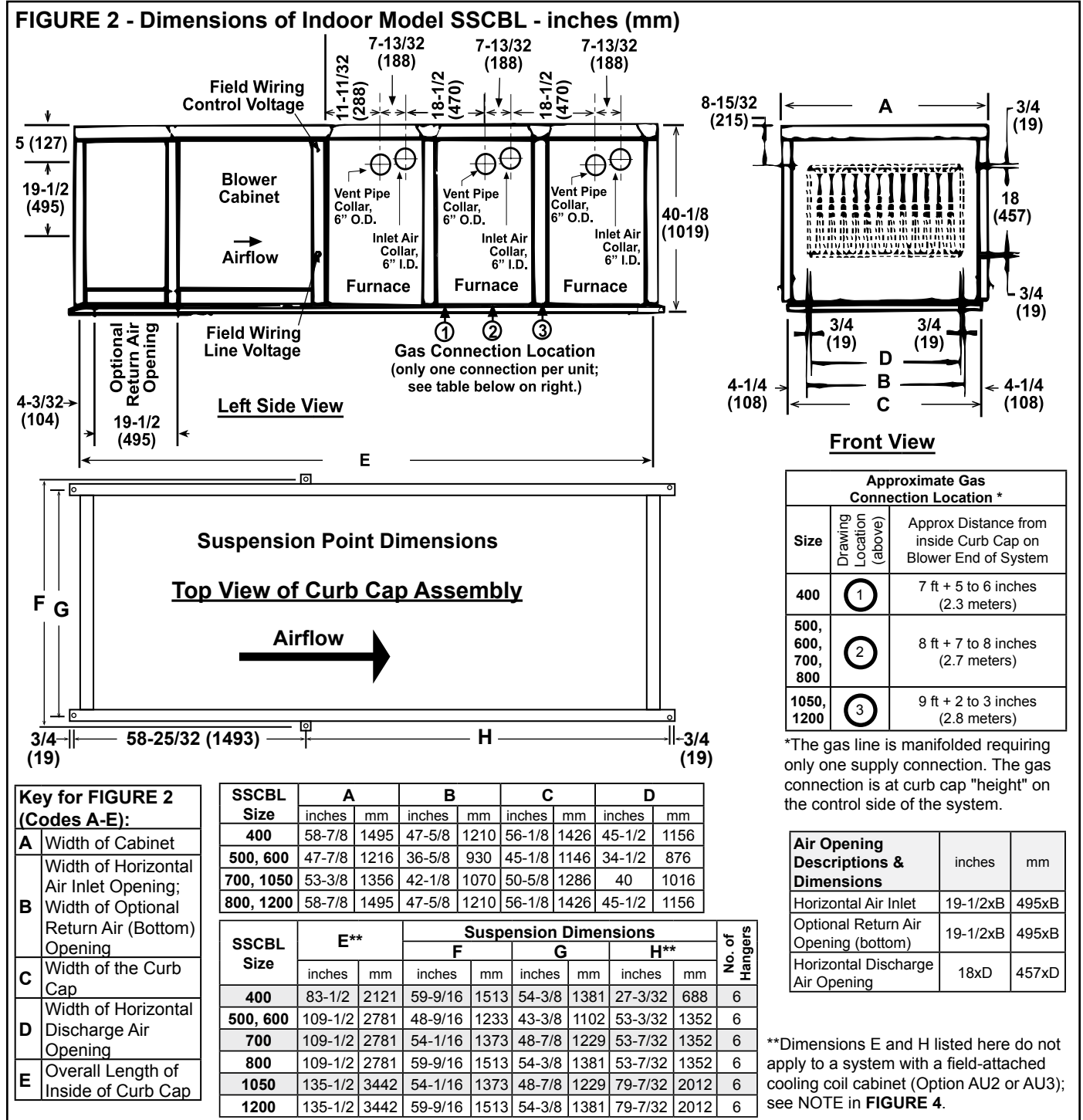

4.0 Dimensions and Clearances (cont'd)

4.1 Dimensions (cont'd)

4.1.2 Dimensions of Outdoor Model RPBL

FIGURE 3 - Dimensions of Outdoor Model RPBL - inches (mm)

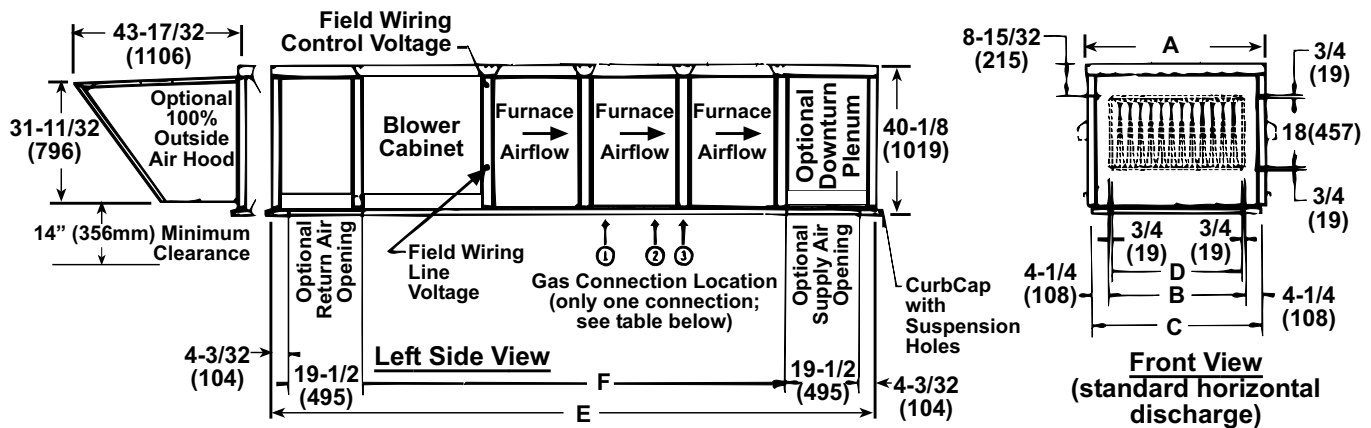

Dimension Key:

A	Width of Cabinet	D	Width of Standard Horizontal Discharge Air Opening
B	Width of Optional Downturn Plenum Discharge Air Opening; Width of Standard Horizontal Air Inlet Opening; and Width of Optional Return Air (Bottom) Opening	E	Overall Length of Inside of Curb Cap
C	Width of the Curb Cap	F	Distance between Optional Return Air Bottom Opening and Optional Downturn Plenum Discharge Air Opening

Model	Size		A	B	C	D
RPBL	500, 600	inches	47-1/8	36-5/8	45-1/8	34-1/2
		mm	1216	930	1146	876
	700, 1050	inches	53-3/8	42-1/8	50-5/8	40
		mm	1356	1070	1286	1016
	400, 800, 1200	inches	58-7/8	47-5/8	56-1/8	45-1/2
		mm	1495	1210	1426	1156

Air Openings:		inches	mm
Standard Horizontal Air Inlet		19-1/2 x B	495 x B
Optional Return Air Opening (bottom)		19-1/2 x B	495 x B
Standard Horizontal Discharge Air Opening		18 x E	457 x D
Opt Discharge Air Opening (w/Downturn Plenum)		19-1/2 x B	495 x D

Approximate Gas Connection Location*			
Size	Drawing Location	Approximate Distance from inside Curb Cap on Blower End of System	
400	①	7 ft + 5 to 6 inches (2.3 meters)	The gas line is manifolded requiring only one supply connection.
500, 600, 700, 800	②	8 ft + 7 to 8 inches (2.7 meters)	The gas connection is at curb cap
1050, 1200	③	9 ft + 2 to 3 inches (2.8 meters)	"height" on the control side of the system.

Model	Size	with Downturn Opt AQ5 or AQ8*	E**		F**	
			inches	mm	inches	mm
RPBL	400	No	83-3/4	2127	--	
		Yes	107-3/4	2737	60-5/16	1532
	500, 600, 700, 800	No	109-3/4	2788	--	
		Yes	133-3/4	3397	86-5/16	2192
	1050, 1200	No	135-3/4	3448	--	
		Yes	159-3/4	4058	112-5/16	2853

*The gas line is manifolded requiring only one supply connection; see more detail in Paragraph 6.1. The gas connection is at curb cap "height" on the control side of the system.

**Dimensions E and F listed here do not apply to system with field-attached cooling coil cabinet or cooling coil cabinet with downturn plenum (Options AU2, AU3, AU11, AU12, AU13, and AU14). See NOTE in FIGURE 4.

4.1.3 Dimensions - Optional Cooling Coil Cabinet

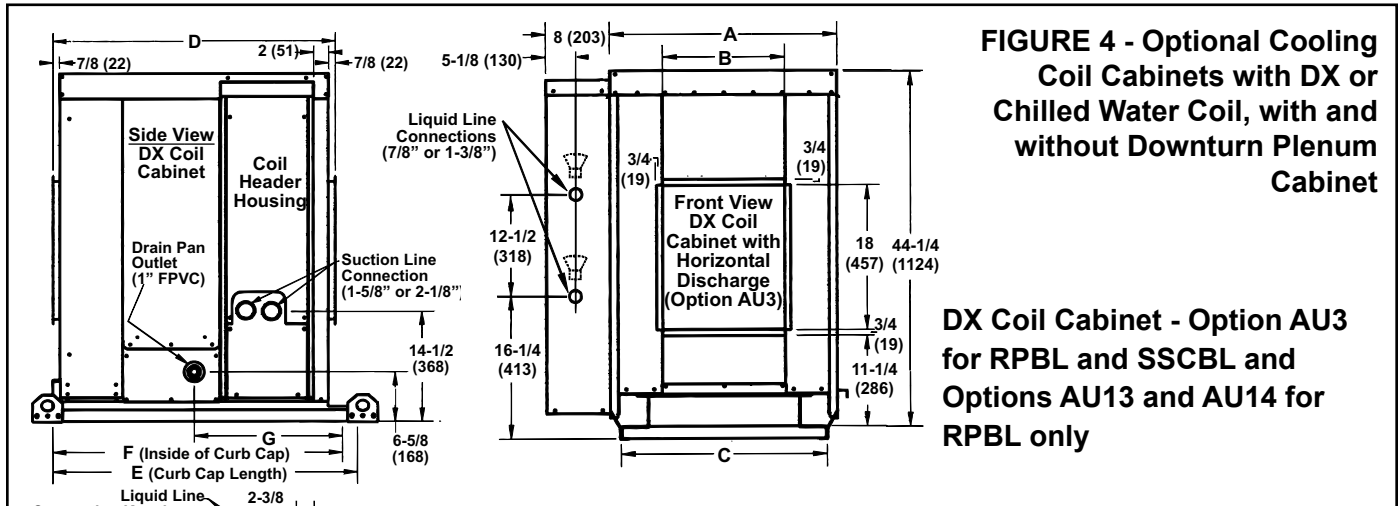
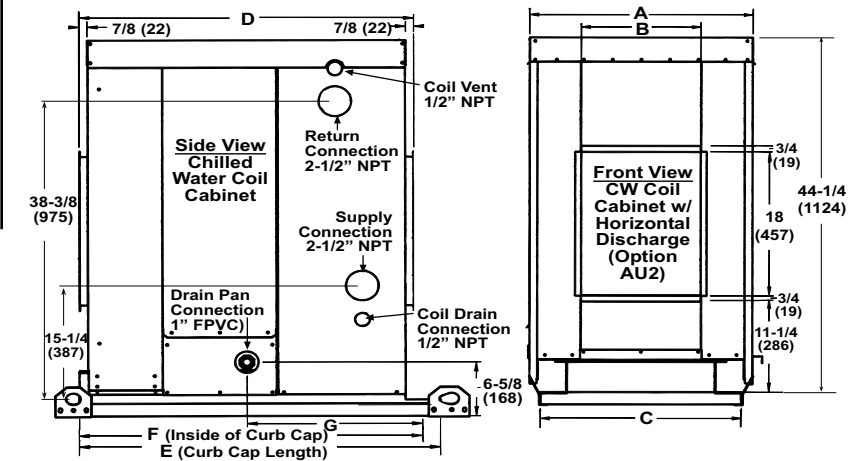

FIGURE 4 - Optional Cooling Coil Cabinets with DX or Chilled Water Coil, with and without Downturn Plenum Cabinet

DX Coil Cabinet - Option AU3 for RPBL and SSCBL and Options AU13 and AU14 for RPBL only

Chilled Water Coil Cabinet - Option AU2 for RPBL and SSCBL and Options AU11 and AU12 for RPBL only



Dimensions (all AU coil cabinets)

SSCBL or RPBL Size		500, 600	700, 1050	400, 800, 1200
A	inches	47-3/4	53-1/4	58-3/4
	mm	1213	1353	1492
B	inches	34-1/2	40	45-1/2
	mm	876	1016	1156
C	inches	45-1/8	50-5/8	56-1/8
	mm	1146	1286	1426
D	inches	56-3/8	62	67-3/8
	mm	1432	1575	1711
E	Without Downturn	inches 59-3/8	64-7/8	70-3/8
	mm 1508	1648	1788	
E	With Downturn	inches 83-3/8	88-7/8	94-3/8
	mm 2118	2257	2397	
F	Without Downturn	inches 57-3/8	63	68-3/8
	mm 1457	1600	1737	
F	With Downturn	inches 81-3/8	87	92-3/8
	mm 2067	2210	2346	
G	inches	29-1/8	31-7/8	34-5/8
	mm	740	810	879
H	inches	45-1/8	50-5/8	56-1/8
	mm	1146	1286	1426

Downturn Plenum Cabinet (factory attached)

Discharge Damper Note: Optional two-position discharge dampers in Option AU12 or AU14 fit in the discharge air opening. The damper motor fits inside the downturn cabinet. See field wiring instructions in Paragraph 6.3.6.

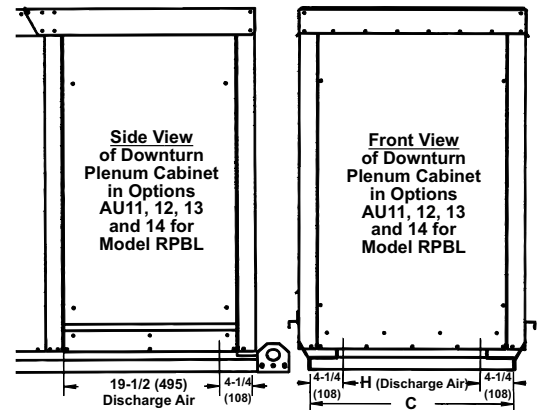

NOTE: For the length of a Model RPBL with a cooling coil cabinet, see the table on the right. Cooling coil cabinet is shipped separately and attached in the field. See page 11 for roof curb dimensions. Total length of an indoor system with a cooling coil cabinet depends on how the system is installed. If the blower/furnace is suspended, a special curb cap and a field-installed transition duct are required. Contact your Sales Representative to receive specific information. If an indoor system is mounted, add the cabinet length to the blower/furnace length on page 5.

RPBL Size	Width of Cabinet (not curb)				Length of Cabinet (not curb)			
	w/Chilled Water Coil Cabinet		w/DX Coil Cabinet		w/Cooling Coil Cabinet only		w/Cooling Coil Cabinet w/Downturn	
	inches	mm	inches	mm	inches	mm	inches	mm
400	58-7/8	1495	66-7/8	1698	150-3/8	3820	173-1/2	4407
500, 600	47-1/8	1197	55-1/8	1400	165-3/8	4201	188-1/2	4788
700	53-3/8	1356	61-3/8	1559	171	4343	194-1/8	4931
800	58-7/8	1495	66-7/8	1698	176-3/8	4480	199-1/2	5067
1050	53-3/8	1356	61-3/8	1559	197	5004	220-1/8	5591
1200	58-7/8	1495	66-7/8	1698	202-3/8	5140	225-1/2	5728

4.0 Dimensions and Clearances (cont'd)

4.2 Clearances

For safety and convenience, provide clearances as shown in the table. Clearance to combustibles is defined as the minimum distance from the heater to a surface or object that is necessary to ensure that a surface temperature of 90°F above the surrounding ambient temperature is not exceeded. Minimum clearances are also listed on the heater rating plate.

Required Clearances - inches (mm)	Model SSCBL	Side Opposite Controls - 6" (152mm) is required for clearance to combustibles. 30" (762mm) service clearance is recommended for access to the motor.
		Control Side (for service) - 56" (1422mm)
		Top - 6" (152mm)
	Model RPBL	Furnace Bottom - 6" (152mm)
		Control Side (for service) - 56" (1422mm)
		Side Opposite Controls - 30" (762mm) service clearance is recommended for access to the motor.
		*Furnace Bottom - 0" (0mm)

*When installed on a roof curb on a combustible roof, the roof area enclosed within the curb must be either ventilated, left open, or covered with non-combustible material which has an "R" value of at least 5.0. See **FIGURE 9A**, page 11.

5.0 Suspension and Mounting

5.1 Weights

Before installing, check the supporting structure to be sure that it has sufficient load-carrying capacity to support the weight of the unit. Properly suspending or mounting the unit is the responsibility of the installer. Model SSCBL systems are designed for either suspension or mounting. Model RPBL systems are designed for mounting only. All installed systems must be level.

Model and Size	Net Weight (lbs and kg)							
	400	500	600	700	800	1050	1200	
SSCBL	lbs	849	1104	1104	1184	1245	1476	1565
	kg	385	500	500	537	565	670	710
RPBL	lbs	849	1104	1104	1184	1245	1476	1565
	kg	385	500	500	537	565	670	710

5.2 Suspension - Model SSCBL

A Model SSCBL unit is equipped with a load-bearing curb cap which forms an integral part of the unit. The curb cap is welded at all joints and has suspension holes at each corner and hanger brackets on the sides. See **FIGURE 2** for suspension dimensions. Each suspension location requires a 1/2" threaded rod as illustrated in **FIGURE 5**.

FIGURE 5 - Support Rod Detail -

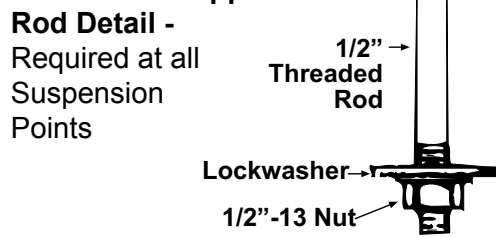

WARNING

Units must be supported level for proper operation. Do not place or add additional weight to the suspended unit. See Hazard Levels, page 2.

5.3 Indoor Mounting on Field-Supplied Supports - Model SSCBL

Prior to installation, be sure that the method of support is in agreement with all local building codes. Whether the supports are being mounted directly on a surface or being placed "up" on additional structure, the horizontal length of the system should be supported by two 4x4 treated wooden rails. Cut the rails to the appropriate length (Dimension "A" in **FIGURE 6A**).

Space the 4x4 wooden rails (See "B" Dimension, **FIGURE 6A**) so that the curb cap "skirt" will fit over the edge of the boards with the rails setting inside the horizontal length of the curb cap.

If the rails are being laid directly on a surface, position them as shown in **FIGURE 6B**. Set the system on the rails, leaving the "ends" underneath open for ventilation.

If the rails are not placed directly on a surface, cross-supports should be placed underneath the rails at the ends of the unit and at all cabinet "joints" (between the blower cabinet and the furnace section, between each furnace section, and between the furnace and an optional downturn plenum cabinet). See **FIGURE 6B**. The field-supplied, cross-support structure must be adequate for the weight of the unit. Cross-supports should run the entire width of the unit, supporting the 4x4 wooden rails at all recommended locations.

FIGURE 6A - Mounting Support Dimensions - inches (mm)

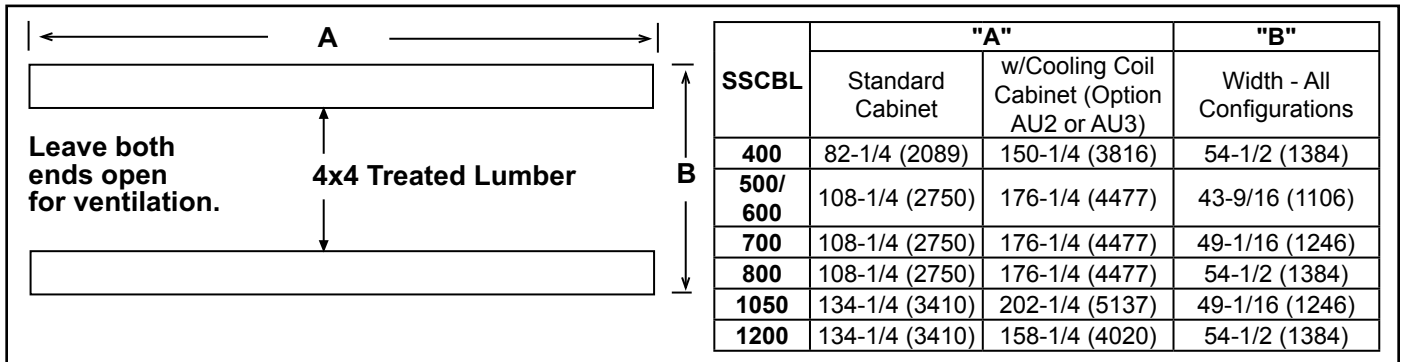
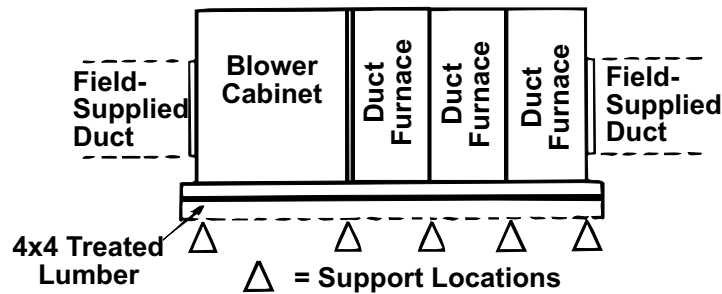

FIGURE 6B - Cross Support Locations



5.4 Mounting Outdoor Model RPBL

5.4.2 Base Construction

5.4.3 Mounting Outdoor Models on Field-Supplied Supports (without a roof curb) - Applies to Model RPBL

Prior to installation, be sure

5.4.1 Rigging

Lifting holes are provided for rigging. Use spreader bars when lifting to prevent chains or cables from damaging the unit. If the unit is being mounted on a roof curb, apply caulking to the roof curb prior to lifting the unit to the roof and setting it on the curb. See **FIGURE 9A**, page 11. If the system includes an outside air hood, a cooling coil cabinet, or an evaporative cooling module, attach them *after* the system is in place.

Curb Cap Base - A Model RPBL unit is equipped with a load-bearing curb cap which forms an integral part of the unit. This curb cap is welded at all joints and has a "skirt" which fits over a roof curb to provide a weatherproof installation. Holes are provided at the curb cap corners for lifting the unit. These holes do not interfere with unit weatherproofing. **The curb cap is not designed to be placed directly on the roof surface.** The system may be mounted on an optional roof curb purchased with the unit, a field-supplied roof curb, or field-supplied supports. If the system has a downturn plenum and/or a bottom return air opening, a roof curb is recommended to provide a weatherproof installation as well as more workable clearances for ductwork.

that the method of support is in agreement with all local building codes and is suited to the climate. If considering this type of installation in snow areas, it is recommended that the 4x4 wooden rails underneath the system be on cross-support structure at least 12" higher than the roof surface (see cross support locations in **FIGURE 8**, page 10).

Whether the supports are being mounted directly on the roof or being placed "up" on additional structure, the horizontal length of the system should be supported by two 4x4 treated wooden rails. Cut the rails to the appropriate length (Dimension "A") in **FIGURE 7**. (**NOTE:** Although dimensions are included for units with a downturn plenum cabinet, it is strongly recommended that a full roof curb be used on an installation with a downturn plenum cabinet and/or a bottom return air duct.)

Space the 4x4 wooden rails (See "B" Dimension, **FIGURE 7**) so that the curb cap "skirt" will fit over the edge of the boards with the rails setting inside the horizontal length of the curb cap.

5.0 Suspension and Mounting (cont'd)

5.4 Mounting Outdoor Model RPBL (cont'd)

5.4.3 Mounting Outdoor Models on Field-Supplied Supports (without a roof curb) - Applies to Model RPBL (cont'd)

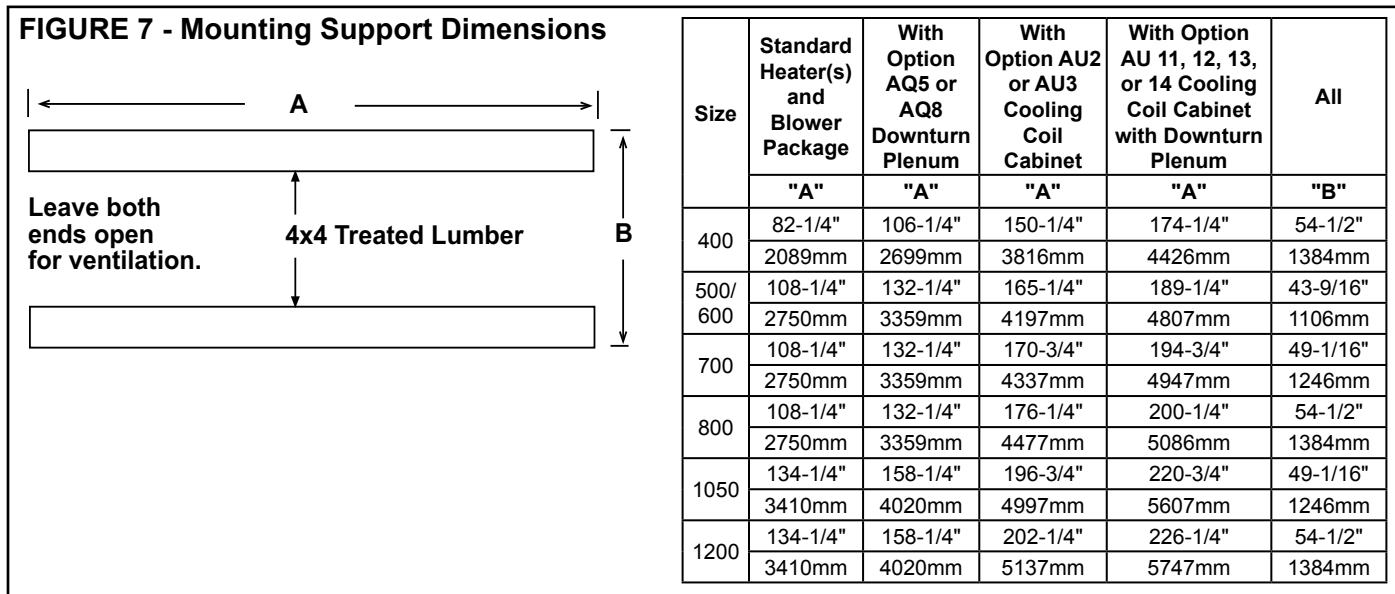

If the rails are being laid directly on the roof, position them as shown in **FIGURE 7**. Set the system on the rails, leaving the "ends" underneath open for ventilation.

If the treated wooden rails are not being placed directly on the roof surface, cross-supports should be placed underneath the rails at the ends of the unit and at all cabinet "joints" (between the blower cabinet and the heater section and between the furnace and the optional downturn plenum cabinet). See **FIGURE 8**.

The field-supplied, weather-resistant cross-support structure must be adequate for the weight of the system, and all cross-supports should run the entire width of the system supporting the 4x4 wooden rails at the recommended locations. Do not enclose the area under the furnace; leave space for ventilation.

WARNING

Do not close or block the openings under each end of a system mounted on 4x4 treated wooden rails; the space under the furnace MUST be left open for ventilation.

If cross supports are used under the 4x4 rails, do not enclose the area under the furnace; leave open space for ventilation.

FIGURE 8 - Cross-Support Locations for Outdoor Systems when the wooden 4x4 rails supporting the length of the system are supported by additional structure

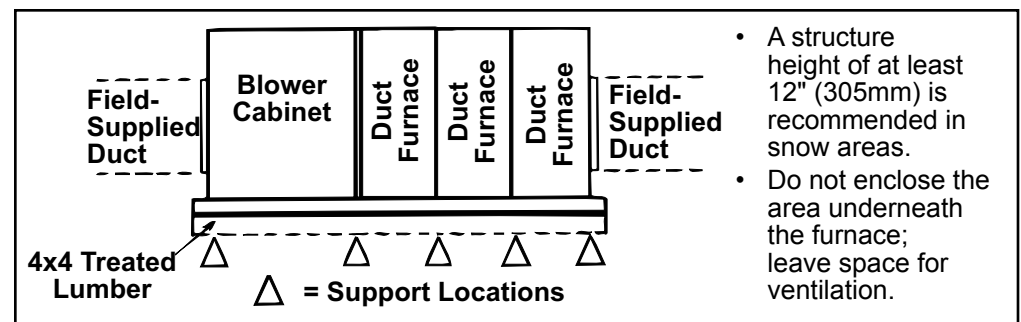

5.4.4 Mounting on a Roof Curb - Applies to Outdoor Model RPBL

Whether using an optional roof curb supplied with the system or a field-supplied curb, the curb must be secure, square and level. The top surface of the roof curb must be caulked with 1/4" x 1-1/4" sealant tape or two 1/4" beads of suitable sealant. The unit must be sealed to the curb to prevent water leakage into the curb area due to wind blown rain and capillary action. Except for the curb assembly details, the information and requirements in this section apply to all curbs. See **FIGURES 9A, 9B, and 9C** and the curb installation instructions.

Bottom Duct Connections - The blower section and optional downturn plenum have duct flanges for connection to return air and supply air ducts. Duct opening sizes and curb spacing shown in **FIGURE 9D** are for currently manufactured curbs that are available from the system manufacturer.

Roof Curb Dimensions for Model RPBL

Size		400	500/600	700	800	1050	1200
Option CJ1 - Roof Curb for RPBL							
A	inches	82-1/4	108-1/4	108-1/4	108-1/4	134-1/4	134-1/4
	mm	2089	2750	2750	2750	3410	3410
B	inches	54-1/2	43-9/16	49-1/16	54-1/2	49-1/16	54-1/2
	mm	1384	1106	1246	1384	1246	1384
C*	inches	78-1/2	104-1/2	104-1/2	104-1/2	130-1/2	130-1/2
	mm	1994	2654	2654	2654	3315	3315
D*	inches	50-13/16	39-13/16	45-5/16	50-13/16	45-5/16	50-13/16
	mm	1291	1011	1151	1291	1151	1291
Wt	lbs	150	167	173	179	202	208
	kg	68	76	78	81	92	94
Option CJ2 - Roof Curb for RPBL with Factory-Installed Downturn Plenum, Option AQ5 or AQ8							
A	inches	106-1/4	132-1/4	132-1/4	132-1/4	158-1/4	158-1/4
	mm	2699	3359	3359	3359	4020	4020
B	inches	54-1/2	43-9/16	49-1/16	54-1/2	49-1/16	54-1/2
	mm	1384	1106	1246	1384	1246	1384
C*	inches	102-1/2	128-1/2	128-1/2	128-1/2	154-1/2	154-1/2
	mm	2604	3264	3264	3264	3924	3924
D*	inches	50-13/16	39-13/16	45-5/16	50-13/16	45-5/16	50-13/16
	mm	1291	1011	1151	1291	1151	1291
Wt	lbs	177	193	199	205	228	234
	kg	80	88	91	93	103	106

Size		400	500/600	700	800	1050	1200
Option CJ4 - Roof Curb for RPBL with Field-Installed** Cooling Coil Cabinet, Option AU2 or AU3							
A	inches	150-1/4	165-1/4	170-3/4	176-1/4	1 - 3/4	202-1/4
	mm	3816	4197	4337	4477	4997	5137
B	inches	54-1/2	43-9/16	49-1/16	54-1/2	49-1/16	54-1/2
	mm	1384	1106	1246	1384	1246	1384
C*	inches	146-1/2	161-1/2	167	172-1/2	193	198-1/2
	mm	3721	4102	4242	4382	4902	5042
D*	inches	50-13/16	39-13/16	45-5/16	50-13/16	45-5/16	50-13/16
	mm	1291	1011	1151	1291	1151	1291
Wt	lbs	227	231	243	255	271	282
	kg	103	105	110	116	123	128
Option CJ5 - Roof Curb for RPBL with Field-Installed** Cooling Coil Cabinet w/Downturn, Option AU11, AU12, AU13 or AU14							
A	inches	174-1/4	189-1/4	194-3/4	200-1/4	220-3/4	226-1/4
	mm	4426	4807	4947	5086	5607	5747
B	inches	54-1/2	43-9/16	49-1/16	54-1/2	49-1/16	54-1/2
	mm	1384	1106	1246	1384	1246	1384
C*	inches	170-1/2	185-1/2	191	196-1/2	217	222-1/2
	mm	4331	4712	4851	4991	5512	5652
D*	inches	50-13/16	39-13/16	45-5/16	50-13/16	45-5/16	50-13/16
	mm	1291	1011	1151	1291	1151	1291
Wt	lbs	253	257	269	280	296	308
	kg	115	117	122	127	134	140

*C and D are roof opening dimensions.

** Field installed means that the cooling coil cabinet with or without the downturn is factory assembled and shipped separately. The roof curb is sized to accommodate the complete length of the system. The shipped-separate cooling coil cabinet with or without a downturn must be lifted to the roof separately from the packaged system, set on the roof curb, and attached to the furnace section (see instructions in Paragraph 6.3.6).

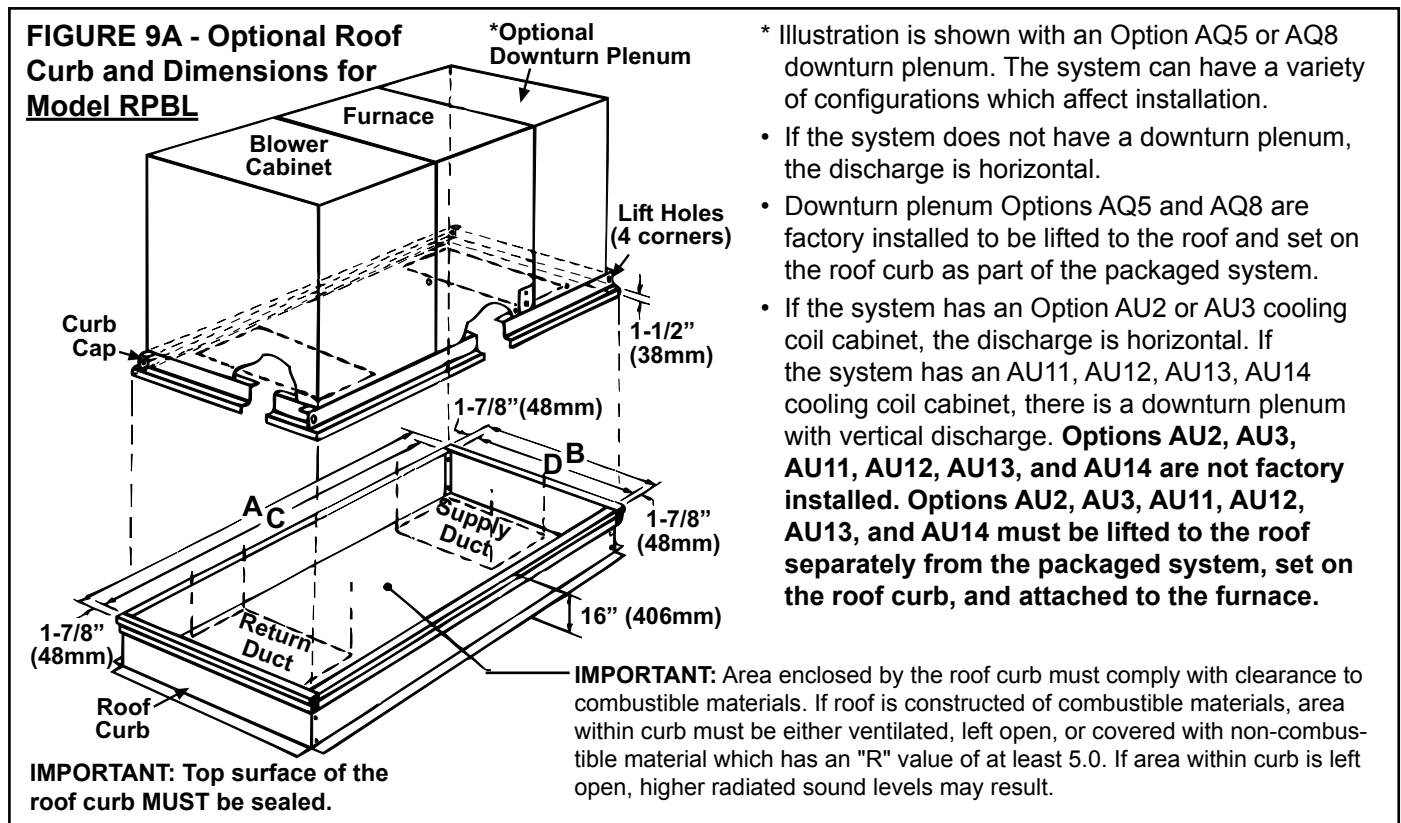

5.0 Suspension and Mounting (cont'd)

5.4 Mounting Outdoor Model (cont'd)

5.4.4 Mounting on a Roof Curb - Model RPBL (cont'd)

Roof Curb Assembly and Installation Instructions

Curbs are shipped unassembled. Field assembly and mounting on the roof are the responsibility of the installer. All required hardware necessary to complete the assembly is supplied. Before installing roof curb, verify that the size is correct for the system being installed.

1. Position curb cross rails and curb side rails as illustrated in **FIGURE 9A**. If there are two side pieces to a side, fasten them with splice plates and hardware as illustrated in the splicing detail drawing (**FIGURE 9B**). Join the corners as illustrated in the corner detail (**FIGURE 9B**).
2. Check the assembly for squareness. Adjust the roof curb so that the diagonal measurements are equal within a tolerance of + or - 1/8".

FIGURE 9B - Roof Curb Assembly

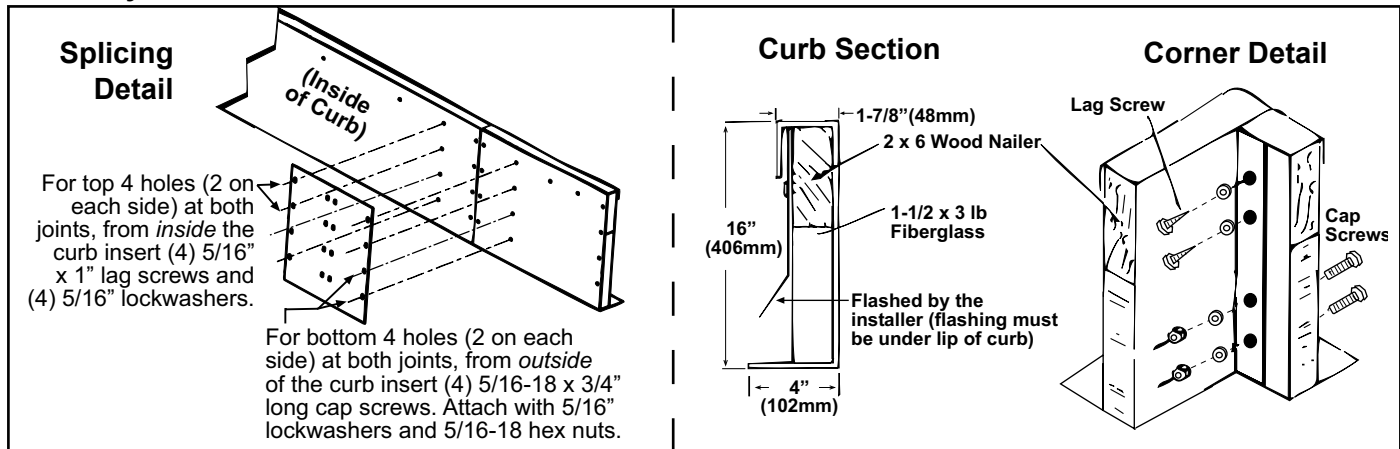

3. Level the roof curb. To ensure a good weathertight seal between the curb cap and the roof curb, the roof curb must be leveled in both directions with no twist end to end. Shim level as required and secure curb to roof deck before proceeding with flashing.
4. Install field-supplied flashing.
5. Before placing the unit into position, apply furnished 1/4" x 1-1/4" foam sealant tape to top surface of curb, making good butt joint at corners. The unit must be sealed to the curb to prevent water leakage into the curb area due to blown rain and capillary action.

FIGURE 9C - Detail of Installed Curb

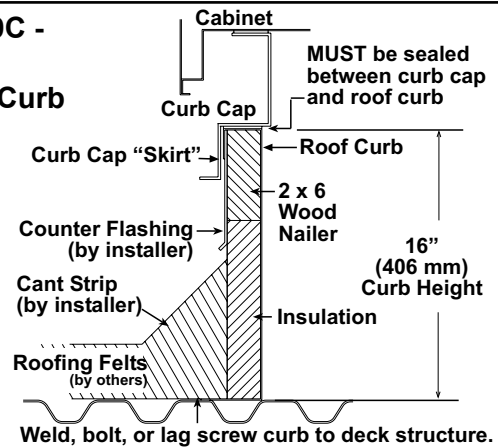
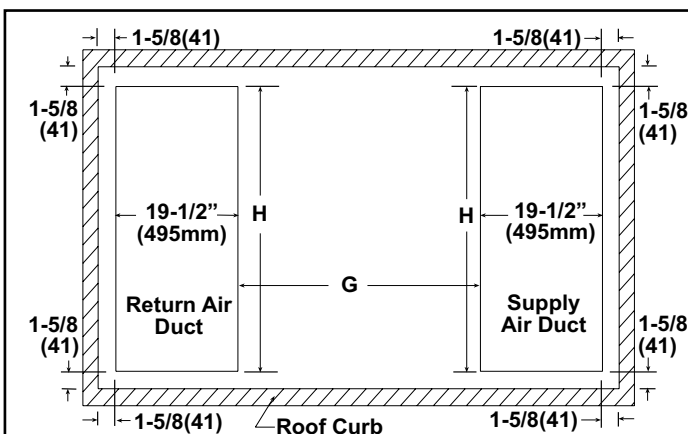

FIGURE 9D - Duct Opening Dimensions (inches and mm) in relation to Roof Curb CJ Option



RPBL Size	H		G			
			With Downturn AQ5 or AQ8 (no cooling coil)		With Cooling Coil Cabinet with Downturn, Options AU 11, 12, 13, 14	
	inches	mm	inches	mm	inches	mm
400	47-5/8	1210	60-5/16	1532	127-17/32	3239
500, 600	36-5/8	930	86-5/16	2192	142-17/32	3620
700	42-1/8	1070	86-5/16	2192	148-1/32	3760
800	47-5/8	1210	86-5/16	2192	153-17/32	3900
1050	42-1/8	1070	112-5/16	2853	174-1/32	4420
1200	47-5/8	1210	112-5/16	2853	179-17/32	4560

- 1-5/8" (41mm) is the measurement from the duct openings to the inside edge of the roof curb.
- Openings for ductwork should be 1" (25mm) larger than the duct size for installation clearance.

6.0 Mechanical

6.1 Gas Piping and Pressures

WARNING

This appliance is equipped for a maximum gas supply pressure of 1/2 psi, 3.5 kPa, or 14 inches water column. NOTE: Supply pressures higher than 1/2 psi require installation of an additional service regulator external to the unit.

Pressure Testing Supply Piping

Test Pressure Above 1/2 PSI: Disconnect the heater and manual valve from the gas supply which is to be pressure tested. Cap or plug the supply line.

Test Pressure Below 1/2 PSI: Before testing, close the manual valve on the heater.

WARNING

Manifold gas pressure must never exceed 3.5" w.c. for natural gas or 10" w.c. for propane gas.

All piping must be in accordance with requirements outlined in the National Fuel Gas Code ANSI/Z223.1 (latest edition) or CSA B149.1 and B149.2. (See Paragraph 1.4.) Gas supply piping installation should conform with good practice and with local codes. These separated-combustion units for natural gas are orificed for gas having a heating value of 1000 (±50) BTU per cubic ft. If the gas at the installation does not meet this specification, consult the factory for proper orificing.

Pipe joint compounds (pipe dope) shall be resistant to the action of liquefied petroleum gas or any other chemical constituents of the gas being supplied.

Install a ground joint union and manual shutoff valve upstream of the unit control system. The 1/8" plugged tapping in the shutoff valve provides connection for supply line pressure test gauge. The National Fuel Gas Code requires the installation of a trap with a minimum 3" drip leg. Local codes may require a longer drip leg, typically 6".

After all connections are made, disconnect the pilot supply at the control valve and bleed the system of all air. Reconnect the pilot line and leak test all connections by brushing on a soap or leak-detecting solution.

WARNING

All components of a gas supply system must be leak tested prior to placing the equipment in service. NEVER TEST FOR LEAKS WITH AN OPEN FLAME. See Hazard Levels, page 2.

Gas Connection

FIGURE 10 - Gas Connection and Gas Train Manifold Arrangements

Gas Connection Size (Not Gas Supply Line Size)		
SSCBL / RPBL	400	500, 600, 700, 800, 1050, 1200
Natural Gas	1"	1-1/4"
Propane	1"	1-1/4"

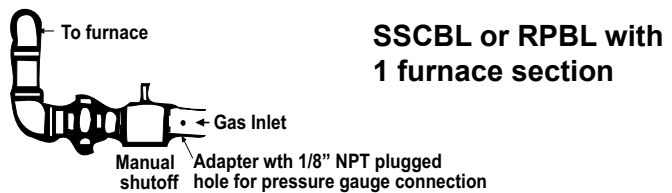
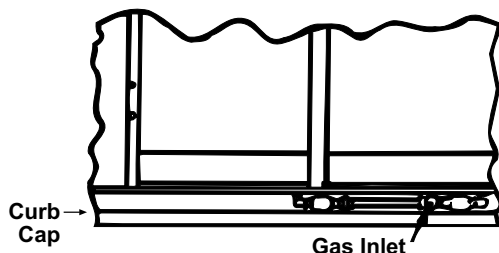

SSCBL or RPBL with 2 furnace sections

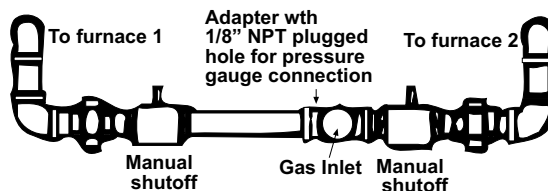

SSCBL or RPBL with 3 furnace sections

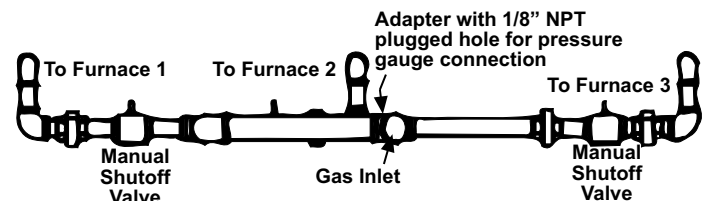

6.0 Mechanical (cont'd)

6.1 Gas Piping and Pressures (cont'd)

Sizing Gas Supply Lines

Capacity of Piping - Cubic Feet per Hour based on 0.3" w.c. Pressure Drop Specific Gravity for Natural Gas -- 0.6 (Natural Gas -- 1000 BTU/Cubic Ft) Specific Gravity for Propane Gas -- 1.6 (Propane Gas -- 2550 BTU/Cubic Ft)										
Length of Pipe	Diameter of Pipe									
	1"		1-1/4"		1-1/2"		2"		2-1/2"	
	Natural	Propane	Natural	Propane	Natural	Propane	Natural	Propane	Natural	Propane
20'	350	214	730	445	1100	671	2100	1281	3300	2013
30'	285	174	590	360	890	543	1650	1007	2700	1647
40'	245	149	500	305	760	464	1450	885	2300	1403
50'	215	131	440	268	670	409	1270	775	2000	1220
60'	195	119	400	244	610	372	1105	674	1850	1129
70'	180	110	370	226	560	342	1050	641	1700	1037
80'	170	104	350	214	530	323	990	604	1600	976
90'	160	98	320	195	490	299	930	567	1500	915
100'	150	92	305	186	460	281	870	531	1400	854
125'	130	79	275	168	410	250	780	476	1250	763
150'	120	73	250	153	380	232	710	433	1130	689
175'	110	67	225	137	350	214	650	397	1050	641
200'	100	61	210	128	320	195	610	372	980	598

Note: When sizing supply lines, consider possibilities of future expansion and increased requirements.
Refer to National Fuel Gas Code for additional information on line sizing.

Manifold or Orifice (Valve Outlet) Pressure Settings

Measuring manifold gas pressure cannot be done until the heater is in operation. It is included in the steps of the "Check-Test-Start" procedure in Paragraph 9.0. The following warnings and instructions apply.

For Natural Gas: When the heater leaves the factory, the combination valve is set so that the outlet gas pressure of a single-stage valve or high fire of a two-stage valve is regulated to 3.5" w.c. Low fire on a two-stage valve is set to 1.8" w.c. Inlet supply pressure to the valve must be a minimum of 5" w.c. or **as noted on the rating plate** and a maximum of 14" w.c. **NOTE: Always check the rating plate for minimum gas supply pressure.** Minimum supply pressure requirements vary based on size of burner and the gas control option. Most units require a minimum of 5" w.c. of natural gas as stated above, but larger sizes with electronic modulation require a minimum of 6" w.c. natural gas supply pressure.

For Propane: When the heater leaves the factory, the combination valve is set so that the outlet gas pressure of a single-stage valve or high fire of a two-stage valve is 10" w.c. Low fire on a two-stage valve is set to 5" w.c. Inlet pressure to the valve must be a minimum of 11" w.c. and a maximum of 14" w.c.

Before attempting to measure or adjust manifold gas pressure, the inlet (supply) pressure must be within the specified range for the gas being used both when the heater is in operation and on standby. Incorrect inlet pressure could cause excessive manifold gas pressure immediately or at some future time.

Instructions to Check Valve Outlet (Manifold) Pressure:

1) With the manual valve (on the combination valve) positioned to prevent flow to the main burners, connect a manometer to the 1/8" pipe outlet pressure tap in the valve. NOTE: A manometer (fluid-filled gauge) is recommended rather than a spring type gauge due to the difficulty of maintaining calibration of a spring type gauge.

2) Open the valve and operate the heater. Measure the gas pressure to the manifold. To measure the low stage pressure on units equipped with a two-stage valve, disconnect the wire from the "HI" terminal on the valve. (Be sure to reconnect the wire.)

Normally adjustments should not be necessary to the factory preset regulator. If adjustment is necessary, set pressure to correct settings by turning the regulator screw IN (clockwise) to increase pressure. Turn regulator screw OUT (counterclockwise) to decrease pressure. Consult the valve manufacturer's literature provided with the furnace for more detailed information.

CAUTION: DO NOT bottom out the gas valve regulator adjusting screw. This can result in unregulated manifold pressure causing overfire and heat exchanger failure.

6.2 Venting and Combustion Air

6.2.1 Separated-Combustion Model SSCBL

Each furnace section in the packaged system **MUST BE** equipped with both combustion air and exhaust piping to the outdoors. Refer to **FIGURES 2 and 3** in Paragraph 4.1 for locations of vent and inlet air collars. The vent pipe collar is 6" O.D.; the inlet air collar is 6" I.D. Either a horizontal (Option CC6) or vertical (Option CC2) combustion air inlet/vent terminal concentric adapter assembly must be ordered for field installation to each furnace section. Each concentric adapter assembly is shipped in a separate carton. Be sure that the concentric adapter carton(s) are at the installation site.

These instructions apply to installation and use of the concentric adapter and vent/combustion air kits (Option CC2 or CC6) designed for use with all Model SSCBL systems. The vent/combustion systems illustrated in this manual are the only vent/combustion air systems approved for use with a Model SSCBL packaged heating system.

WARNING

Do not use an existing venting system. Installation of a combustion air/vent system ordered as Option CC2 or Option CC6 is required for each furnace section.

Installation should be done by a qualified agency in accordance with these instructions. The qualified service agency installing this separated-combustion system is responsible for the installation.

WARNING

Model SSCBL separated combustion units are not designed or approved for use in atmospheres containing flammable vapors or atmospheres highly laden with chlorinated vapors. See Hazard Levels, page 2.

6.2.1.1 Specific Venting Requirements - Model SSCBL

(read all venting information before installing)

1) Vent/Combustion Air Kit (ordered with the heater as either Option CC2 or Option CC6)

All Model SSCBL installations **require** a vent/combustion air kit for **each** furnace section.

Follow the instructions on pages 19-21 to install a horizontal vent/combustion air system (Option CC6). Follow the instructions on pages 22-25 to install a vertical vent/combustion air system (Option CC2).

2) Type of Pipe (field-supplied)

Vent Pipe Between the Furnace Section and the Concentric Adapter Box - Use either vent pipe approved for a Category III appliance OR single-wall, 26-gauge or heavier galvanized (or a material of equivalent corrosion resistance) vent pipe.

Vent Pipe Between the Concentric Adapter Box and the Vent Cap - Double-wall (Type B) vent pipe is required. The length of vent pipe that extends through the box and runs concentric through the combustion air pipe must be one-piece with no joints.

Combustion Air Inlet Pipe - Sealed, single-wall galvanized pipe is recommended.

3) Venter Outlet and Combustion Air Inlet Collars

Each furnace section has both an inlet air and a venter outlet connection (See **FIGURE 2**). Both are 6" diameter for all sizes.

- **NOTE:** If using 7" pipe (see table below), use a taper-type 6" to 7" enlarger to attach the vent pipe and a 7" to 6" reducer to attach the combustion air pipe.

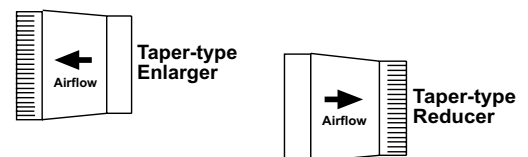

4) Pipe Diameter and Length

Pipe diameters and maximum indoor vent lengths apply to both horizontal and vertical vents. Add all straight sections and equivalent lengths for elbows. The total length of the straight sections and elbows must not exceed the Maximum Length.

6.0 Mechanical (cont'd)

6.2 Venting and Combustion Air (cont'd)

6.2.1 Separated-Combustion Model SSCBL (cont'd)

6.2.1.1 Specific Venting Requirements (cont'd) (*read all before installing*)

4) Pipe Diameter and Length (cont'd)

Maximum Pipe Length from EACH Furnace Section to a Unique Concentric Adapter Box -- Minimum length is five feet (1.5M).					
Model SSCBL	Pipe Diameter		Maximum Length	Equivalent Length for an Elbow	
	Vent	Inlet Air		90°	45°
500, 600	6"	6"	50 ft (15 M)	8 ft (2.4M)	4 ft (1.2M)
400, 700, 800, 1050, 1200	6"	6"	30 ft (9 M)	8 ft (2.4M)	4 ft (1.2M)
All Sizes	7"	7"	70 ft (21M)	8 ft (2.4M)	4 ft (1.2M)

The outside (terminal) portion of the inlet air pipe is 8" in diameter. The 5" I.D. diameter double-wall vent pipe runs through the 8" inlet air pipe. See **FIGURE 13**, page 17. The outdoor lengths depend on the installation. Outdoor vent length requirements are listed in the installation instructions for the horizontal and vertical vent/combustion air kits.

5) Joints/Seals

Provide pipe as specified in Requirement No. 2 and make joints as follows:

- **If using Category III vent pipe runs**, follow the pipe manufacturer's instructions for joining and sealing Category III vent pipe sections.
- **If using single-wall vent pipe runs**, secure slip-fit pipe connections using sheetmetal screws or rivets. Seal all joints with aluminum tape or silicone sealant.
- **To seal joints in the single-wall combustion air pipe**, secure slip fit pipe connections using sheetmetal screws or rivets. Seal all joints with aluminum tape or silicone sealant.
- **To seal joint in the terminal section of double-wall vent pipe (allowed ONLY ABOVE the concentric pipes on a VERTICAL vent)**, follow the pipe manufacturer's instructions for joining and sealing double-wall vent pipe sections.
- **When joining the terminal section of double-wall vent pipe to the vent cap**, follow the illustrated step-by-step instructions in **FIGURE 11**.

When joining the terminal section of double-wall vent pipe to a single-wall or Category III vent pipe run, follow the illustrated step-by-step instructions in **FIGURE 12**.

FIGURE 11 - Follow STEPS to join Double-Wall (Type B) Pipe and the Vent Terminal Cap (horizontal or vertical)

(NOTE: Pipes and vent caps may not look exactly as shown in the illustrations. Instructions apply to both horizontal and vertical vent kits.)

Figure 11 - STEP 1

Place a continual 3/8" bead of silicone sealant around the circumference of the vent cap collar. This will prevent any water inside the vent cap from running down the double-wall pipe.

Do STEP 2 immediately following STEP 1.



Figure 11 - STEP 2

Insert the collar on the vent cap inside the inner wall of the double-wall pipe. Insert as far as possible. Add additional silicone sealant to fully close any gaps between the vent cap and the double wall pipe. This is necessary to prevent water from entering the double wall pipe.

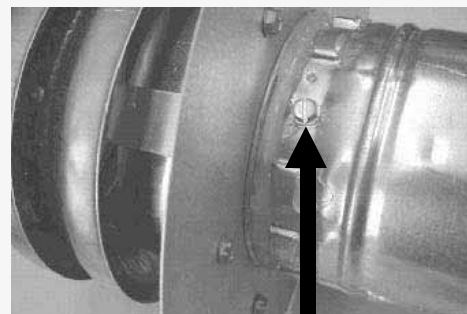
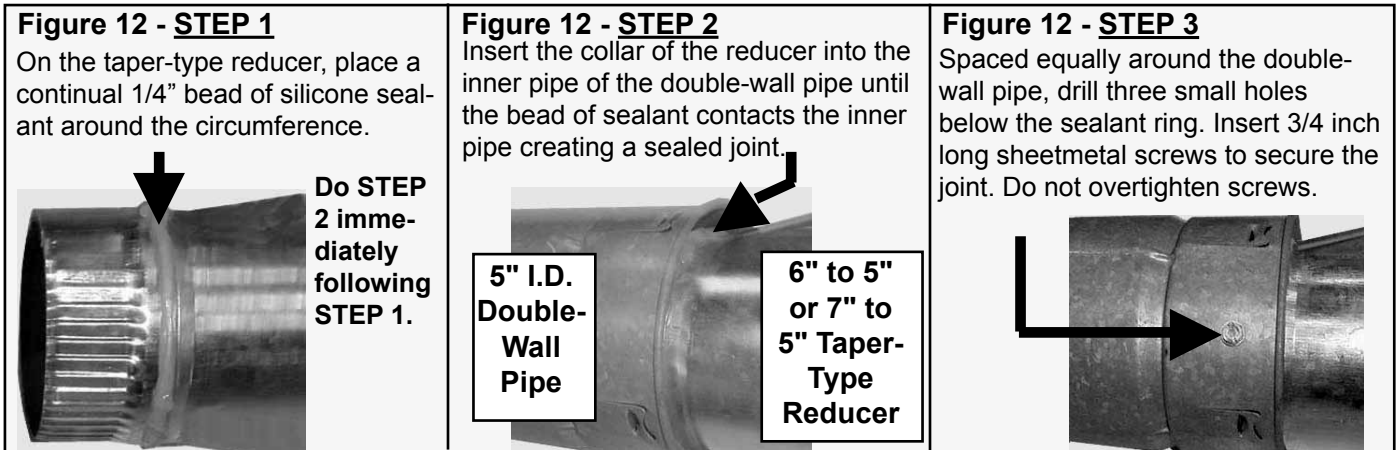

Figure 11 - STEP 3

Secure the vent cap to the double-wall pipe by drilling and inserting a 3/4" long sheetmetal screw into the vent cap collar. Do not overtighten screw.

FIGURE 12 - Follow STEPS to join the Double-Wall (Type B) Pipe to the Taper-type Reducer that Joins it to the Single-Wall or Category III Vent Run

Make this connection a maximum of 6" (152mm) from the concentric adapter box.



6) Support

Support horizontal runs every six feet (1.8M). Support vertical runs of type "B" double-wall or Category III vent pipe in accordance with the requirements of the pipe manufacturer. Support single-wall vertical pipe in accordance with accepted industry practices. Do not rely on the heater or the adapter box for support of either horizontal or vertical pipes. Use non-combustible supports on vent pipe.

7) Clearance

Do not enclose the vent pipe or place pipe closer than 6" (152mm) to combustible material.

8) Concentric Adapter Box

All separated combustion installations **require** a concentric adapter box as illustrated in **FIGURE 13**. The concentric adapter box is included in the vent/combustion air kit. Installation instructions depend on whether the vent system is horizontal (Option CC6) or vertical (Option CC2).

FIGURE 13 - A Concentric Adapter Box is Required for EACH Furnace Section of a Model SSCBL Installation

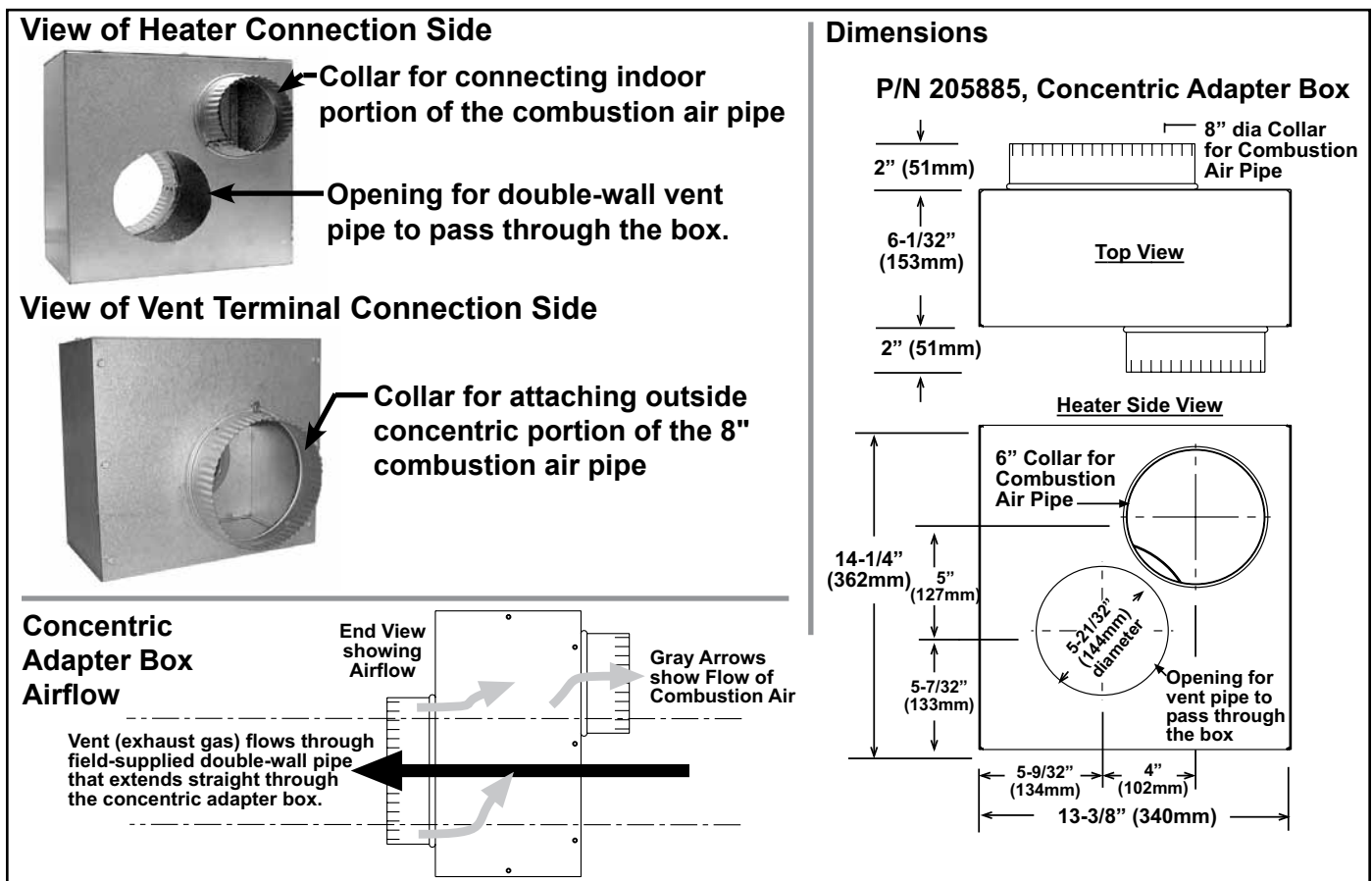

6.0 Mechanical (cont'd)

6.2 Venting and Combustion Air (cont'd)

6.2.1 Separated-Combustion Model SSCBL (cont'd)

FIGURE 14 - Concentric Adapter Box Connections (6" or 7" pipe)

- If using 6" diameter pipes, a 6" to 5" (152 to 127 mm) reducer is required in the vent pipe.

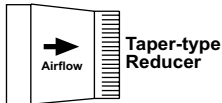

- If using 7" diameter pipes, a 7" to 5" (178 to 127 mm) reducer is required in the vent pipe and a 6" to 7" (152 to 178 mm) enlarger is required for attaching the combustion air pipe.

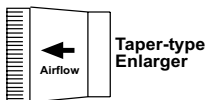
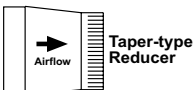

6.2.1.1 Specific Venting Requirements (cont'd) (read all before installing)

Pipe Connections at the Concentric Adapter Box

When pipe diameters differ, depending on direction of airflow, join the pipes with either a taper-type reducer or enlarger. Refer to illustrations in **FIGURE 14** for pipe connection requirements at the concentric adapter box.

Do **NOT** make actual connections until after reading the instructions and length requirements for installing the vent/combustion air kit. **The connection requirements are the same for both vertical and horizontal systems, but the length of the double-wall pipe will vary.**

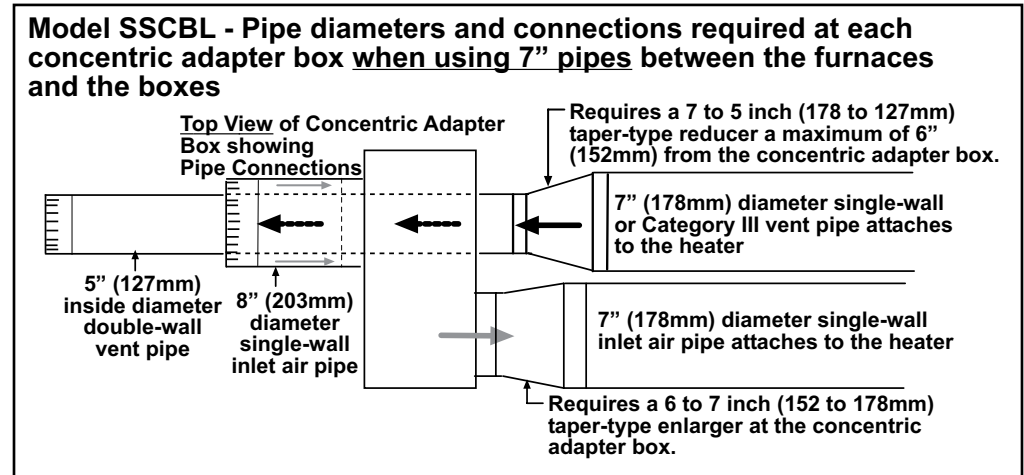
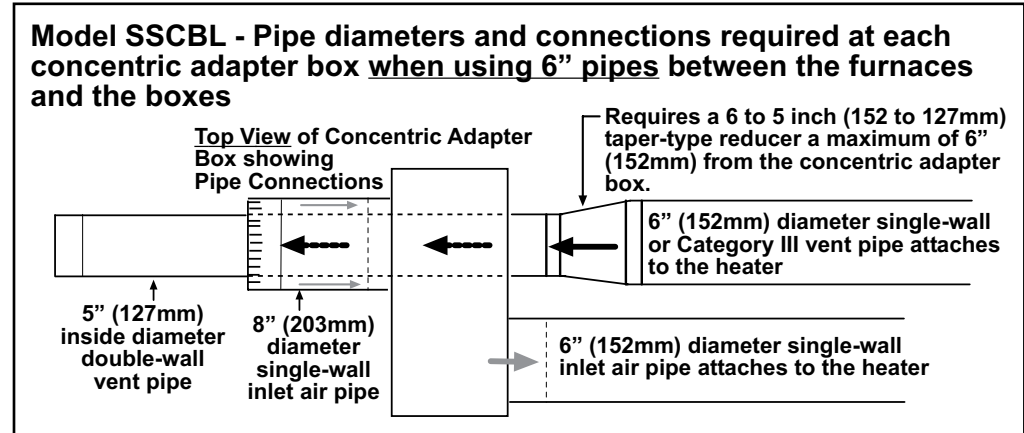

Is the Vent Terminal HORIZONTAL OR VERTICAL?

Follow the instructions for the Vent Terminal being installed:

Horizontal, Option CC6, instructions begin on page 19.

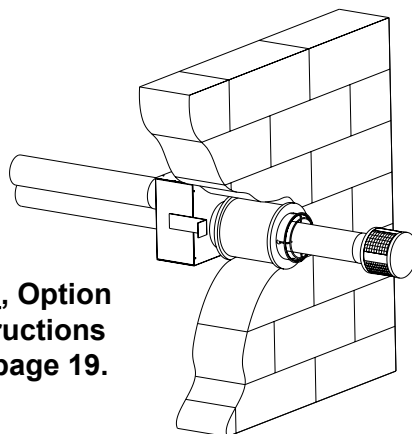

Vertical, Option CC2, instructions begin on page 22.

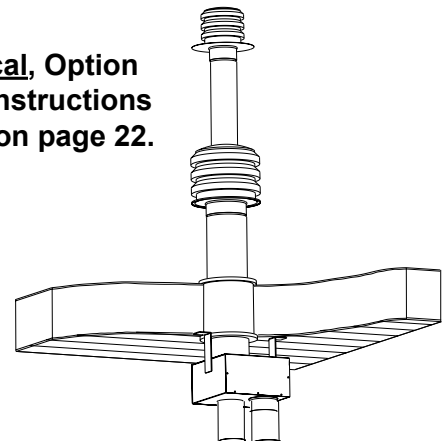

6.2.1.2 Horizontal Vent Instructions - Model SSCBL

FIGURE 15 - Parts in each Horizontal Vent Terminal/Combustion Air Package (Option CC6) - One required for each furnace section.

Field-supplied installation requirements:



Installation Instructions for Horizontal Vent Kit Option CC6 - Model SSCBL

Clearances to a Horizontal Vent Terminal

WARNING
All vent terminals must be positioned or located away from fresh air intakes, doors and windows to preclude combustion products from entering occupied space. Failure to comply could result in severe personal injury or death and/or property damage.

Components Required - Factory and Field

Qty	P/N	Description
1	205883	Complete Horizontal Vent Kit (Same as Option CC6)
1	205885	Concentric Adapter Box Assembly (See FIGURE 13 , page 17.)
1	53316	Screened Exhaust Assembly (illustrated below)
1	205894	Inlet Guard (illustrated below)
4	37661	#10-16 x 1/2" long Screws to attach the inlet guard
2	207232	Brackets for attaching Concentric Adapter Box (FIGURE 16B , page 20)
1	53335	Tube of High Temperature (450°F) Silicone Sealant

<p>Screened Exhaust Assembly, P/N 53316</p> 	<p>Inlet Guard, P/N 205894</p> 
--	---

- Vent pipes - see requirements, page 15.
- Combustion air pipes - see requirements, page 15.
- Taper-type vent pipe diameter reducers and/or increasers as required.
- Thimble (a thimble is not required if wall is of non-combustible construction).
- Flashing.
- Sheetmetal screws, tape, and sealant as required.

1. Determine the location on the outside wall for the vent terminal. Location must comply with vent length requirements, Requirement No. 4 on pages 15-16. In most applications, the terminal would be on a level with the heater mounting height. Allow 1/4" per foot (6mm per 305mm) downward pitch for condensate drain.

The distance of the termination of the horizontal vent from adjacent public walkways, adjacent buildings, openable windows, and building openings must be in accordance with local codes or, in the absence of local codes, must conform with National Fuel Gas Code Z223.2. Local codes supersede all provisions in these instructions and in the National Fuel Gas Code. Minimum clearances for the horizontal vent terminal are shown below. Also, select a location that complies with adjoining building clearances as shown in **FIGURE 17**, page 21.

Products of combustion can cause discoloring of some building finishes and deterioration of masonry materials. Applying a clear silicone sealant that is normally used to protect concrete driveways can protect masonry materials. If discoloration is an esthetic problem re-locate the vent or install a vertical vent.

Structure	Minimum Clearances for Vent Terminal Location (all directions unless specified)
Forced air inlet within 10 ft (3.1M)*	3 ft (0.9M) above
Combustion air inlet of another appliance	6 ft (1.8M)
Door, window, or gravity air inlet (any building opening)	4 ft (1.2M) horizontally
	4 ft (1.2M) below
	1 ft (305mm) above
Electric meter, gas meter ** and relief equipment	U.S. - 4 ft (1.2M) horizontally; Canada - 6 ft (1.8M)
Gas regulator **	U.S. - 3 ft (0.9M); Canada - 6 ft (1.8M) horizontally
Adjoining building or parapet	6 ft (1.8M)
Adjacent public walkways	7 ft (2.1M) above
Grade (ground level)	3 ft (.9M) above***
*Does not apply to the inlet of a direct vent appliance. **Do not terminate the vent directly above a gas meter or service regulator. *** Consider local snow depth conditions. The vent must be at least 6" (152mm) higher than anticipated snow depth.	

2. Install the Vent Pipe and Combustion Air Pipe Runs - Use the type of pipe specified in Requirement No. 2, page 15. Comply with requirements in Requirement No. 3, page 15, when attaching pipes to the heater.

Seal all joints. Due to the high temperature, **do not** enclose the exhaust pipe or place pipe closer than 6" (152 mm) to combustible material. Extend the runs close to the wall location selected in Step 1. Support pipes as required in Requirement No. 6, page 17.

6.0 Mechanical (cont'd)

6.2 Venting and Combustion Air (cont'd)

FIGURE 16A - Prepare holes so that there is a minimum of 26-1/8" (664mm) between centerlines of each terminal pipe.

6.2.1.2 Horizontal Vent Instructions - Model SSCBL (cont'd)

3. Prepare a hole through the outside wall for the 8" (203mm) diameter combustion air pipe. Outside wall construction thickness should be between 1" (25mm) minimum and 48" (1143mm) maximum. The larger diameter combustion air pipe serves as clearance for the vent pipe on non-combustible construction. A thimble may be required depending on wall construction and/or local codes.

When installing a system with more than one furnace section, a minimum of 26-1/8" (664mm) is required between the centerlines of each terminal pipe (**FIGURE 16A**).

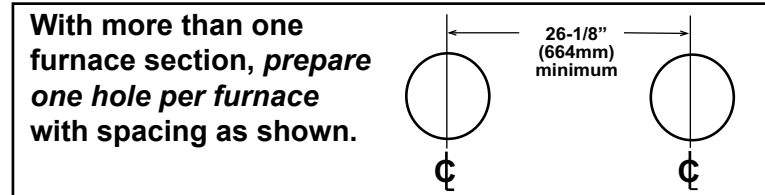
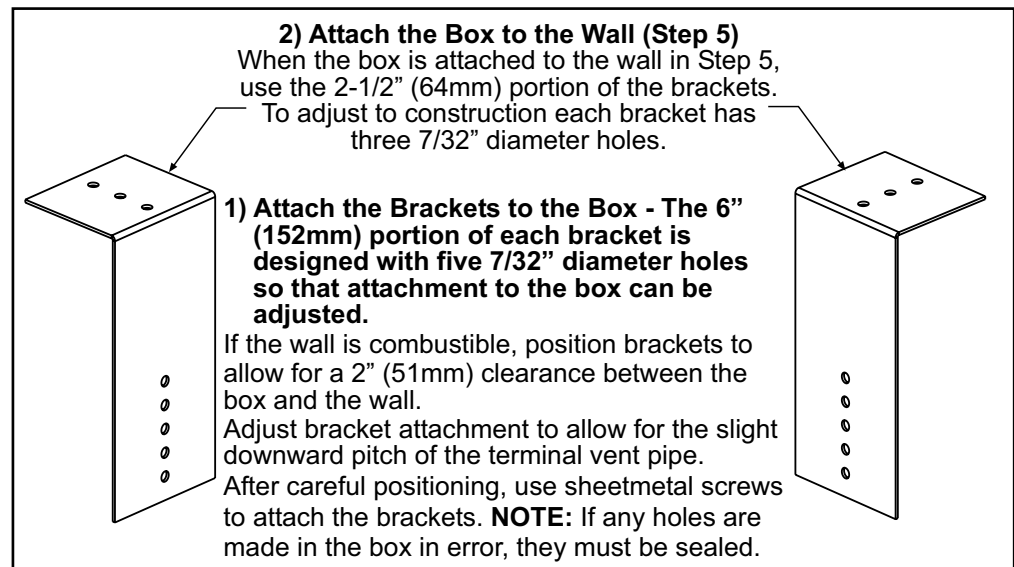

FIGURE 16B - Brackets for Attaching the Concentric Adapter Box to the Wall

4. Prepare the Concentric Adapter Box

a) Attach the brackets to the box. Follow the instructions in **FIGURE 16B**.



b) Attach the outside portion of the combustion air pipe to the box. Determine the length by measuring the bracket length from box to wall, plus the wall thickness, plus 2" (51 mm). (The inlet air pipe should extend beyond the outside wall approximately 2" (51mm).)

Attach the inlet air pipe to the collar of the concentric adapter with sheetmetal screws and seal.

5. Attach the concentric adapter box to the wall. Insert the combustion air pipe through the wall. Attach the brackets (**FIGURE 16B**) to the wall. On the outside, caulk or flash the inlet air pipe. Flashing is field-supplied.

6. Position the inlet guard over the end of the combustion air pipe. See **FIGURE 17**. Attach the guard to the inlet air pipe with the four 1/2" long screws.

7. Determine length and install the double-wall terminal vent pipe.

a) Determine length of pipe. The length of the vent pipe is determined by the installation within the maximum and minimum requirements. See **FIGURE 17**, to determine lengths of each segment and calculate the total length required. The vent pipe extending through the box and the inlet air pipe **must be one piece of double-wall vent pipe without joints**. The transition to the single-wall or Category III vent pipe run, must be a maximum of 6" (152mm) from the heater side of the box.

b) Install double-wall terminal vent pipe. Being sure the vent pipe is in the proper flow direction, slide the end through the box. Position the vent pipe so that it will extend between 16" (406mm) and 24" (610mm) past the end of the combustion air pipe and no more than 6" (152mm) out of the box toward the heater.

FIGURE 17 - Installation of a Typical Separated-Combustion Unit with Horizontal Vent and Combustion Air Pipes (Option CC6)

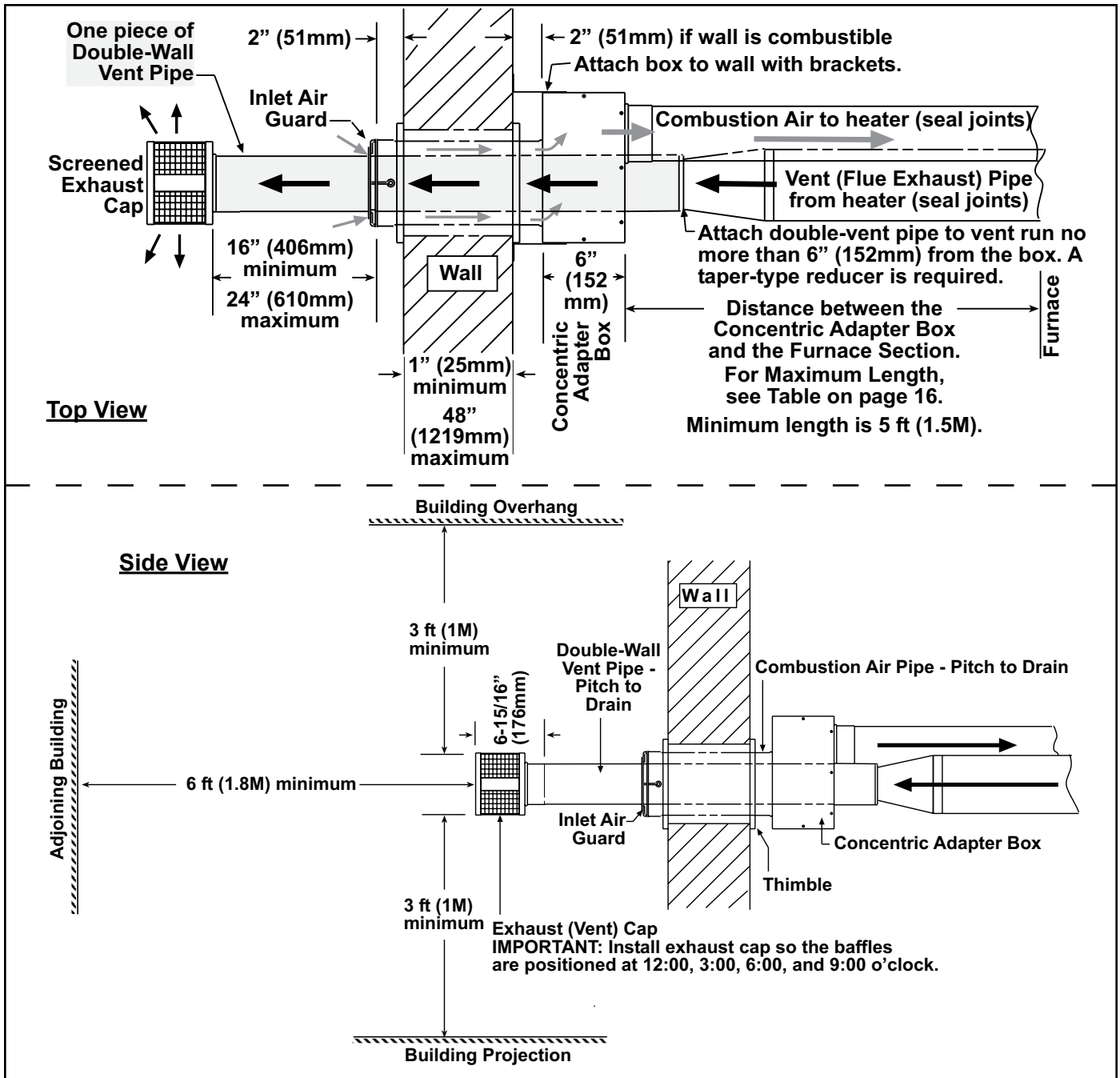

Use a taper-type reducer to attach the 5" double-wall vent pipe to the 6" or 7" single-wall or Category III vent pipe run. Follow the instructions in **FIGURE 12**, page 17.

8. Attach the exhaust (vent) cap to the end of the vent pipe. Align the cap so that its baffle strips are positioned on the horizontal and vertical centerlines (See **FIGURE 17**). Follow the instructions in **FIGURE 11**, page 16, to attach the exhaust cap. (**NOTE:** If vent pipe is inserted from outside, cap may be attached before the double-wall vent pipe is installed. If cap is attached first, be sure the baffle strips are positioned correctly when attaching the vent terminal pipe to the vent run.)

9. Seal the vent pipe. Verify that the double-wall section of vent pipe has a slight downward drop (1/4" per foot / 6mm per 305mm) toward the vent terminal end. Use

silicone sealant and seal the circumference of the pipe and the opening of the box. Seal the area around the pipe completely.

10. Attach the indoor combustion air pipe. If using 6" pipes, attach the single-wall combustion air pipe run to the collar on the concentric adapter box with sheetmetal screws. If using 7" pipe, install a taper type enlarger as illustrated in **FIGURE 14**, page 18. Seal joints with tape or sealant.

Installation of the horizontal vent and combustion air system on your separated-combustion unit is complete. **Verify compliance with all venting installation requirements, pages 15-18, and illustrated in FIGURE 17.**

6.0 Mechanical (cont'd)

6.2 Venting and Combustion Air (cont'd)

Components Required - Factory and Field



FIGURE 18 - Parts in the Vertical Vent Terminal/Combustion Air Package (Option CC2) - One required for each furnace section.

Field-supplied installation requirements:

6.2.1 Separated-Combustion Model SSCBL (cont'd)

6.2.1.3 Vertical Vent Instructions - Model SSCBL

Qty	P/N	Description
1	205896	Complete Vertical Vent Kit (Same as Option CC2)
1	205885	Concentric Adapter Box Assembly (See FIGURE 13 , page 17.)
1	53326	Exhaust (Vent) Terminal (illustrated below)
1	53330	Combustion Air (illustrated below)
2	207232	Brackets for attaching Concentric Adapter Box (FIGURE 20 , page 23)
1	53335	Tube of High Temperature Silicone Sealant

<p>Exhaust (Vent) Terminal, P/N 53326</p> 	<p>Combustion Air Inlet, P/N 53330</p> 
--	---

- Vent pipes - see requirements, page 15.
- Combustion air pipes - see requirements, page 15.
- Taper-type pipe diameter reducers and/or increasers as required
- Thimble (a thimble is not required if wall is of non-combustible construction)
- Flashing
- Sheetmetal screws, tape, and sealant as required

Installation Instructions for Vertical Vent/Combustion Air Kit Option CC2

1. Determine the Location of the Vent Terminal(s). - Select a location away from fresh air intakes, allowing space for each concentric adapter box inside. Vent terminals must be located from adjacent buildings as shown in **FIGURE 24**, page 25. A vent terminal is required for each furnace section. When more than one vertical concentric vent/combustion air terminal (Option CC2) is being installed, the minimum spacing between vent centerlines is determined by the minimum outdoor design temperature (most extreme outdoor condition at the installation site).

Minimum Outdoor Design Temperature		Minimum Spacing between Centerlines of Vent Pipes in Vertical Combustion Air/Vent Terminals (Option CC2)	
		inches	mm
°F	°C		
31 or warmer	0 or warmer	36	914
-10 to 30	-23 to -1	60	1524
less than -10	less than -23	84	2134

2. Install the Vent Pipe and Combustion Air Pipe Run(s). - Use the type of pipe specified (Requirement No. 2, page 15), and comply with the attachment requirements in Requirement No. 3, page 15. Length must comply with Requirement No. 4, pages 15-16.

Seal all joints. Due to the high temperature, **do not** enclose the exhaust pipes or place pipes closer than 6" (152 mm) to combustible material. Provide supports for the pipes. Extend the runs to close to the roof at the location(s) selected in Step 1 above.

3. Prepare hole(s) through the roof for the 8" (203mm) diameter combustion air pipe. - A thimble may or may not be required depending on building construction and/or local codes. The larger diameter combustion air pipe serves as clearance for the vent pipe on non-combustible construction.

4. Prepare the Concentric Adapter Box

a) Attach the brackets to the box. Follow the instructions in **FIGURE 20**.

b) Attach the outside portion of the combustion air pipe to the box. Determine the length of the combustion air pipe so that dimension "X" in **FIGURE 21** is equal to the bracket length, plus the roof thickness, plus anticipated snow depth, but does not exceed 48" (1219mm) or have less than 18" (457mm) of pipe above the roof. Attach the inlet air pipe to the collar of the concentric adapter box with sheetmetal screws.

WARNING

All vent terminals must be positioned or located away from fresh air intakes, doors and windows to preclude combustion products from entering occupied space. Failure to comply could result in severe personal injury or death and/or property damage.

FIGURE 20 - Brackets for Attaching the Concentric Adapter Box to the Roof

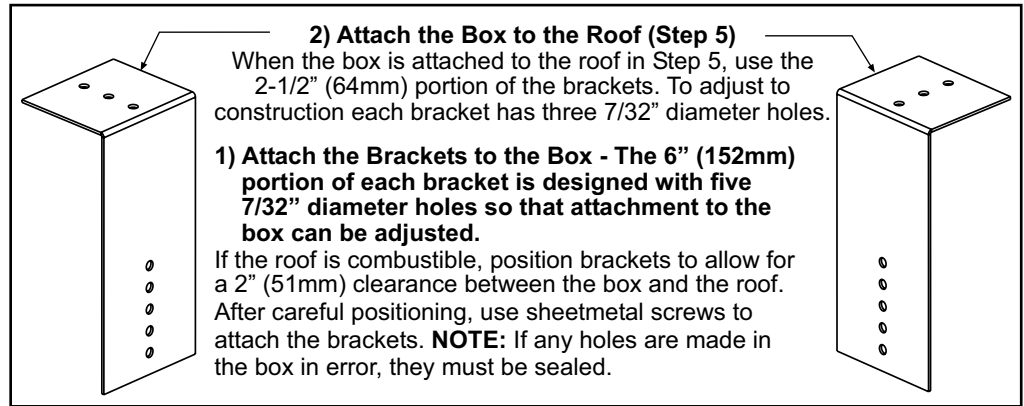

5. Attach the concentric adapter box to the roof. On the inside, insert the combustion air pipe up through the opening and attach brackets to the roof. (See FIGURES 21 and 22.) On the outside, flash the combustion air pipe to the roof. Flashing is field supplied.

6. Determine the length and install the double-wall vent pipe.

a) Determine the length. See FIGURE 21 to determine the required length of the vent pipe. The vent pipe extending through the box and the inlet air pipe **must be one piece of double-wall vent pipe without joints.**

FIGURE 21 - Assemble Concentric Adapter Box, Outdoor Combustion Air Pipe, and Double-Wall Vent Pipe

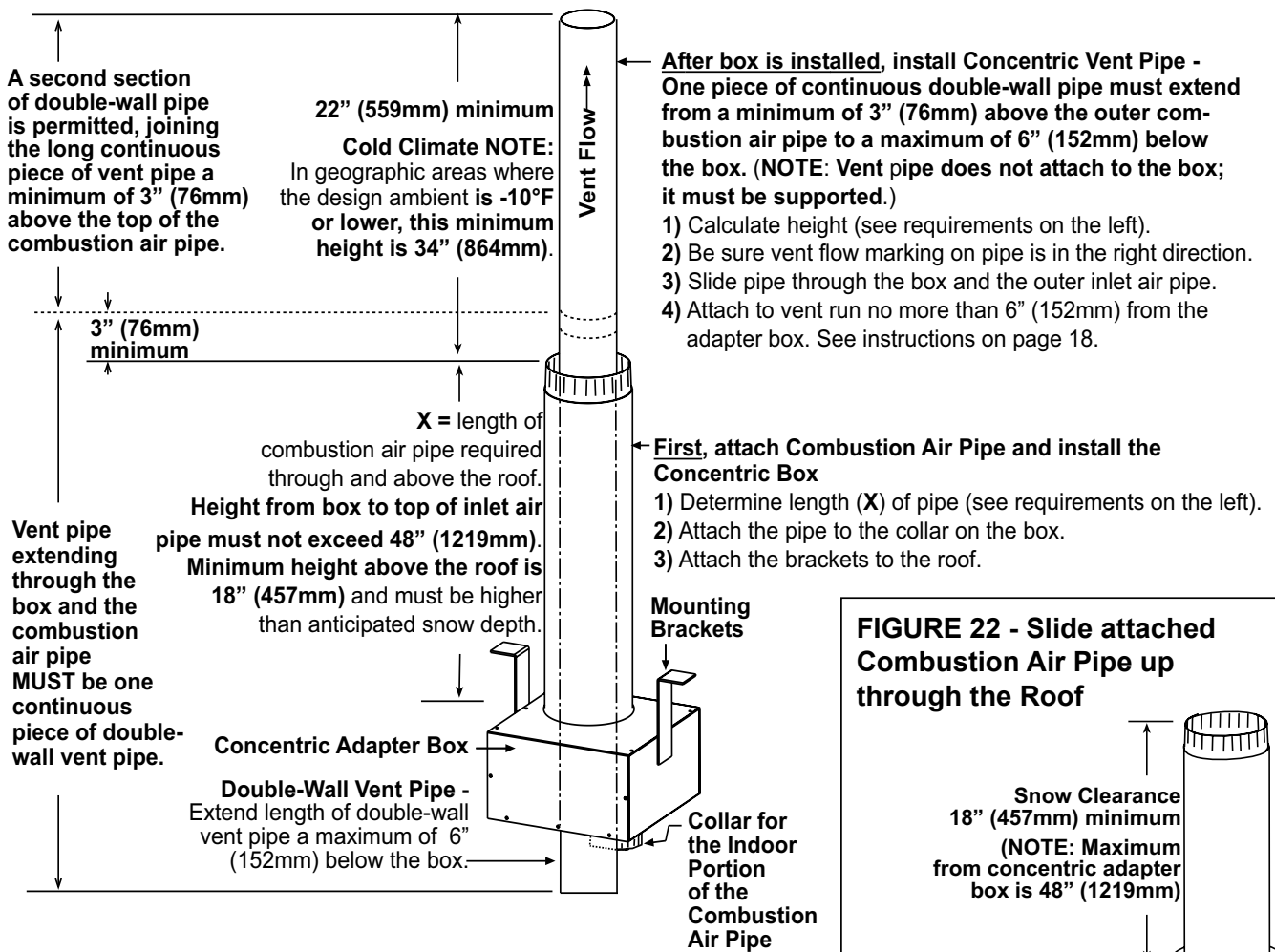
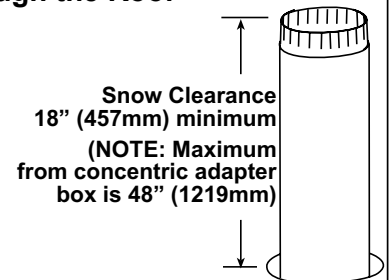

FIGURE 22 - Slide attached Combustion Air Pipe up through the Roof



Outside View with concentric adapter box attached to underside of roof. Install field-supplied flashing at roof opening.

6.0 Mechanical (cont'd)

6.2 Venting and Combustion Air (cont'd)

6.2.1 Separated- Combustion Model SSCBL (cont'd)

6.2.1.3 Vertical Vent Instructions - Model SSCBL (cont'd)

Determine the minimum length by adding the requirements. Starting at the bottom, the maximum the vent pipe can extend below the box is 6" (152mm); **plus** 6" (152mm) through the box; **plus** length of bracket extending above the box; **plus** the width of the roof; **plus** the height of the outside combustion air pipe above the roof; **plus** a minimum of 3" (76mm) beyond the top of the inlet air pipe. Total is the minimum length of the vent pipe section. If the actual piece of vent pipe is longer, extend it further above the combustion air pipe. Do not extend it more than 6" (152mm) below the box.

b) Install the pipe. Being sure the pipe is in the proper flow direction, slide the end into the box and out through the combustion air pipe. Position the vent pipe so that the end is no more than 6" (152mm) below the box. The upper end should extend at least 3" (76mm) above the combustion air pipe. **NOTE: The double-wall vent pipe does not attach to the box. The installer must provide support.**

Follow the instructions in **FIGURE 12**, page 17 for connecting the double-wall pipe to the single-wall pipe or Category III vent pipe run. A taper-type reducer is required.

Seal the circumference of the pipe and the opening of the box with silicone sealant. Seal the area around the pipe completely.

7. On the outside, slide the combustion air inlet over the vent pipe and fasten the collar to the combustion air pipe with sheetmetal screws. See **FIGURE 23**. Seal the opening at the top between the vent pipe and the combustion air inlet with silicone sealant to prevent water leakage.

8. Attach the exhaust (vent) cap. See **FIGURE 23** and follow the illustrated instructions in **FIGURE 11**, page 16.

9. Attach the indoor combustion air pipe. Use sheetmetal screws to attach the single-wall combustion air pipe run to the collar on the concentric adapter box. Seal with tape or sealant. If using 7" pipe, install a taper type enlarger as illustrated in **FIGURE 14**, page 18.

FIGURE 23 - Install Combustion Air Inlet and Vent Terminal

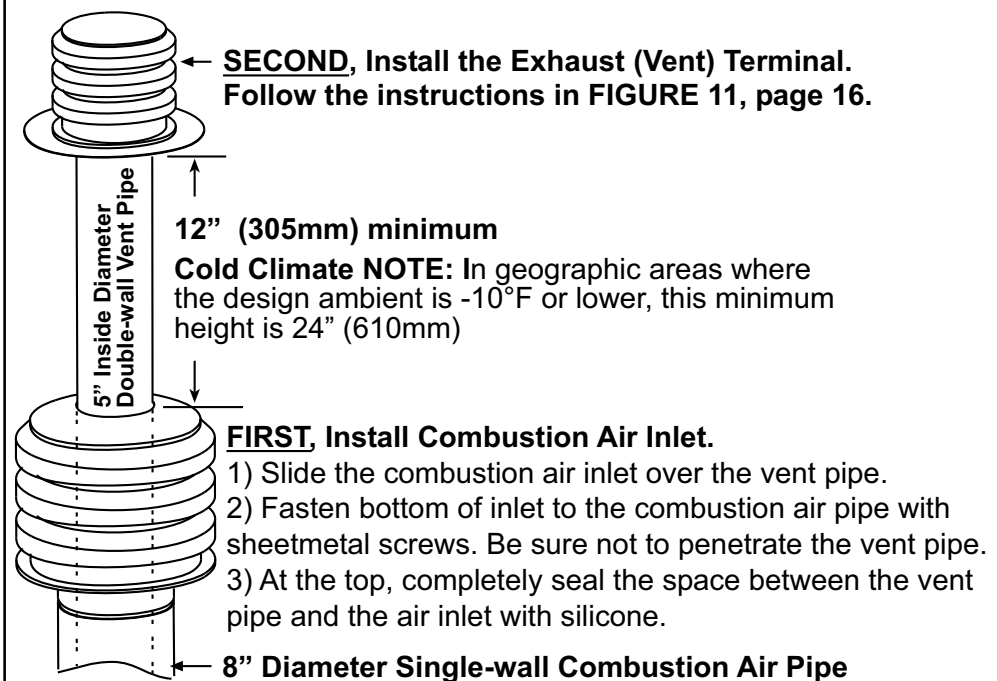

Installation of the vertical vent and combustion air system on your separated-combustion unit is complete. **Verify compliance with all venting installation requirements, pages 15-18, and FIGURE 24**

FIGURE 24 - Installation of Unit with Vertical Vent Terminal/Combustion Air Inlet (Option CC2)

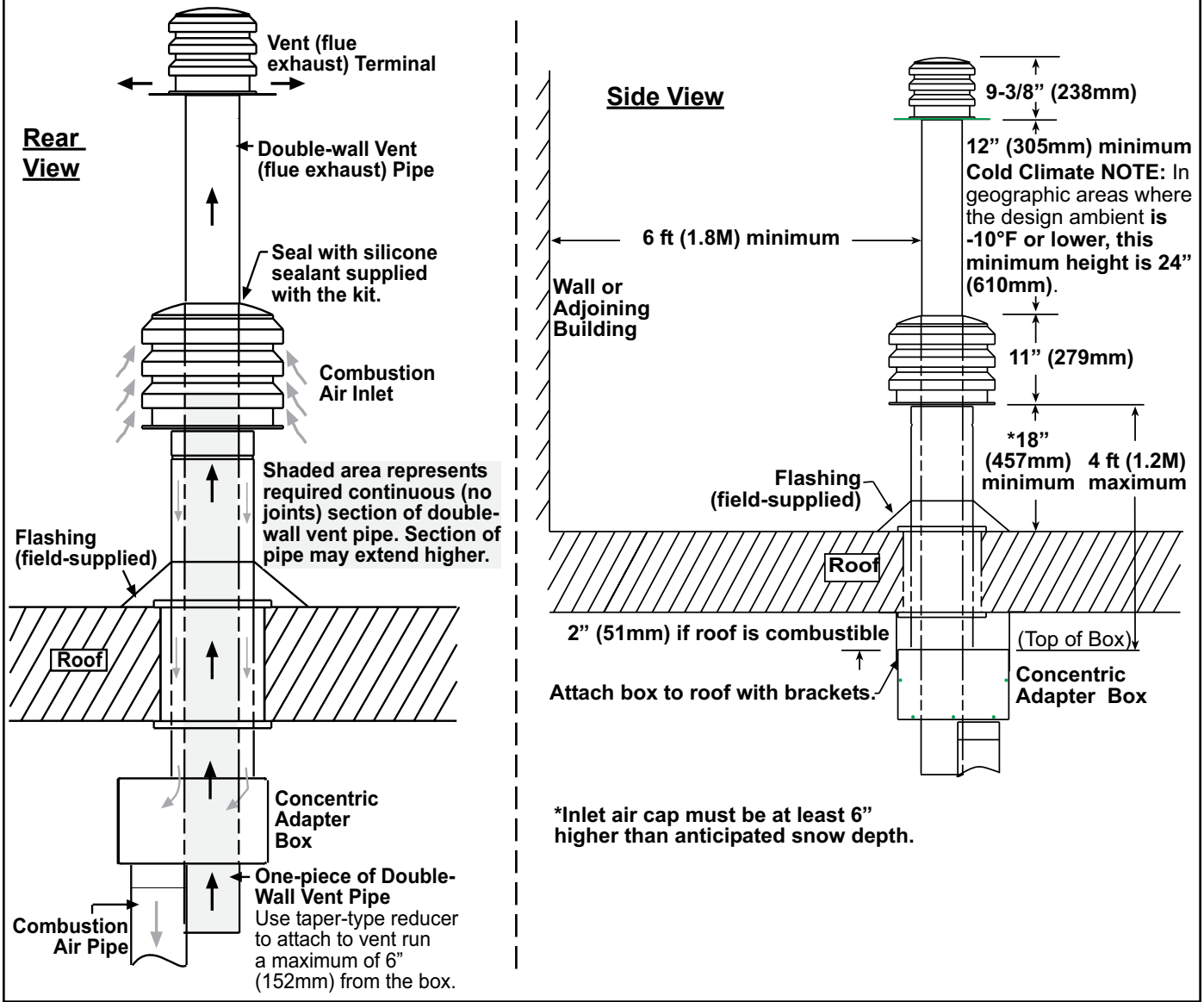

6.2.2 Venting Outdoor Power Vented Model RPBL

FIGURE 25 - Flue Outlet and Combustion Air Inlet - Model RPBL

The screened flue gas and combustion air openings are located on the side of each furnace section just above the control access panel (**FIGURE 25**).

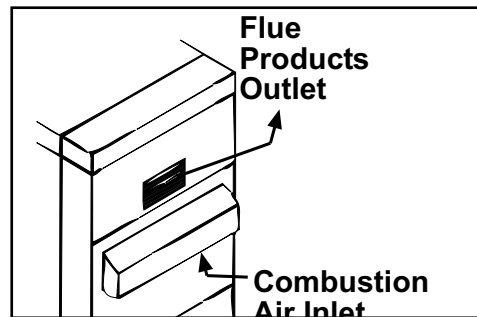

The positions of the openings discourage recirculation of combustion products and provide for furnace operation in all normal weather conditions.

Install a power-vented furnace so that the flue discharge is **not** directed at fresh air inlets.

Optional Vertical Flue Discharge (Option CC3) for Model RPBL

These power vented furnaces are certified with four feet (1.2M) of vertical pipe attached as shown in **FIGURES 26A and 26B**. The distance is measured from the top of the unit to the bottom of the vent cap. The option package includes the 5" vent cap, the adapter assembly and the seal plate. (One package is required for each furnace section.) The vent pipe and supports are field supplied. The straight pipe connecting the furnace to the 90° elbow must be at least 18" (457mm) in length.

6.0 Mechanical (cont'd)

6.2 Venting and Combustion Air (cont'd)

6.2.2 Venting Outdoor Power Vented Model RPBL (cont'd)

Optional vertical vent piping provides compliance with local codes that require either 10-ft (3M) horizontal or 4-ft (1.2M) vertical clearance between the flue outlet and fresh air intake of the heating system and/or the building.

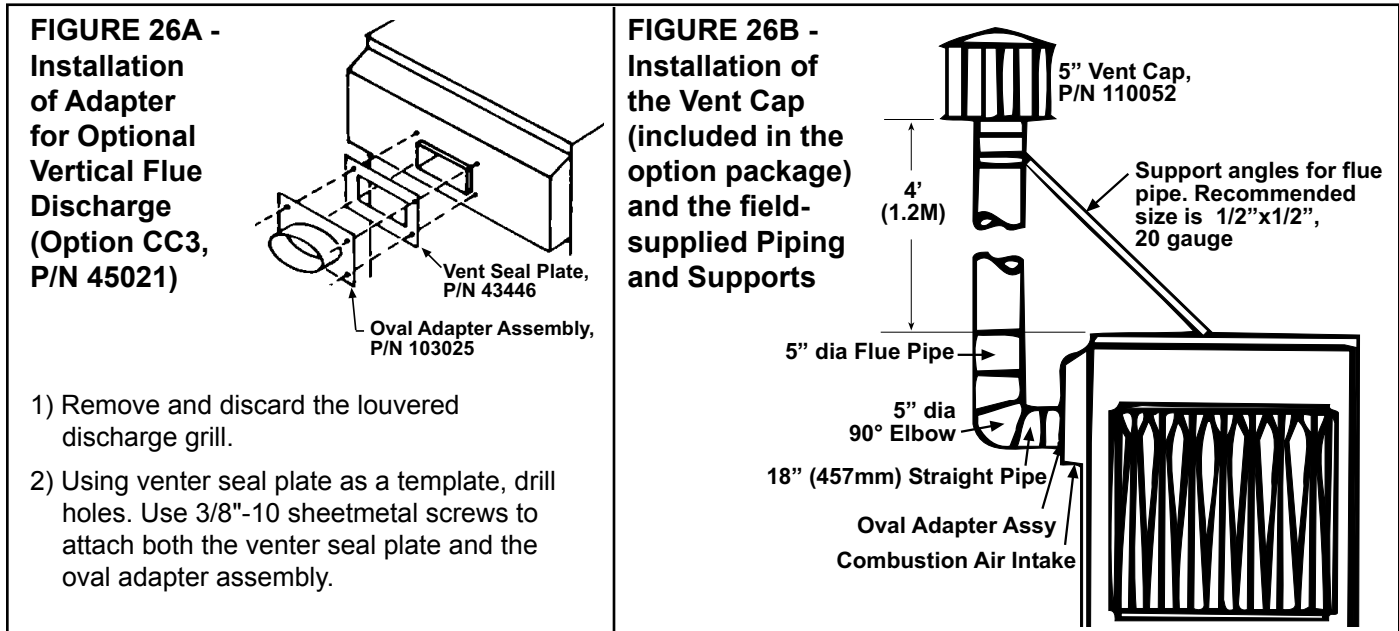

6.3 Unit Inlet Air

6.3.1 100% Outside Air Hood - Model RPBL

Outside air hood (Option AS2) is a weatherized, screened hood designed to be field assembled and installed around the horizontal inlet air opening of the blower cabinet. The air hood includes a louver assembly designed to help eliminate moisture from the inlet air. Complete installation instructions are packaged with the air hood option.

FIGURE 27 - Dimensions of Outside Air Hood, Option AS2

NOTE: Either a manufacturer designed optional air inlet hood as shown in **FIGURE 27** or an evaporative cooling module as shown in Paragraph 6.3.3 is required to ensure complete weather resistance.

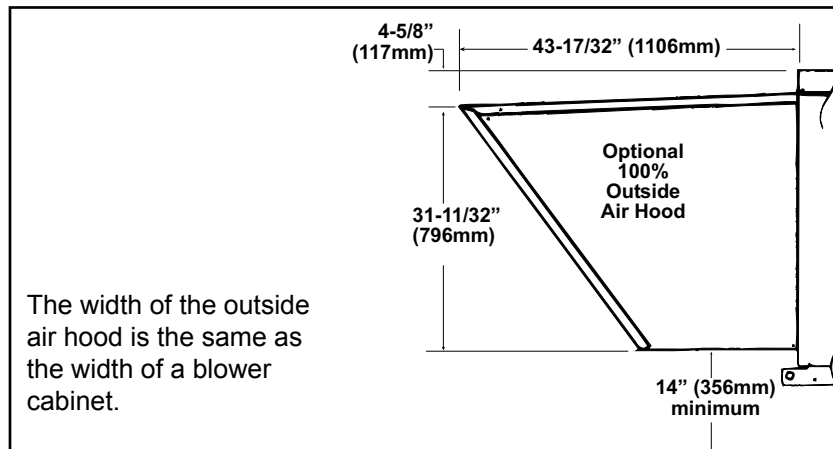

CAUTION: It is recommended that the inlet to the outside air hood **NOT** be facing into the prevailing wind. Allow 14" minimum clearance from the bottom of the air hood to the mounting surface.

Installation Instructions - 100% Outside Air Hood

Refer to **FIGURE 28**. All screw ends except those across the bottom should be inside the air hood.

To avoid possible damage, it is recommended that the outside air hood be installed after the system has been placed on the roof. The air hood should be installed before the heater is operated. Do not install the hood while the system (furnace or blower) is in operation.

1. Top Panel -- On the air inlet side of the blower cabinet, remove the factory-installed screws attaching the blower cabinet top. Slide the air hood top panel underneath the edge of the blower cabinet top. **The edge of the air**

hood top panel must be between the blower cabinet top and the end panel. Reinsert all of the sheetmetal screws.

2. Side Panels -- Slide the air hood right side panel into the groove in the blower cabinet end panel. Be sure that the side panel is underneath and to the inside of the air hood top panel. Attach to the blower cabinet and the air hood top using the required number of sheetmetal screws. Repeat with the left side panel.

3. Bottom Panel -- Position the air hood bottom panel so that it is to the **inside** of the two side panels and **above** the factory-installed support angle. Attach to the side panels.

If the bottom panel does not rest tightly against the support angle, follow these instructions to adjust the position of the support angle:

- a) Slightly loosen (do not remove the screws).
- b) Slide the support angle up so that it is against the bottom panel.
- c) Tighten the screws.

Attach the support angle to the air hood bottom panel. The bottom panel of the air hood and the support angle should be tight together; do not draw with the sheetmetal screws.

4. Louver Assembly -- With the intake screen toward the inside of the hood, position the pre-assembled vertical louver assembly in the inlet opening of the air hood. Using the remaining sheetmetal screws, attach the louver assembly to the air hood side panels using the holes provided.

FIGURE 28 - Assembly Drawing of Option AS2 Outside Air hood

RPBL	Top Panel	Bottom Panel	Louver Assy
400, 800, 1200	100232	100239	103778
500, 600	100230	100237	103776
700, 1050	100231	100238	103777

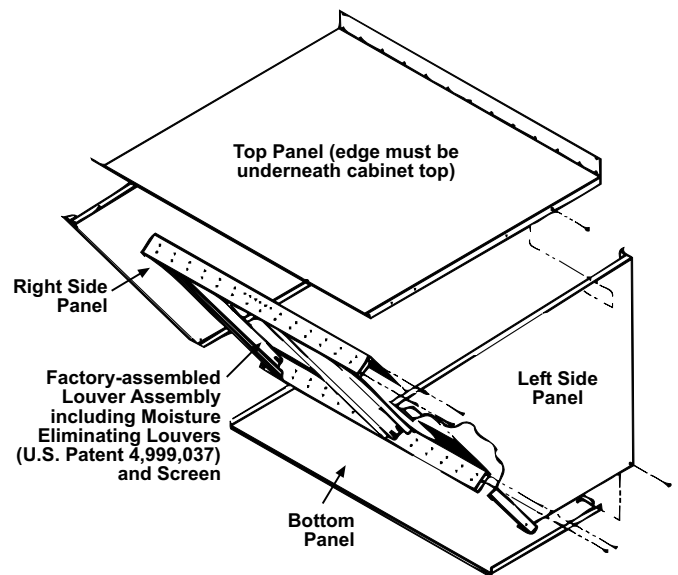

6.3.2 Screened Air Hood for 30% Outside Air Opening, Part of Inlet Air Options AR6 and AR7 - Model RPBL

The outside air hood included in the air inlet options that have a 30% outside air opening (Option AR6 or AR7) is shipped separately for field installation. Instructions are packaged with the air hood.

FIGURE 29 - Installation of Air Hood on Cabinets with 30% Outside Air Opening Options

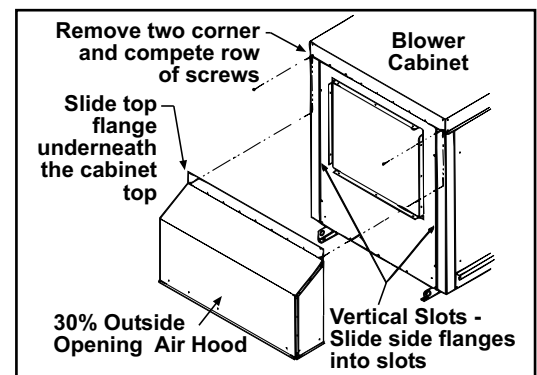

Installation Instructions - 30% Outside Air Hood (FIGURE 29)

1. On the inlet air side of the blower cabinet, remove the factory installed screws attaching the blower cabinet top.
2. Slide the air hood top flange underneath the lip of the blower cabinet top and the sides into the vertical slots. **The air hood flange must be between the blower cabinet top and the cabinet end panel.**
3. Reinsert all of the sheetmetal screws.

6.0 Mechanical (cont'd)

6.3 Unit Inlet Air (cont'd)

FIGURE 30A - Control Locations for 100% Outside Air and 100% Return Air Damper Options

6.3.3 Optional Dampers and Controls - RPBL and SSCBL

Damper controls are identified on the wiring diagram as AR Options.

The illustration in **FIGURE 30A** is intended to show location only of various air control accessories and does not represent suggested combinations of accessories. The illustration does not accurately depict the blower cabinet; control locations are approximately correct.

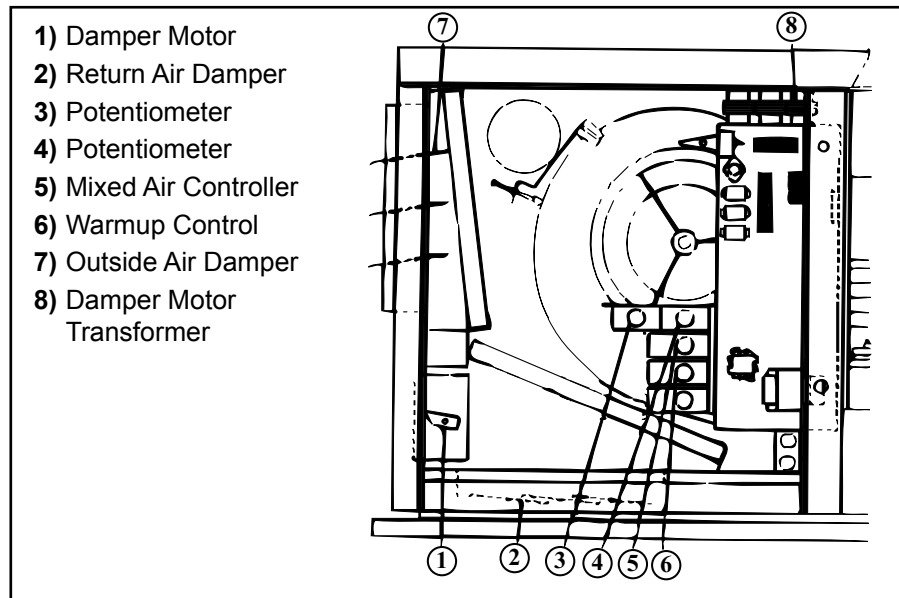

FIGURE 30B - Location of Controls for 30% Outside Air Hood and Damper Options (AR6 or AR7)

NOTE: See Paragraph 6.3.2.

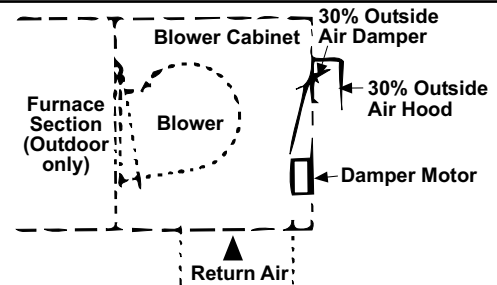
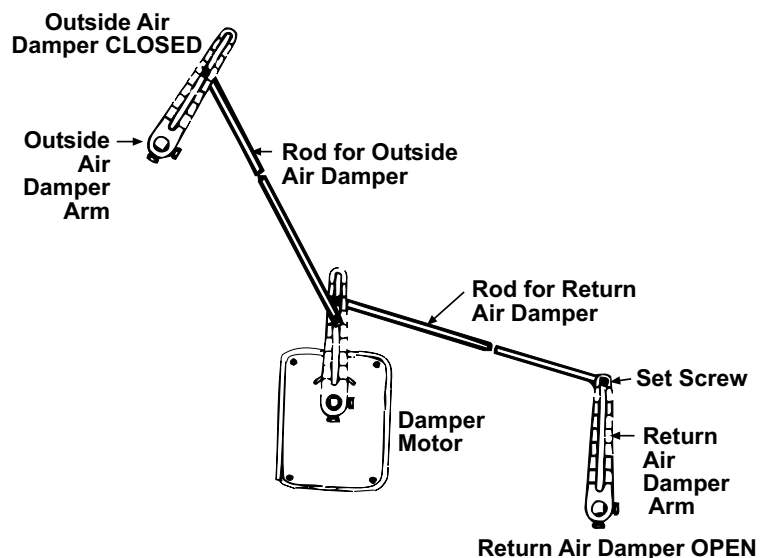

FIGURE 30C - Example of Outside Air and Return Air Damper Linkage

Inlet Air Damper Linkage -- When units are equipped with dampers, the dampers are closed during shipment. When there are **both** return air and outside air dampers, **the return damper linkage must be adjusted prior to use.**

1. Loosen the set screw on the return air damper rod at the damper arm.
2. Manually open the return air dampers. While the dampers are opening, the damper rod and arm will automatically move to their correct positions.
3. Tighten the set screw.



Pressure Null Switch (Used to control Outside Air Dampers in Option AR23)

The pressure null switch used in Option AR23 is a Dwyer #1640-0 with a range of .01-.20" w.c. It is shipped separately for field installation. Refer to the following paragraphs and the manufacturer's installation instructions included with the switch.

Description and Application - The pressure null switch is a diaphragm operated differential pressure switch used in makeup air applications to control building pressure.

It maintains a selected positive or negative pressure setpoint by changing the amount of outside air being introduced to the building through the modulating outside air dampers. As more pressure is required in the building, the pressure null switch activates the damper motor driving the outside air damper towards the full open position and the recirculated air damper towards the closed position. Conversely, as less pressure is required, the switch drives the dampers in the opposite direction.

Installation Instructions for Pressure Null Switch

1. Select an indoor location free from excessive vibration where oil or water will not drip onto the switch and where ambient temperature will be within a range of -30°F (dry air) to 110°F.
2. **Mount the switch with the diaphragm in a vertical plane.** The switch is position sensitive and is calibrated to operate properly when the diaphragm is vertical. Mount switch securely.
3. Connect the pressure taps on the top of the switch to sources of air pressure differential. Metal tubing with 1/4" O.D. is recommended, but any tubing system which will not unduly restrict the air flow may be used. To maintain a positive building pressure, vent the low pressure tap to the outdoors and allow the high pressure tap to monitor building pressure. To maintain a negative building pressure, reverse the functions of the high and low pressure taps. In either case, be sure that the outdoor vent is protected from the wind and screened from insects.
4. **Adjustment of the Switch** - The "HIGH" actuation point of the null switch is indicated on a calibrated scale secured to the transparent range screw enclosure. Building pressure is set by turning the adjustment screw. The "Low" actuation point is set by adjusting the span of the null by turning the span adjustment screw. The span range is .01" to .03" w.c.
5. See the wiring diagram included with the furnace to make electrical connections.

FIGURE 31 - Pressure Null Switch (used with Inlet Air Option AR23)

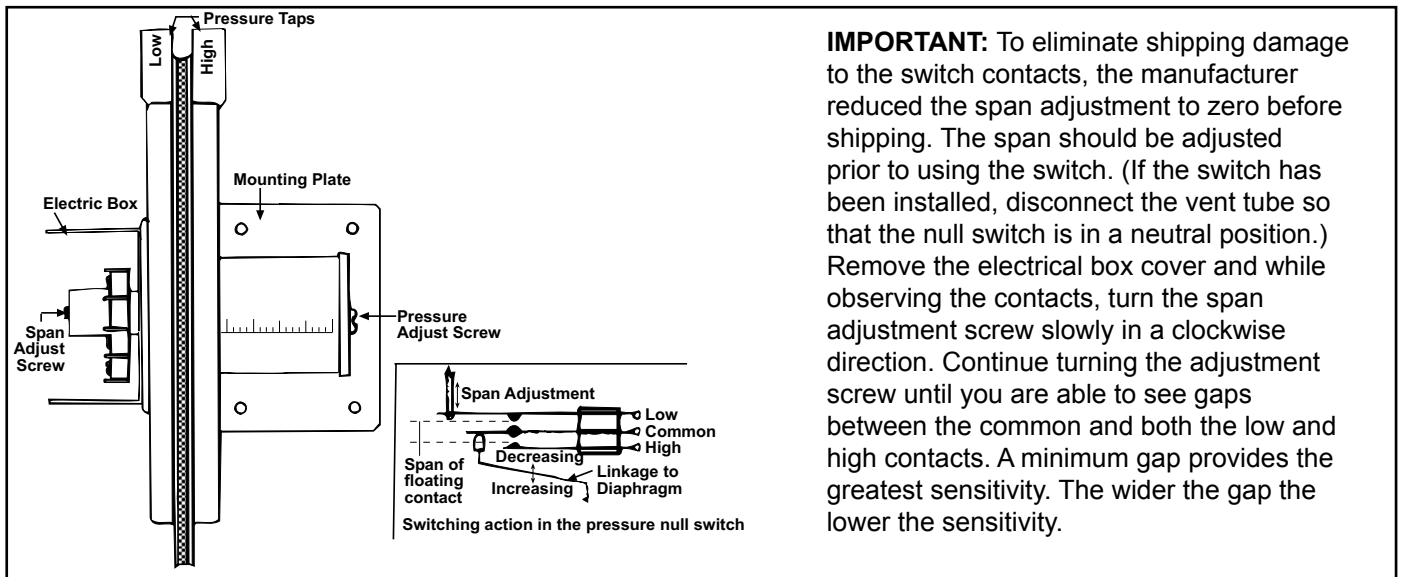

6.3.4 Optional Filter Rack and Filters - SSCBL and RPBL

Quantities and Sizes of Optional Filters

The system is equipped with a combination blower/filter cabinet. Filter rack and filters are optional equipment.

Filters are available in 2", disposable, permanent, or pleated disposable type.

Type/All 2"	SSCBL/RPBL 400; 800; 1200	SSCBL/RPBL 500; 600	SSCBL/RPBL 700; 1050
Disposable	(2) 16 x 16; (1) 16 x 25; (4) 12 x 25; (4) 12 x 30	(1) 16 x 25; (1) 16 x 20; (4) 12 x 20; (4) 12 x 25	(2) 16 x 25; (4) 12 x 30; (4) 12 x 20
Permanent	(2) 16 x 16; (8) 12 x 16; (1) 16 x 25; (4) 12 x 26	(1) 16 x 20; (4) 12 x 20; (1) 16 x 25; (4) 12 x 26	(2) 16 x 25; (8) 12 x 26
Pleated Disposable	(2) 16 x 16; (4) 12 x 25; (1) 16 x 25; (4) 12 x 32	(1) 16 x 20; (1) 16 x 25; (4) 12 x 20; (4) 12 x 25	(2) 16 x 25; (4) 12 x 32; (4) 12 x 20

6.0 Mechanical (cont'd)

6.3 Unit Inlet Air (cont'd) 6.3.4 Optional Filter Rack & Filters (cont'd)

FIGURE 32 - Filter Arrangements by Model and Size

Type of Filter	2"	*Average Efficiency	*Average Arrestance
Disposable	2"	Less than 20%	80%
Permanent	2"	Less than 20%	64% to 67%
Pleated Disposable	2"	30% to 35%	90% to 93%

*Tested in accordance with ASHRAE 52-76 Test Standard

Filter Airflow Range

Disposable.....	0 to 400 FPM
Pleated Disposable....	0 to 500 FPM
Permanent.....	0 to 600 FPM

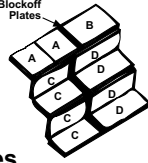
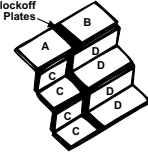
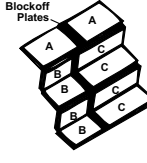
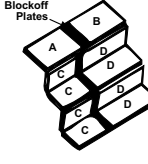
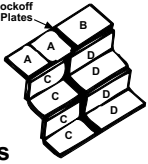
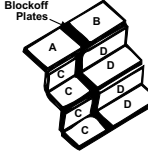
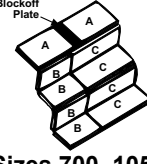
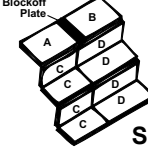
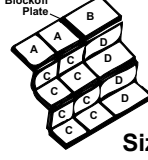
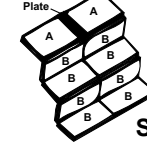
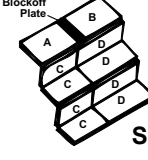
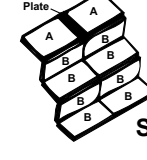
Filter Arrangements for 2" Disposable Filters (Option AW7)			
 <p>Sizes 400, 800, 1200</p>	A	16 x 16	 <p>Sizes 500, 600</p>
	B	12 x 25	
	C	12 x 25	
	D	12 x 30	
 <p>Sizes 700, 1050</p>	A	16 x 25	 <p>Sizes 500, 600</p>
	B	12 x 20	
	C	12 x 20	
	D	12 x 25	
 <p>Sizes 400, 800, 1200</p>	A	16 x 16	 <p>Sizes 500, 600</p>
	B	16 x 25	
	C	12 x 25	
	D	12 x 32	
 <p>Sizes 700, 1050</p>	A	16 x 25	 <p>Sizes 500, 600</p>
	B	12 x 20	
	C	12 x 32	
	D	12 x 25	
 <p>Sizes 400, 800, 1200</p>	A	16 x 20	 <p>Sizes 700, 1050</p>
	B	16 x 25	
	C	12 x 20	
	D	12 x 26	
 <p>Sizes 500, 600</p>	A	16 x 25	 <p>Sizes 700, 1050</p>
	B	16 x 25	
	C	12 x 20	
	D	12 x 26	

Filter Pressure Drops

SSCBL or RPBL	CFM	Filter Pressure Drops (" w.c.)			
		Disposable	Permanent	Pleated	
400 1 Size 400 Furnace and 1 BL Blower	3300	0.02	0.03	0.03	
	4000	0.03	0.05	0.06	
	5000	0.04	0.08	0.10	
	6000	0.06	0.12	0.14	
	7000	0.08	0.16	0.19	
	8000	0.10	0.21	0.25	
	9000	0.13	0.26	0.31	
	10000	N/A	0.33	0.39	
	11000	N/A	0.40	0.47	
	12000	N/A	0.48	0.56	
	13000	N/A	0.56	N/A	
	14000	N/A	0.65	N/A	
	500, 600 2 Size 250 or 300 Furnaces and 1 BL Blower	3700	0.04	0.04	0.06
		4000	0.05	0.06	0.08
5000		0.08	0.10	0.12	
6000		0.12	0.14	0.17	
7000		0.16	0.20	0.23	
8000		N/A	0.25	0.31	
9000		N/A	0.31	0.40	
10000		N/A	0.39	N/A	
11000		N/A	0.46	N/A	
12500		N/A	0.60	N/A	
700 2 Size 350 Furnaces and 1 BL Blower	5200	0.06	0.08	0.10	
	6000	0.06	0.10	0.15	
	7000	0.08	0.14	0.20	
	8000	0.10	0.18	0.27	
	9000	N/A	0.24	0.33	
	10000	N/A	0.30	0.41	
	11000	N/A	0.36	N/A	
	12000	N/A	0.42	N/A	
800 2 Size 400 Furnaces and 1 BL Blower	5900	0.05	0.10	0.12	
	6000	0.06	0.12	0.14	
	7000	0.08	0.16	0.19	
	8000	0.10	0.21	0.25	
	9000	0.13	0.26	0.31	
	10000	N/A	0.33	0.39	
	11000	N/A	0.40	0.47	
	12000	N/A	0.48	0.56	
	13000	N/A	0.56	N/A	
	1050 3 Size 350 Furnaces and 1 BL Blower	6500	0.06	0.10	0.08
		7000	0.08	0.14	0.12
		8000	0.10	0.18	0.16
		9000	N/A	0.24	0.2
10000		N/A	0.30	0.24	
11000		N/A	0.36	N/A	
1200 3 Size 400 Furnaces and 1 BL Blower	7400	0.08	0.16	0.19	
	8000	0.10	0.21	0.25	
	9000	0.13	0.26	0.31	
	10000	N/A	0.33	0.39	
	11000	N/A	0.40	0.47	
	12000	N/A	0.48	0.56	
13000	N/A	0.56	N/A		

Optional Dirty Filter Switch

The optional dirty filter pressure switch is used to provide warning to the user by energizing an indicator light on an optional remote console. The light indicates that the filters are in need of cleaning or changing. The adjustable, single-pole/normally open differential switch closes when an increase in pressure differential above the setpoint, is sensed across the filter bank.

This switch is located in the furnace section. See page 43, **FIGURE 46**, Item 17. After the unit is started, before continuous operation, the dirty filter switch must be set.

Instructions for Setting Dirty Filter Switch (FIGURE 33)

With clean filters in place, blower doors closed, and blower in operation, decrease the pressure setting by adjusting the set screw on the switch clockwise until the filter light is energized or the screw is bottomed out. At that point, adjust the set screw three full turns counterclockwise or until the screw is top-ended. At that setpoint the filter light will be activated at approximately 50% filter blockage.

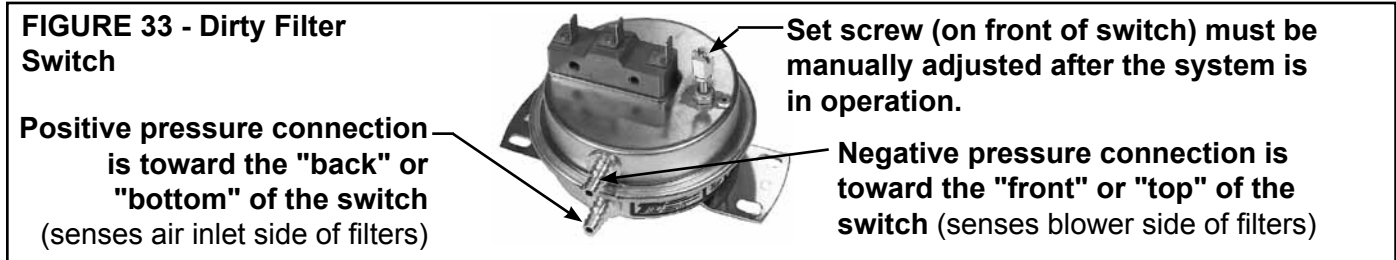

6.3.5 Optional Evaporative Cooling Module - Applies to Model RPBL

Evaporative cooling provides excellent comfort cooling at low initial equipment and installation costs and low operating and maintenance costs. Direct evaporative cooling works solely on the principle that water in direct contact with a moving airstream will eventually evaporate if the droplets have long enough exposure. This evaporative cooling module uses wetted rigid cellulose or glass fiber media to retain water in order to allow time for evaporation.

FIGURE 34 - Optional Evaporative Cooling Module is factory-assembled for field attachment to the blower cabinet (duct and base are shipped knocked down for field assembly)

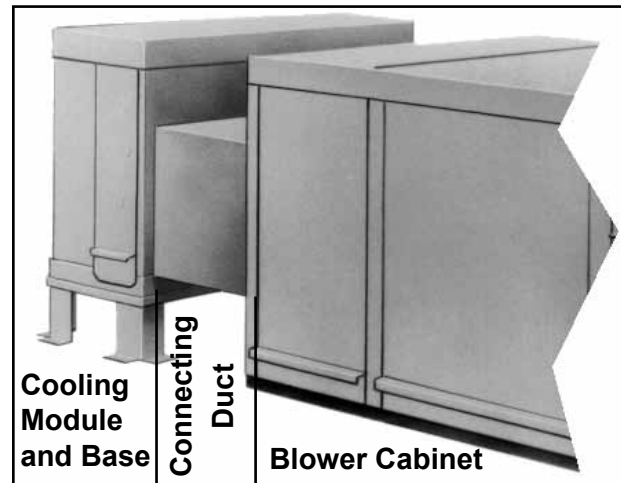

The evaporative cooling module for these systems is factory assembled but is not attached to the blower cabinet at the factory. It is shipped separately for field attachment to the system blower cabinet. The base support for the cooling module and the transitional ductwork between the cooling module and the blower cabinet inlet are shipped separately and must be field assembled and installed. Complete installation instructions including water and electrical connections are included with the evaporative cooling module package.

Included in the cooling module installation booklet is a preparation checklist. All items in that checklist should be consulted prior to beginning installation of the optional evaporative cooling module. Four of those items are listed below.

- Make certain the supporting platform is capable of handling the additional load of a full cooling module reservoir.

Weights of Evaporative Cooling Module - w/Wet Media & Full Reservoir (lbs.)

Module with 12" rigid cellulose media (Opt AS4) 431 lbs

Module with 12" rigid glass fiber media (Opt AS8) 514 lbs

6.0 Mechanical (cont'd)

6.3 Unit Inlet Air (cont'd)

6.3.5 Optional Evaporative Cooling Module - Applies to Model RPBL (cont'd)

- Make certain the surface is level and free of debris where cooling module will be mounted.
- Provide a weather-resistant, solid wood or metal base under legs of cooling module base.

FIGURE 35 - Field-Assembled Base for Optional Evaporative Cooling Module

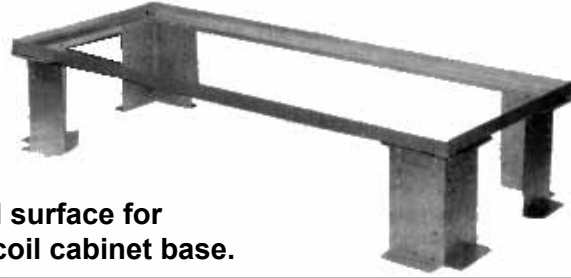

Provide solid, level surface for mounting cooling coil cabinet base.

- Make certain that there will be adequate clearance between the bottom of the reservoir and the mounting surface to allow for drain and overflow pipe connections.

The optional evaporative cooling module is equipped with high efficiency pad media of either 12" rigid cellulose (**Option AS4**) or 12" rigid glass fiber (**Option AS6**). 12" media provides 90% efficiency. Efficiency values are stated at maximum allowable CFM without the addition of a moisture elimination pad with an inlet dry bulb temperature of 95°F and inlet wet bulb temperature of 65°F. The evaporative cooling efficiency is a function of inlet temperature and of face velocity through the media. The stated cooling efficiency will rise with the decrease of CFM and the increase of inlet temperature. Moisture elimination pads (Option ASA1) may be used on all units but are required on units with over 11,200 CFM (950 FPM). Instructions for field installation of the optional moisture elimination pad are included with the cooling module.

WARNING

Pump must never be operated without water in the reservoir. See Hazard Levels, page 2.

WARNING

Disconnect all power to the unit before doing any maintenance. Failure to do so can cause electrical shock, personal injury or death.

Evaporative Cooling Module Maintenance

NOTE: For troubleshooting information about the optional evaporative cooling module, refer to Form I-OPT-EC, installation manual shipped with the evaporative cooling module.

Instructions for Replacing Evaporative Cooling Media

Media -- Over time, excessive amounts of mineral deposits will begin to build up on the media. Annually, scale and dirt should be washed off the entering surface of the media. Remove the pad retainers and screen (See Steps 1-3 and 6-8 of Media Replacement Instructions). Clean the media using a garden hose, mild soap, and a **soft** bristled brush. When the media becomes too clogged with mineral deposits and dirt that cannot be cleaned, the pads should be replaced. The average pad life expectancy is approximately three cooling seasons.

Select the correct replacement part numbers and order replacement media pads from your distributor. Follow the instructions below and remove and replace pads as shown in **FIGURES 36 and 37**.

1. Remove the three sheetmetal screws that hold the top pad retainer in place. Release the top pad retainer from the cooling module.
2. Remove the three sheetmetal screws that hold the bottom pad retainer in place. Release bottom pad retainer from the cooling module.
3. Disengage the screen retainers from the sides of the media.
4. Disengage inlet screen from media pads and remove.
5. Slide all media pads horizontally away from the cooling module until clear of bottom reservoir pan. Dispose of properly.
6. Replace media by sliding media pads over both support rails until back stop is encountered. Media **must** be placed as shown in **FIGURE 37**.
7. Center screen on the incoming air side of the media.

FIGURE 36 - Removal and Replacement of Evaporative Cooling Module Media

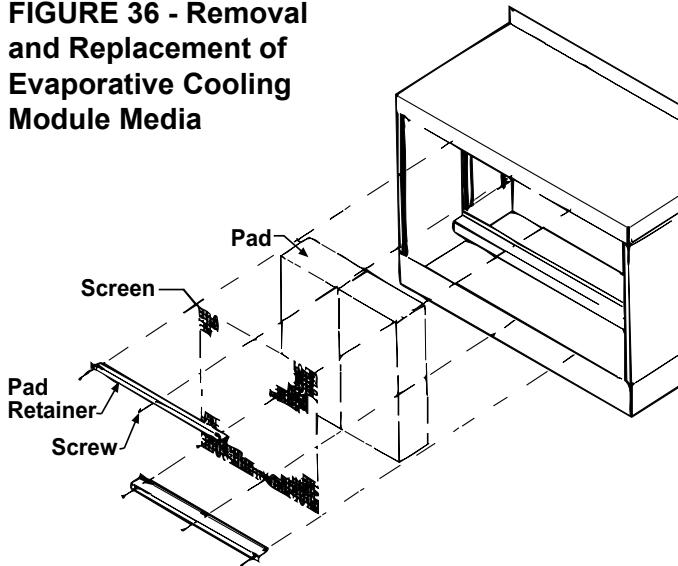

Media Pad Sizes (inches)	Qty	Replacement Part No. (each)	
		Rigid Cellulose	Rigid Glass Fiber
48 x 12	4	107194	107201
48 x 8-5/8	1	107195	107202

FIGURE 37 - Media must be installed with 45° angle sloping downward toward the incoming outside air.

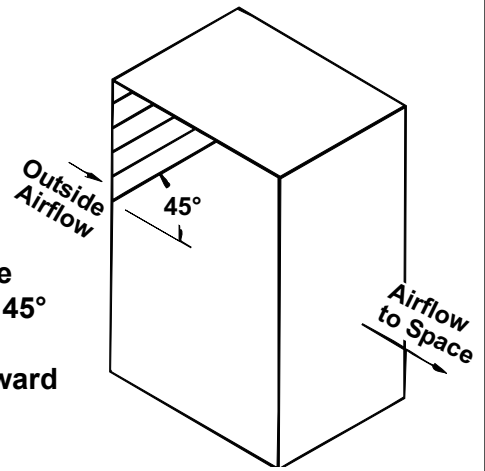

IMPORTANT: The media is made up of two different sheets of cooling material. Each sheet has its own unique angle. When replacing the cooling media, **BE CERTAIN** that the 45° angle slopes downward toward the incoming outside air (as illustrated above). If the media is not installed properly, water blowoff from the media pads will occur.

8. Replace the two side screen retainers by fitting them between the side of the media pad and the side of the cooling module. The retainers should fit snugly, pinching the screen against the media pads.
9. Replace the bottom pad retainer by securing the retainer between the pad and the reservoir pan. Fasten with the three sheetmetal screws removed in Step 2.
10. Replace the top pad retainer by securing the retainer between the pad and top of the cooling module. Fasten with the three sheetmetal screws removed in Step 1.

Water Feed Line and Distribution Piping – Annually, the water supply line and the water distribution line (either PVC pipe or water sock) should be flushed of debris and contaminants.

1. Remove the media pads following the instructions above.
2. Remove the water feed line from the downstream side of the ball valve and unscrew the water bleed line barbed hose fitting.
3. Force a fresh water supply up through the water inlet hose and thoroughly flush the distribution line.
4. Re-assemble, being careful to install media with air flow direction as shown in **FIGURE 37**.

Water Pump and Inlet Basket Screen (Does not apply to module with optional timed metering system.) – Annually, the pump and inlet basket should be removed, disassembled and cleaned.

WARNING

Do not expose pump motor or any part of the electrical box to water. Evaporative cooling pump is NOT submersible.

1. Disconnect the power supply to the unit.
2. Remove the junction box door and disconnect the two power supply wires from the terminal block inside the junction box.
3. Disconnect the water feed line hose from the upstream side of the ball valve.
4. Unscrew the four sheetmetal screws holding the junction box to the cooling module. Remove the junction box-pump-float switch assembly.
5. Dislodge the inlet basket screen from the pump and clean any buildup of debris and dirt. Carefully remove the base cover plate from the bottom of the pump.

6.0 Mechanical (cont'd)

6.3 Unit Inlet Air (cont'd)

FIGURE 38 - Remove Junction Box, Pump and Float Switch as an Assembly

(NOTE: Applies to evaporative cooling module with float and pump control system only. Depending on date of manufacture, actual assembly may not appear exactly as in the photo.)

6.3.5 Optional Evaporative Cooling Module - RPBL (cont'd)

Using a mild soap solution, wash all deposits from the inside of the pump and remove all debris from the impeller.

6. Reassemble the pump. Replace the parts in exact reverse order, being careful that everything is returned to its proper position.

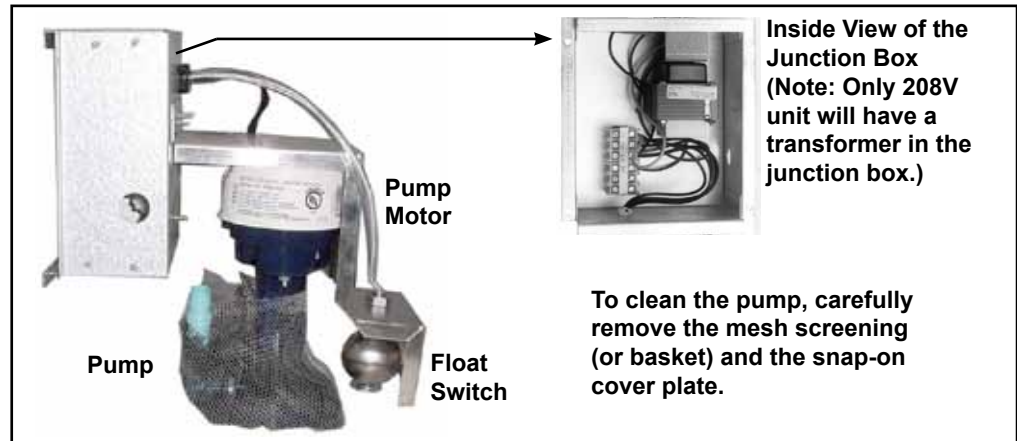

6.3.6 Cooling Coil Cabinet, Option AU - SSCBL and RPBL

FIGURE 39 - Optional Cooling Coil Cabinet is shipped separately for field attachment.

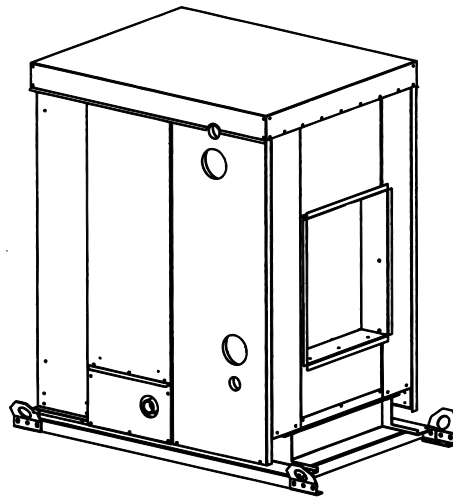

The optional cooling coil cabinet is shipped separately for attachment in the field. The cabinet includes either a chilled water or a refrigerant (DX) air conditioning coil. Cabinets alone have horizontal discharge but may have an attached downturn plenum for vertical discharge. If the downturn plenum is equipped with discharge dampers, field wiring including drilling holes and running wires is required. Cooling coil cabinet dimensions are on page 7.

(NOTE: If the system is being installed on an indoor Model SSCBL, consult the factory regarding installation.)

WARNINGS

Do NOT attach the cooling coil cabinet before lifting the packaged blower/furnace system into position. Lift the cooling coil cabinet separately. Do NOT attach the cooling coil cabinet while the furnace is in operation.

Using the parts shipped inside the cooling coil cabinet (see list below), follow the instructions to connect the coil cabinet to the furnace. In addition to normally required tools, a driver extension, a hammer, and bar or short length of 2x4 will be required. Silicone caulking must be field-supplied.

Factory-Supplied Parts for Attaching Optional Cooling Coil Cabinet

Description	Qty	400	500, 600	700	800	1050	1200
Top/Bottom Duct Connectors	2	106340, 47"	106338, 36"	106339, 41-1/2"	106340, 47"	106339, 41-1/2"	106340, 47"
Side Duct Connectors. 19-1/2"	2	106395	106395	106395	106395	106395	106395
#14 x 3/4" long Sheetmetal Screws	8	105171	105171	105171	105171	105171	105171
Left Side Filler Panel	1	172357	172357	172357	172357	172357	172357
Right Side Filler Panel	1	172358	172358	172358	172358	172358	172358
Top Filler Panel	1	172364	172362	172363	172364	172363	172364
Insulation - 1" x 42" x 9"	2	172546	172546	172546	172546	172546	172546
#10 x 1/2" long Sheetmetal Screws	>	(26) 11813	(24) 11813	(25) 11813	(26) 11813	(25) 11813	(26) 11813
Rubber Gasket Strip	1	106310	103608	103609	103610	103609	103610
3/32" x 1-1/8" x		64-7/8"	53-7/8"	59-3/8"	64-7/8"	59-3/8"	64-7/8"

Instructions for Lifting and Attaching Cabinet
 (NOTE: If suspending cabinet, consult factory.)

1. **After** the blower/furnace packaged system is in place on the roof curb or mounting rails, use a 9/16" wrench or socket to remove the lifting lugs that are on the discharge end of the system.
2. Lift the cooling coil cabinet and position it with the inlet side next to the discharge opening of the furnace. Remove the lifting lugs that are on the cooling coil cabinet.
3. Slide the cooling coil cabinet so that the duct flanges of the furnace and the cooling coil cabinet butt together (**See FIGURE 40A**).
4. **Join the Duct Flanges**
 - a) Use the four "U" shaped duct connector pieces and the 3/4" screws to join the duct flanges. Attach one of the 19-1/2" (495mm) long side connectors to both the top and bottom duct connectors, being sure that the "U" in the metal is open to the inside. (**See FIGURE 40B**.)

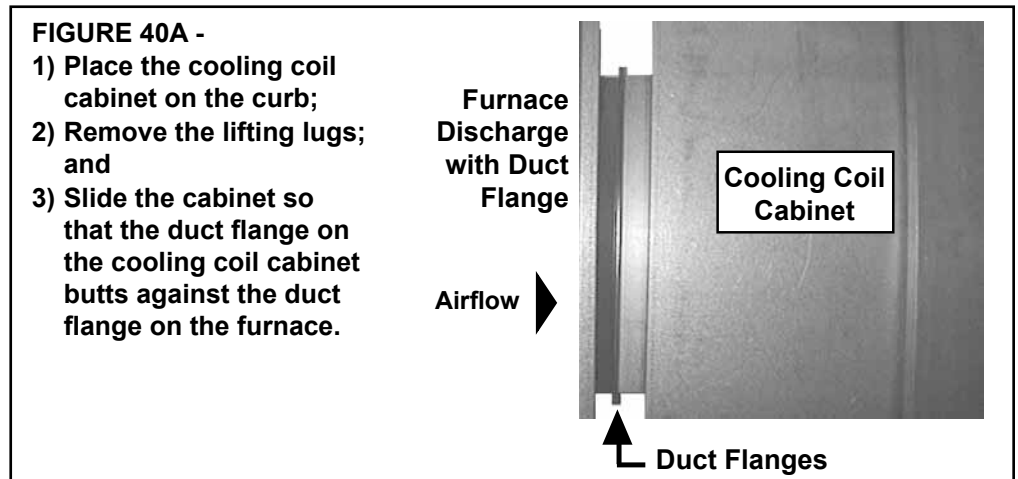
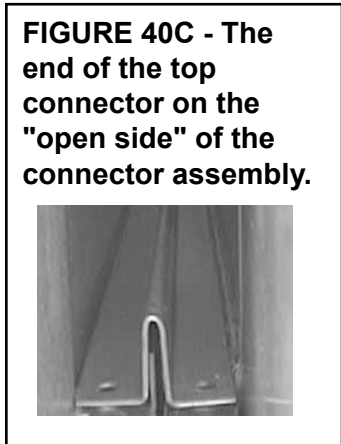
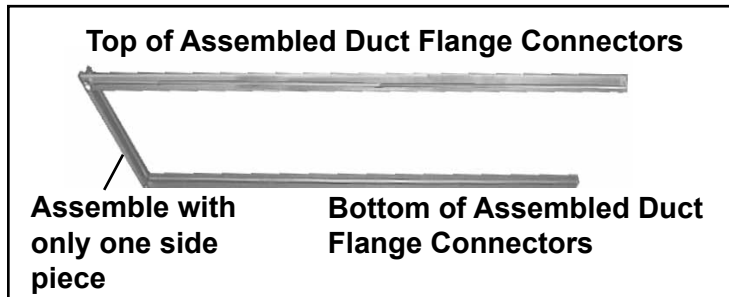

FIGURE 40B - Assemble top, bottom, and one side of the duct connector pieces using the 3/4" sheetmetal screws



- b) Position the assembled connectors so that the screw holes will be in the *top* piece at the open side (**See FIGURE 40C**). In this position, insert the assembled top and bottom connectors into the space between the furnace and the cooling coil cabinet.
 Tap with a hammer, first on the side, then on the top, and last on the bottom of the assembled duct connector until it is seated over both duct flanges.
 - c) Position the remaining side connector. Use a driver extension to insert the screws that attach the side connector to the top and bottom connectors. **See FIGURE 40D.**

5. Wiring Instructions - Apply to Downturn Plenum Cabinet with Optional Discharge Dampers Only - If installing an Option AU12 or AU14 cooling coil cabinet with a downturn plenum cabinet equipped with optional discharge dampers, the damper motor wires must be connected to the terminal blocks in the furnace electrical compartment. If the coil cabinet being installed does not include a downturn plenum with a discharge damper, skip Step 5 and proceed to Step 6.

- a) Drill three 7/8" holes as instructed below. Be sure all holes are free of burrs.

First Hole:

 - 1) Remove the control side door on the discharge plenum.
 - 2) Locate the discharge damper motor. Connected to the motor are three wires in lengths adequate to reach the furnace section.

FIGURE 40D - Position the remaining side connector over the duct flanges. Attach to the top and bottom connectors with 3/4" screws creating a "U" shaped rectangular frame that joins the duct flanges on all four sides.



Top screws should be vertical.

Bottom screws should be horizontal.

Instructions for Lifting and Attaching Coil Cabinet (cont'd)

3) Refer to **FIGURE 40E**. On the leg of the downturn plenum next to the cooling coil cabinet locate the mounting screw illustrated. Measure up 6" (152mm). At same centerline as the screw, drill the first 7/8" hole.

Second Hole:

1) Remove the cooling coil access panel(s).
 2) Locate the coil blockoff plate. Measure up 4" (102mm) from the bottom of the blockoff plate. At that location, find the center point of the blockoff plate and drill a 7/8" hole. The hole should be approximately even with the hole drilled in the downturn plenum leg.

Third Hole:

On the cabinet leg on the entering air side of the cooling coil cabinet, measure up 10" (254mm) from the bottom pan. At that height, measure in 4" (102mm) from the edge and drill a 7/8" hole.

b) On the outside of the furnace section (where the flanges were joined in Step 4), locate the three hole plugs. Remove the center hole plug exposing a 7/8" hole in the cabinet leg. See **FIGURE 40F**.

FIGURE 40E

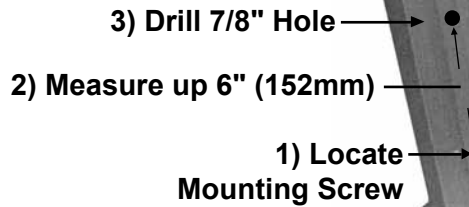

FIGURE 34F

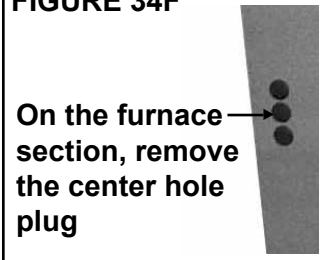
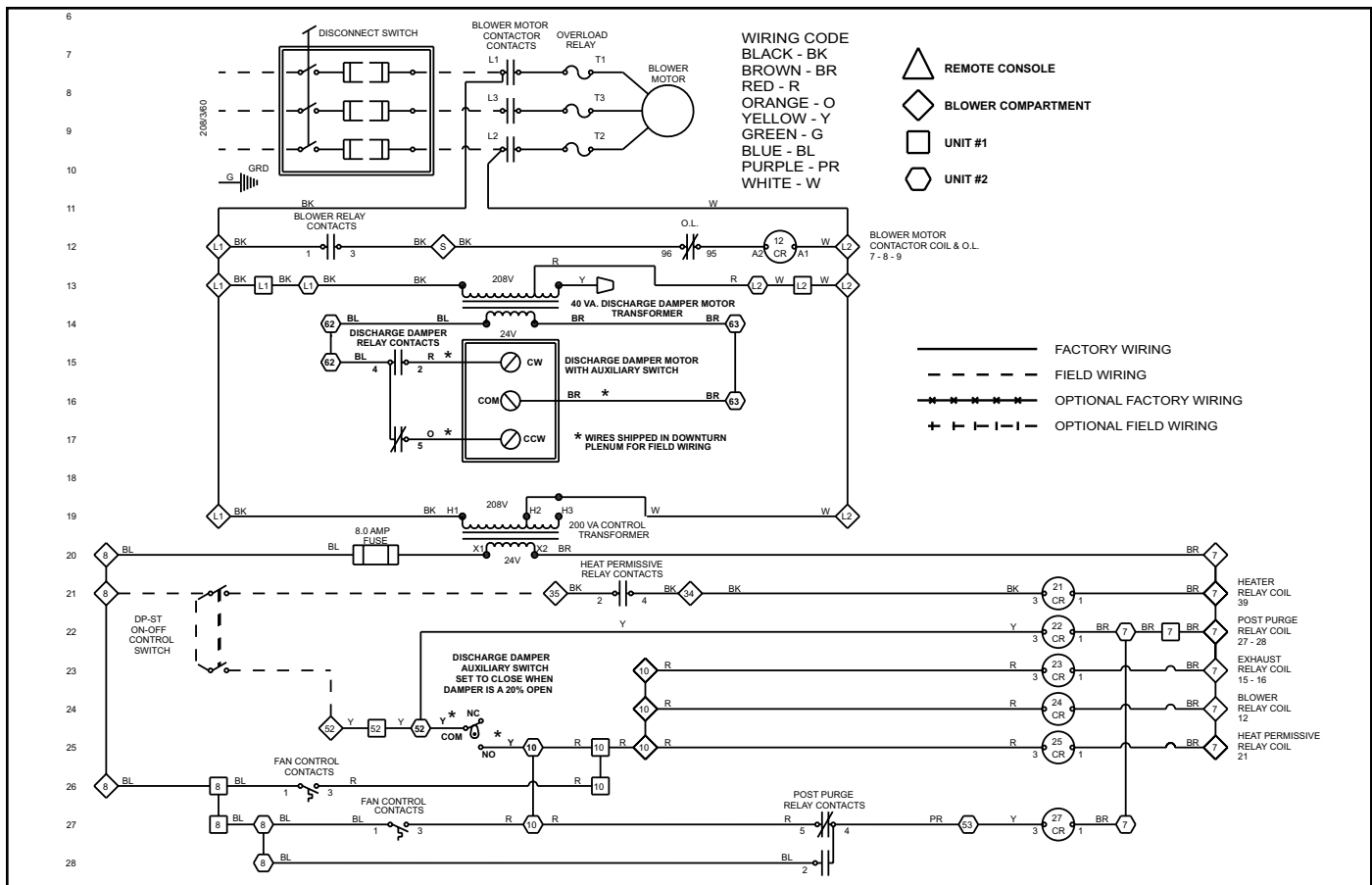

FIGURE 40G - Sample of a Partial Wiring Diagram showing Typical Field-Wiring Connections for Optional Discharge Damper



6.3.6 Optional Cooling Coil Cabinet, Option AU (cont'd)

- c) Run the wires attached to the damper motor **1)** out through the hole in the discharge plenum leg into the cooling coil cabinet, **2)** through the blockoff plate, across the coil cabinet, **3)** out through the hole in the cooling coil cabinet leg, and **4)** into the furnace section.
- d) On the bottom of the electrical box in the furnace section, remove the hole plug that is below the terminal blocks. Route the damper motor wires up through the hole and into the electrical box. Attach according to the connections on the wiring diagram. Refer to sample in **FIGURE 40G**.

6. Prepare Cabinets to Install Filler Panels (See **FIGURE 40H**.)

- a) At the side corners of both the cooling coil cabinet and the furnace, remove the factory-installed screws that attach the cabinet tops.
- b) Across the edge of the cooling coil cabinet, remove the row of screws that attach the top.

FIGURE 40H - To install side and top filler panels, remove screws from top corners of both cabinets and the entire row across the cooling coil cabinet.

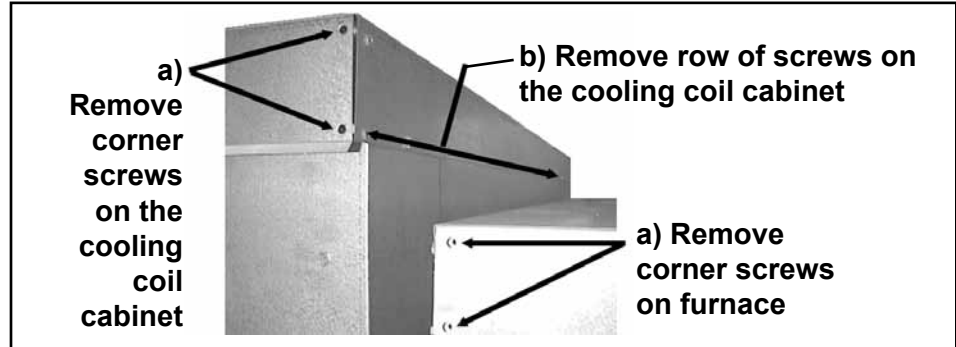

7. Install the Cabinet Side Filler Panels (See **FIGURE 40J**.)

Place a piece of the supplied insulation against the inner panel of the cooling coil cabinet. Slide the filler panel into place and attach with 1/2" sheetmetal screws. Repeat on the other side. **NOTE:** It may be easier to slide the filler panels in place with the door panels removed.

FIGURE 40J - Side Filler Panel Installed

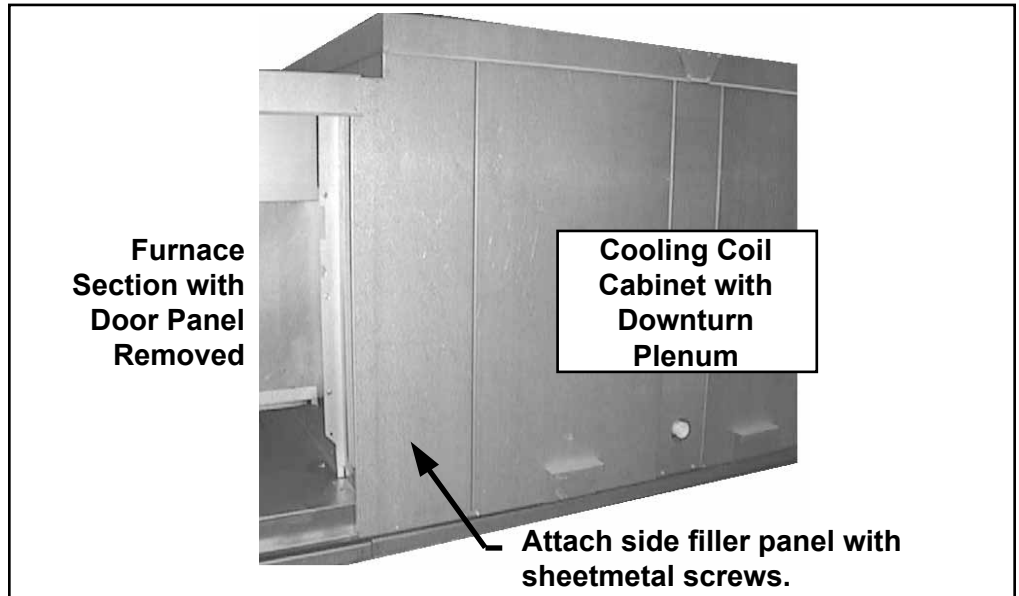

8. Install the Cabinet Top Filler Panel (See **FIGURE 40K**)

- a) Remove the backing from the gasket strip, and adhere it along the edge of the bottom of the top filler panel.
- b) Slide the filler panel underneath the edge of the cooling coil cabinet top (**NOTE:** The edge of the top panel may have to be pulled out slightly to slide the panel underneath.) The **filler panel must be between the cooling coil cabinet top and end panel** to prevent water from leaking into the cabinet. Attach with 1/2" screws.

9. Reinsert Screws and Apply Caulking

- a) Reinsert any remaining screws removed in Step 6. Check for gaps between the top and side filler panels; apply caulking as needed.
- b) Apply silicone caulking where the cooling cabinet curb cap meets the furnace curb cap.

6.0 Mechanical (cont'd)

6.3 Unit Inlet Air (cont'd)

6.3.6 Optional Cooling Coil Cabinet, Option AU (cont'd)

FIGURE 40K - Top Filler Panel Installed

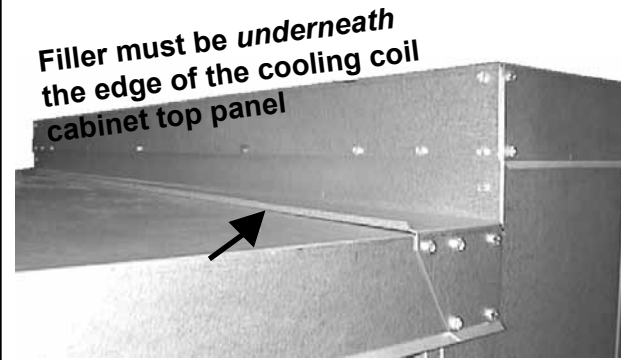

Before the top filler panel is attached, remove the backing and adhere the gasket strip along the bottom of the outside edge so that any gaps between the top filler panel and the top panel of the furnace section are sealed.

10. The cooling coil cabinet is installed. Follow the instructions provided by the cooling coil manufacturer to make cooling coil connections.

Cooling Coil Maintenance

The cooling coil cabinet is designed with easily removable panels on both sides of the cabinet to provide access for inspection and cleaning. Inspect the coil during routine maintenance and whenever the filters are changed. Check the cooling coil for build up of debris; clean as required.

6.4 Duct Connections - SSCBL and RPBL

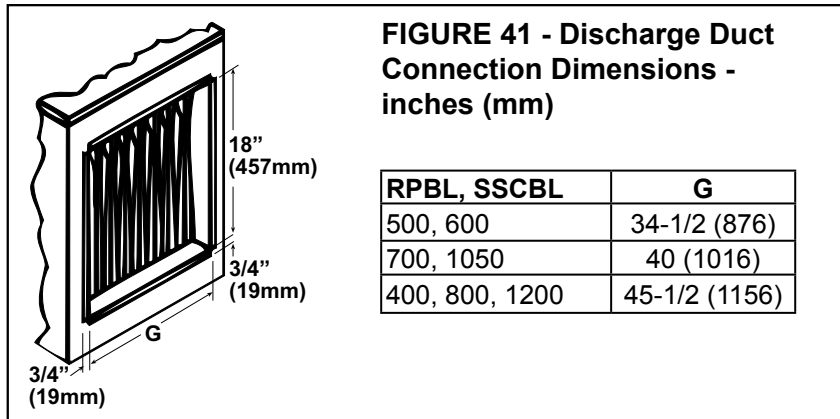

Requirements and Suggestions for Connecting and Installing Ducts

- **Type of Ductwork** - The type of duct installation to be used depends in part on the type of construction of the roof (whether wood joist, steelbar joist, steel truss, precast concrete) and the ceiling (whether hung, flush, etc.).
- **Ductwork Material** - Rectangular duct should be constructed of not lighter than No. 26 U.S. gauge galvanized iron or No. 24 B & S gauge aluminum.
- **Ductwork Structure** - All duct sections 24 (610mm) inches or wider, and over 48 (1219mm) inches in length, should be cross broken on top and bottom and should have standing seams or angle-iron braces. Joints should be S and drive strip, or locked.
- **Through Masonry Walls** - No warm air duct should come in contact with masonry walls. Insulate around all air duct through masonry walls with not less than 1/2" (1" is recommended) of insulation.
- **Through Unheated Space** - Insulate all exposed warm air ducts passing through an unheated space with at least 1/2" (1" is recommended) of insulation.
- **Duct Supports** - Suspend all ducts securely from adjacent buildings members. Do not support ducts from unit duct connections.
- **Duct Sizing** - Proper sizing of the supply air ductwork is necessary to ensure a satisfactory heating installation. The recognized authority for such information is the Air Conditioning Contractors Association, 2800 Shirlington Road, Suite 300, Arlington, VA 22206 (www.acca.org). A manual covering duct sizing in detail may be purchased directly from them.

CAUTION: An external duct system static pressure not within the limits shown on the rating plate, or improper motor pulley or belt adjustment, may overload the motor. See Hazard Levels, page 2.

- **Removable Panels** (See **FIGURE 42.**) - The ducts should have removable access panels. These openings must be accessible when the furnace is in service and should be a minimum of 6" x 10" (152mm x 254mm) in size so smoke or reflected light may be observed inside the casing to indicate the presence of leaks in the heat exchanger. Attach the covers for the openings in a manner that will prevent leakage.

FIGURE 42 - Connecting Supply Air Duct to the Furnace

- (1) Flanges on the furnace (heat exchanger) turn out as shown.
- (2) Shape duct connection as shown -- "U" on top and bottom; "L" on sides.
- (3) Slide "U" channels over furnace top and bottom flanges making connection.
- (4) Form "U" channels to seal sides. Drill and lock with sheetmetal screws.

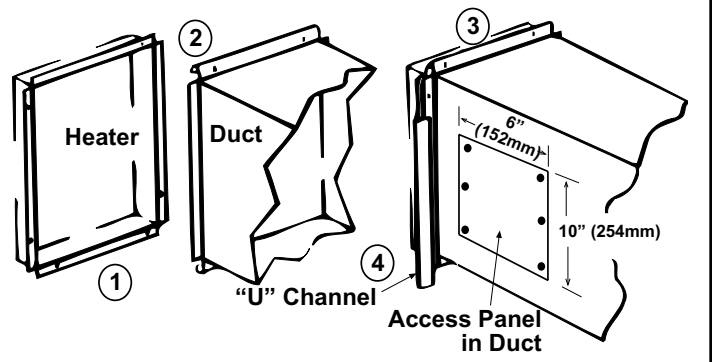
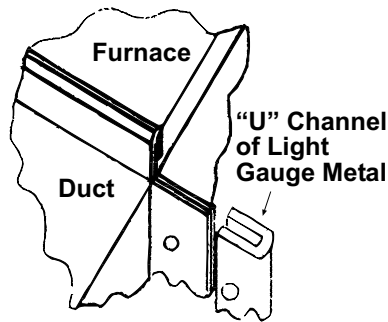
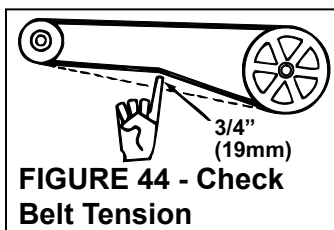

FIGURE 43 - Install "U" Channel on Sides of Duct Connection



- **Horizontal Discharge Duct Length** - A minimum horizontal duct run of 24" (610mm) is **recommended** before turns or branches are made in the duct system to reduce losses at the furnace outlet.
- **Supply Air Duct/Furnace Horizontal Connection** - The seal between the furnace and the duct must be mechanical. Duct connection should be made with "U" type flanges on the top and bottom of the connecting duct. Slide the duct over the flanges of the heater giving an airtight fit. Provide "U" type channels for the side flanges to ensure tight joints. Use sheetmetal screws to fasten ducts and "U" channels to the furnace flange. See **FIGURE 43.**

6.5 Blowers, Belts, and Drives



Check belt tension. Proper belt tension is important to the long life of the belt and motor. A loose belt will cause wear and slippage. Too much tension will cause excessive motor and blower bearing wear. Adjust the belt tension by turning the adjusting screw on the motor base until the belt can be depressed 3/4" (19mm). (See **FIGURE 44.**) After correct tension is achieved, re-tighten the locknut on the adjustment screw. Be sure that the belt is aligned in the pulleys.

Adjusting Blower Speed

The system is set at the factory for the RPM required to meet the CFM and external static pressure specified on the order. If estimated external static pressure is incorrect, or changes were made to the duct system, the blower RPM may have to be adjusted. Motors are equipped with adjustable pitch pulleys which permit adjustment of blower speed.

To make adjustments to units with less than a 5HP motor, follow these instructions.

1. Turn off the gas and the electric power.
2. Loosen belt tension and remove the belt.
3. Loosen the set screw on the side of the pulley away from the motor.
4. **To increase the blower speed, decreasing outlet temperature**, turn the adjustable half of the pulley inward. **To decrease the blower speed, increasing the outlet temperature**, turn the adjustable half of the pulley outward. One turn of the pulley will change the speed 8-10%.
5. Tighten the set screw on the flat portion of the pulley shaft.
6. Replace the belt and adjust the belt tension. Adjust tension by turning the adjusting screw on the motor base until the belt can be depressed 3/4". (See **FIGURE 44.**) Re-tighten the lock nut on the adjusting screw. Be sure that the belts are aligned in the pulley grooves properly and are not angled from pulley to pulley.

6.0 Mechanical (cont'd)

6.5 Blowers, Belts, and Drives (cont'd)

Adjusting Blower Speed (cont'd)

7. Turn on the electric and the gas. Light the heater following the instructions on the lighting instruction plate.
8. Check the motor amps with an amp meter. The maximum motor amp rating on the motor nameplate must not be exceeded.
9. When installation is complete, check for proper operation.

For units with a 5 HP and larger motor, follow these instructions for adjusting RPM:

1. Turn off the gas and the electric power.
2. Slack off all belt tension by moving motor towards driven shaft until belts are free of grooves. For easiest adjustment, remove the belts from the grooves.
3. On the outer locking ring, locate the two locking screws that are directly across from each other. Loosen these two screws, but do not remove them. Do not loosen any other screws.
4. Adjust sheave to desired pitch diameter by turning the outer locking ring. One complete turn of the outer locking ring will result in .233" change in pitch diameter. To **decrease** blower speed, **increase diameter**; to **increase** blower speed, **decrease diameter**.

CAUTION: Sheaves should not be adjusted in either direction to the point where movable and stationary flanges are in contact.

5. After completing adjustment, tighten both locking screws in the outer locking ring (loosened in Step 2.).
6. Replace belts and move motor away from the driven shaft to apply sufficient belt tension to prevent slippage. (See **FIGURE 44.**) Proper belt tension is important to the long life of the belt and motor. A loose belt will cause wear and slippage. Too much tension will cause excessive motor and blower bearing wear. Be sure that the belts are aligned in the pulley grooves and are not angled from pulley to pulley.
7. Check motor amps with an amp meter. The maximum motor amp rating on the nameplate must not be exceeded.
8. When installation is complete, check for proper operation.

Blower Pulley - Some blower pulleys require the use of a split taper bushing in the blower pulley. These split taper bushings must be loosened in order to remove the pulley. Follow these instructions to loosen the bushing:

- a) Notice that there are three cap screws in the bushing and two holes without screws, called push-off holes. (See **FIGURE 45.**)
- b) Remove the three cap screws.
- c) Put two of the cap screws into the two push-off holes. Tighten these two screws evenly until the pulley is loosened.
- d) Pulley may now be removed from the shaft.

Blower Bearings - The blower bearings on systems with less than a 10 HP motor (standard blower) are permanently lubricated cartridge ball bearings and do not require greasing.

The blower bearings on systems equipped with a 10-20 HP motor are pillow block ball bearings and are equipped with a grease fitting. These bearings should be lubricated twice a year with a high temperature, moisture-resistant grease (Type NLGI-1 or -2 standard grease is recommended). Be sure to clean the grease fitting before adding grease. Add grease with a handgun until a slight bead of grease forms at the seal. Be careful not to unseat the seal by over lubricating. **NOTE:** If unusual environmental conditions exist (temperatures below 32°F or above 200°F; moisture; or contaminants) or if unit is in continuous operation, more frequent service is required.

CAUTION: If the blower is unused for more than three months, bearings with a grease fitting should be purged with new grease prior to startup.

Blower Rotation - Each blower housing is marked for proper rotation. Rotation may be changed on single-phase motors by re-wiring in the motor terminal box. Three-phase motors may be reversed by interchanging two wires on the 3-phase supply connections.

FIGURE 45 - Split Taper Bushing

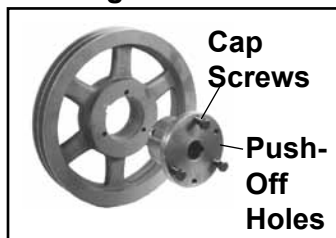

Optional Variable Frequency Drive

If the system is equipped with an optional variable frequency drive, the motor will operate on speeds as determined by the electrical frequency. 60 hertz is maximum speed. Speeds must be within the temperature rise range approved for a Model SCE Series 6 heater which is 30-90°F.

Follow the variable frequency controller manufacturer's instructions that are packaged with the heater (in the owner's envelope) to program the variable frequency drive settings. The formula for motor speed is $N = 120 \times f/p$ where N is speed; f is frequency; and p is number of poles (3600 RPM motor has 2 poles; an 1800 RPM motor has 4 poles).

Example: 1800 RPM motor on 60Hz; $N = 120 \times 60/4 = 1800$
 1800 is synchronous speed; assume 2% slip. Motor will run between 1750 and 1790 RPM at full load depending on design.
 Run the same motor at 45Hz ($120 \times 45/4 = 1350$). 1350 RPM less 2% slip equals about 1300 RPM.

Motor Loads and Amps

Use an amp meter to check blower motor amps. The following chart lists full load amps for various HP and voltages of open-type blower motors. Amps may be adjusted downward by reducing blower RPM or by increasing duct system static pressure. This chart can be used for sizing line wiring but should not be interpreted as the exact motor amps. See the motor rating plate for exact motor specifications. Do not exceed amp rating on the motor nameplate.

Venter motor amps for a 115 volt or 575 volt unit are 1.5 amps; venter motor amps for a 208, 230 or 460 volt unit are .8 amps.

Full Load Amps - Blower Motors (Open, Single Speed, Average)									
HP	1	1-1/2	2	3	5	7-1/2	10	15	20
208V/1	7.2	10.1	11.3	13.7	28.0				
230V/1	6.5	9.1	10.2	12.4	26.0	32.0	38.0		
208V/3	3.6	5.8	7.3	9.3	14.6	23.2	28.8	42.0	55.3
230V/3	3.2	5.2	6.6	8.4	13.2	21.0	26.0	38.0	50.0
460V/3	1.6	2.6	3.3	4.2	6.6	10.5	13.0	19.0	25.0
575V/3	1.3	2.1	2.6	3.4	5.3	8.4	10.4	15.2	20.0

7.0 Electrical Supply and Controls

7.2 Supply Voltage and Wiring

7.1 General

All electrical wiring and connections including electrical grounding must be made in accordance with local, state and national codes and regulations and with the National Electric Code ANSI/NFPA No. 70 (latest edition) or, in Canada, the Canadian Electrical Code, Part I-C.S.A. Standard C22.1. Check any local ordinances or gas company requirements that apply.

Check the rating plate on the heater for the supply voltage and the current requirements. A separate line voltage supply with fused disconnect switch should be run directly from the main electrical panel to the unit, making connection to the motor contactor or starter in the electrical box. All external wiring must be within approved conduit and have a minimum temperature rise rating of 60°C. Conduit from the disconnect switch must be run so as not to interfere with the service panels of the furnace.

Size of Field-Supplied Wire from Disconnect to Electrical Box for

Voltage/Phase	Motor HP	Wire Gauge	BX Cable
208/1 & 230/1	1 - 2	14	3/8"
	3	10	1/2"
	5	8	1/2"
	7.5	6	1"
	10	4	1"
208/3 & 230/3	1 - 3	14	3/8"
	5	12	3/8"
	7.5	10	1/2"
	10	8	1/2"
	15	6	1"
	20	4	1"

Voltage/Phase	Motor HP	Wire Gauge	BX Cable
460/3	1 - 7.5	14	3/8"
	10	12	3/8"
	15	10	1/2"
	20	8	1/2"
575/3	1 - 7.5	14	3/8"
	10 - 20	10	1/2"

Connection to Motor Contactor or Starter

Refer to the wiring diagram to identify any optional controls. If the system has an optional convenience outlet (Option BC), a separate power supply is required.

7.0 Electrical Supply and Controls (cont'd)

7.2 Supply Voltage and Wiring (cont'd)

7.3 Thermostat and Control Wiring

CAUTION: Make sure the thermostat has an adequate VA rating for the total requirements. Add coil rating of all relays and match thermostat rating. See Hazard Levels, page 2.

Disconnect Switch

A disconnect switch is a required part of this installation. The disconnect switch may be fusible or non-fusible. When providing or replacing fuses in a fusible disconnect switch, use dual element time delay fuses and size according to 1.25 times the maximum total input amps. A disconnect switch is available as optional equipment or may be supplied locally. When installing the disconnect switch, be careful that the conduit and switch housing are clear of all service panels. Allow at least four feet (1.2M) of service room between the disconnect switch and any removable service panels.

WARNING

If you turn off the power supply, turn off the gas. See Hazard Levels, page 2.

CAUTION: If any of the original wire as supplied with the appliance must be replaced, it must be replaced with wiring material having a temperature rating of at least 105°C, except for sensor lead wires which must be 150°C. See Hazard Levels, page 2.

The heater is equipped with a low voltage (24V) control circuit. See the wiring diagram in the heater electrical box.

A thermostat is not supplied with the furnace. Use either an optional or a field-provided low-voltage (24V) thermostat. Install the thermostat according to the manufacturer's instructions.

If the low-voltage thermostat is equipped with a heat anticipator, set the anticipator at full load control amps. See chart below for amp ratings of optional controls.

Approximate Ampere Rating of 24-Volt Controls

Fan Control Time Delay12 amps
Spark Ignition System1 amps
Maxitrol Gas Control System51 amps
Heater14 amps
RBM Relay Coil	2 amps
Single-Stage Gas Valve6 amps
Contactor Coil45 amps
Two-Stage Gas Valve6 amps

Separately activated relays must be substituted at the unit thermostat connections to cycle more than one furnace from one thermostat.

There are a variety of optional controls available as part of the gas and air control options. Check the wiring diagram and literature supplied with the unit for operation of factory-installed optional controls. See **FIGURE 46** for location of electrical connections (Codes 18 and 39) and standard and optional controls.

Optional shipped-separate heating and makeup air controls could include a single or two-stage thermostat, system switches, selectostat, freezestat, an automatic night setback device, a Maxitrol temperature selector, potentiometer, a pressure null switch, or a combination of these controls. Each of these should be installed according to the manufacturer's instructions packaged with the heater.

Remote Console

A selection of consoles is available with specific combinations of controls factory mounted. Consoles include indicator lights for the blower and burner, an off/on system switch, terminal block wiring, and may include optional controls. Consoles are shipped separately for remote installation and can be either mounted on a wall or recessed.

Field Control Wiring - Length and Gauge	Total Wire Length	Distance from Unit to Control	Minimum Recommended Wire Gauge
	150'	75'	#18 gauge
	250'	125'	#16 gauge
	350'	175'	#14 gauge

8.0 Controls

8.1 Control Locations

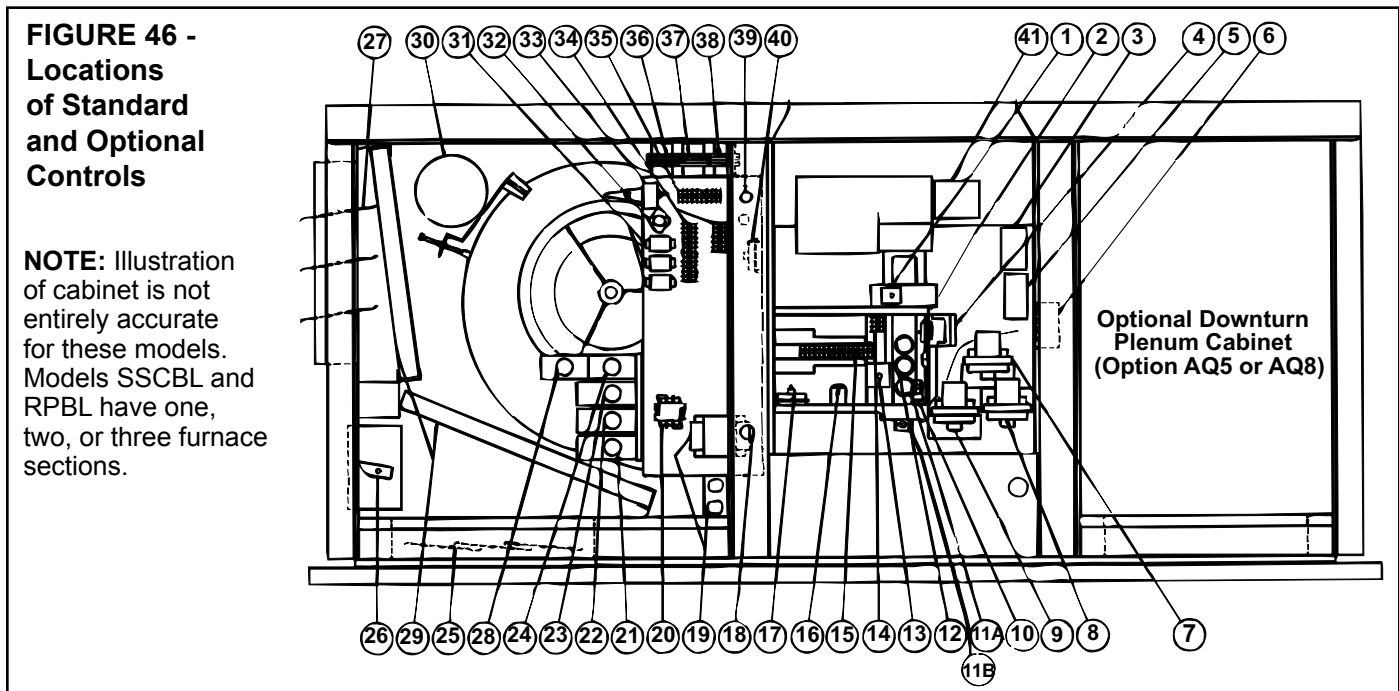

1) Optional Auto Reset Freezestat	10) Time Delay Relay (power-vented)	20) Blower Motor Contactor or Starter	31) Optional Control Relays (as required, 8 maximum)
2) Combustion Air Pressure Switch	11A) Limit Control (disc type limit control)	21) Optional High Ambient Limit Control and/or Optional AG41 or 42 Heat Stage Controls (2 or 4)	32) Auto Reset Reverse Flow Limit
3) Optional Discharge Air Firestat	11B) Limit Control (capillary type limit control)	22) Optional Outside Air or Return Air Controller	33) Optional Return Air Firestat
4) Ignition Controller	12) Fan Control	23) Optional Mixed Air Controller	34) Low Voltage Terminal Strip
5) Optional Maxitrol Discharge Air Sensor (Opt AG8 or AG9)	13) Optional Freezestat Time Delay Relay	24) Optional Potentiometer	35) Line Voltage Terminal Strip
6) Optional Two-Stage Controller (Opt AG3) or Maxitrol Amplifier (Opt AG7, AG8 or AG9)	14) Line Voltage Terminal Block	25) Optional Return Air Dampers	36) Control Transformer
7) Optional Main Low Gas Pressure Switch	15) Low Voltage Terminal Block	26) Optional Two Position or Modulating Damper Motor	37) Control Transformer (as required)
8) Optional Pilot High Gas Pressure Switch	16) Freezestat Relay	27) Optional Outside Air Damper	38) Optional Damper Motor Transformer
9) Optional Main High Gas Pressure Switch	17) Optional Dirty Filter Pressure Switch	28) Optional Potentiometer	39) Low Voltage Connection (field)
	18) Line Voltage Connection (field)	29) Optional Filters	40) Optional Air Proving Switch
	19) Opt Convenience Outlet and Outlet Transformer	30) Blower Motor	41) Venter Assembly

8.2 Fan Control

1. A fan control provides for the following control of the blower.
 - (a) After the gas valve opens, there is a time delay of blower operation to prevent the discharge of cold air.
 - (b) Blower operation continues after the thermostat is satisfied as determined by the fan time delay.
2. To be sure that the blower can continue to operate, the power supply to the furnace **MUST NOT** be interrupted **except** when servicing the unit.
3. If the customer wants the furnace off at night, the gas valve circuit **SHOULD BE OPENED** by a single pole switch wired in series with the thermostat. Some thermostats are provided with this feature. Multiple units controlled from a single thermostat are shut off in the same manner. For proper operation, be sure the fan control wiring is observed

Refer to the wiring diagram furnished with the furnace. For location, See **FIGURE 46** Item 12.

Service NOTE: To replace a fan control on units manufactured prior to 11/04, a replacement kit is required. Order **P/N 209184**.

8.0 Controls (cont'd)

8.4 Optional Airflow Proving Switch (Makeup Air Only)

8.5 Reverse Flow, Limit Control

8.6 Optional High Ambient Limit Control

8.7 Combustion Air Proving Switch

8.8 Gas Controls

8.3 High Temperature Limits

Each furnace is equipped with a non-adjustable high temperature limit switch which shuts off the gas in the event of motor failure, lack of air due to dirty filters, or restrictions at the inlet or outlet of the unit. See Paragraph 9.3, "Check Installation after Start-up", for checking operation of high temperature limit controls.

The furnace farthest downstream in each system is also equipped with a linear-type limit control. The switch is mounted on a bracket on the bottom of the junction box with the capillary sensor extending across the discharge opening of the furnace.

See **FIGURE 46**, Items 11A and 11B.

The optional airflow switch ensures that the circulating air blower is functionally providing an adequate amount of airflow prior to the unit being fired. The switch is a single pole - normally open - device which closes when an increase in pressure above the setpoint, is sensed in the circulating air blower. The switch is located in the blower junction box (See **FIGURE 46**, Item 40).

Air Proving Switch (Option BW1)

Contacts will close at .26" w.c. maximum

The furnace is factory equipped with an automatic reset reverse flow limit control. This control is located in the blower compartment, mounted in the blower junction box adjacent to the blower inlet opening, and is wired in series with the main limit control mounted on the heat exchanger duct side. For location, See **FIGURE 46**, Item 32.

In case of belt breakage or motor failure, the limit control will be opened by the high temperatures caused by reverse flow from the heat exchanger to the blower compartment, thus breaking the circuit to the electric gas valve and preventing burner operation.

The optional high ambient limit control functions to shut off the burner when the entering outside air reaches a set temperature. The temperature setting is field adjustable from 0-100°F. (For location, see **FIGURE 46**, Item 21.)

The combustion air proving switch ensures that proper combustion air flow is available. The switch is a single-pole, double-throw switch, which senses pressure caused by the flow of combustion air from the venter. The switch is designed to close when a decreasing pressure is sensed in the outlet duct of the flue collection box.

On start-up when the furnace is cold, the sensing pressure is at the most negative level, and as the furnace and the flue system warm-up, the sensing pressure becomes less negative. After the system has reached equilibrium (approximately 20 minutes), the sensing pressure levels off. If a restriction or excessive flue length or turns cause the sensing pressure to become less than the switch setpoint, the pressure switch will function to shut off the main burners. The main burners will remain off until the system has cooled and/or the flue system resistance is reduced. The table below gives approximate water column negative pressure readings and switch setpoints for sea level operating conditions.

Startup Cold Equilibrium Factory Setpoint

-1.0" w.c. -.70" w.c. -.63 +- .05" w.c.

DANGER

Safe operation requires proper venting flow. Never bypass the combustion air proving switch or attempt to operate the unit without the venter running and proper flow in the vent system. Hazardous condition could result. See Hazard Levels, page 2

8.8.1. Operating Valve

WARNING

The operating valve is the prime safety shutoff. All gas supply lines must be free of dirt or scale before connecting the unit. See Hazard Levels, page 2.

All furnaces are standardly equipped with a 24-volt combination valve which includes the automatic electric on-off valve controlled by the room thermostat, the pressure regulator, the safety pilot valve, and the manual shutoff valve. The standard gas valve allows for single-stage control from a single-stage, 24-volt thermostat.

8.8.2 Optional Two-Stage Operation - Heating Only

The standard combination control valve is replaced with a two-stage combination gas control valve providing for low fire or high fire operation controlled by a two-stage thermostat. First stage (low fire) is factory set (not field adjustable). Both high and low stages are controlled by a Servo regulator, maintaining constant gas input under wide variations in gas supply pressure. See instructions packed with the unit for specific gas valve specifications, wiring, and operating instructions.

8.8.3 Optional Two-Stage Operation - Makeup Air

On systems with more than one furnace section, there are two methods of achieving multiple-stage makeup air operation. In addition, for each of these methods, there are two types of control mechanisms. Consult the wiring diagram on the furnace to identify the optional control system (Option AG 3, 15, 4, 5, 17, 18, 19, or 20).

The first method, identified by **Options AG3 or AG15**, is comparable to the two-stage heating units. Instead of control from a two-stage room thermostat, the discharge air temperature is monitored and the two-stage gas valve is controlled by a two-stage ductstat. When the discharge air temperature drops to the setpoint, low fire is energized. If low fire cannot satisfy the ductstat setting, high fire is energized. Since the packaged systems may include two or three furnace sections, and each section is equipped with a two-stage gas valve, the operation stages increase with the number of furnace sections. Set the ductstats as indicated in **TABLE A, below**.

The second method of multiple-stage makeup air operation is applicable only to systems that include two or three furnace sections. On systems with two furnaces, this optional control system is identified as **Option AG4, AG17, or AG18**. On packaged systems with three furnace sections, this optional control method is identified as **Option AG5, AG19, or AG20**. Each furnace in the package is equipped with a single-stage gas valve. The single-stage gas valves are staged by two-stage ductstats. The furnaces are staged in sequence. This concept will achieve two-stage control on packaged systems with two furnaces and three-stage control on systems with three furnaces. Set the ductstats as indicated in **TABLE B, page 46**.

The two types of ductstat control mechanisms used in these multiple-stage systems are **either --**

- (1) the complete ductstat (including the sensor and temperature selector; see **FIGURE 47**) is installed in the furnace discharge (Option AG3, AG4, and AG5) **or**
- (2) a sensing probe only is installed in the heater discharge (See **FIGURE 49**.) with the sensing probe electrically connected to a remote electronic temperature selector (**FIGURE 48**).

TABLE A - Recommended Settings for Staging Application - Options AG3, AG15

Option	No. of Furnaces	Ductstat Settings - Set <i>each</i> ductstat control (See FIGURE 47) in furnace "order"				Sequence of Staging with these settings				
		1st	2nd	3rd	4th					
AG3	1	70°F	--	--	--	66°F High Stage ► 70°F Low Stage ► 74°F Shutdown				
	2	70°F	64°F	--	--	60°F High Stage Both Furnaces ► 64°F Low Stage 2nd Furnace ► 68°F Shutdown 2nd furnace ► 70°F Low Stage 1st furnace ► 74°F Shutdown 1st furnace				
	3	70°F	66°F	62°F	--	58°F High Stage All Furnaces ► 62°F Low Stage 3rd Furnace ► 66°F Shutdown 3rd Furnace; Low Stage 2nd Furnace ► 70°F Shutdown 2nd furnace; Low Stage 1st Furnace ► 74°F Shutdown 1st Furnace				
Option AG15 - Adjust the setpoint and the differential of the temperature selector (Johnson #A350). Adjust the offset potentiometer on each of the stage adder modules (Johnson #S350). The settings listed below will provide the same sequence of staging as shown above for Option AG3. Follow the manufacturer's instructions provided. IMPORTANT: Set the temperature selector and each stage adder module to "HEAT". Follow the wiring diagram to obtain proper sequencing.										
Option	No. of Furnaces	Temperature Selector (A350)		Stage Adder (S350) Offset Settings (Refer to FIGURE 48)						
		Setpoint	Differential							
AG15	1	74°F	8°F	4°F	--	--	--	--	--	--
	2	74°F	14°F	10°F	6°F	4°F	--	--	--	--
	3	74°F	16°F	10°F	8°F	8°F	4°F	4°F	--	--
Operation: The differential setting and offset degrees allow the controls to adapt to any adjustment in temperature selection (50-130°F).										

8.0 Controls (cont'd)

8.8 Gas Controls (cont'd)

8.8.3 Optional Two-Stage Operation - Makeup Air (cont'd)

TABLE B - Recommended Settings for Staging Application - Options AG4, AG5, AG17, and AG19						
Option	No. of Furnaces	Ductstat Settings - Set <i>each</i> Ductstat (See FIGURE 47) in furnace "order"				Sequence of Staging with this setting
		1st	2nd	3rd		
AG4	2	70°F	--	--		66°F Full Rate Both Furnaces ► 70°F Shutdown 1st Furnace ► 74°F Shutdown 2nd furnace
AG5	3	70°F	64°F	--		60°F Full Rate Both Furnaces ► 68°F Shutdown 2nd & 3rd Furnace ► 74°F Shutdown 1st furnace
Options AG17, AG18, AG19, AG20 - Adjust the setpoint and the differential of the temperature selector (Johnson #A350). Adjust the offset potentiometer on each of the stage adder modules (Johnson #S350). The settings listed below will provide the same sequence of staging as shown above for Option AG4. Follow the manufacturer's instructions provided. IMPORTANT: Set the temperature selector and each stage adder module to "HEAT". Follow the wiring diagram to obtain proper sequencing.						
Option	No. of Furnaces	Temperature Selector (A350)		Stage Adder (S350) Offset Settings (Refer to illustrations in FIGURE 48)		
		Setpoint	Differential			
AG17	2	74°F	8°F	4°F	--	--
AG19	3	74°F	10°F	6°F	6°F	--
Operation: The differential setting and offset degrees allow the controls to adapt to any adjustment in temperature selection (50-130°F).						

The makeup air control options with the complete two-stage ductstat (Options AG3, AG4, AG5) installed in the heater discharge use a ductstat (See FIGURE 47) with an adjustable range from 0° to 100°F with a fixed differential of 2-1/2°. Due to different CFM settings and outside air temperatures, the average downstream outlet temperature may not match the ductstat setting exactly. After the installation is complete, re-adjust the setpoint of the ductstat(s) to achieve the desired average discharge air temperature. In general, makeup air applications are usually adjusted to discharge an outlet air temperature between 65°F and 75°F.

Two-stage makeup air options that are controlled from a sensing probe with a remote electronic temperature selector have a temperature operating range to 130°F. The sensing probe and remote modules (FIGURE 48) are shipped separately for field installation. Follow the wiring diagram with the unit and the manufacturer's instructions for wiring and installing the remote modules. **CAUTION: Make sure heat/cool selector switch is set on "HEAT"**. Depending on the staging provided, there will be one module for selecting temperature and one to five stage-adder modules. The digital display module is optional.

See TABLE A, page 45, or TABLE B, above, for recommended settings and staging sequence of all two-stage options.

FIGURE 47 - Ductstat Control in Option AG3, AG4, and AG5

Factory set as listed in TABLES A and B.

Adjustable range 0-100°F; markings are on the dial.



FIGURE 48 - Remote Temperature Selector (A); and Stage-Adder Module (B)

for Ductstat in Makeup Air Control Options (Options AG 15, 17, and 19)



FIGURE 49 - Duct Temperature Sensor Location

1. Remove access panel in the ductwork adjacent to the control compartment access panel.
2. Element is retained by either spring clips or cable straps.
3. Round gasket and metal retaining plate provide airtight seal for capillary and must be removed to remove the element.

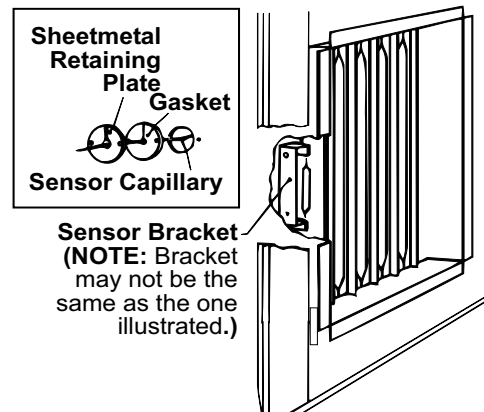

8.8.4 Optional Electronic Modulation

Installation Note: Sizes 400, 700, 800, 1050, and 1200 with electronic modulation gas controls require a minimum of 6" w.c. natural gas supply pressure.

The type and capability of the electronic modulation system depends on the option selected. Electronic modulation options are identified by a suffix to the Serial No. printed on the heater rating plate. AG7 is identified as MV-1; AG8 is identified as MV-3; AG9 is identified as MV-4; AG21 is identified as MV-A; AG39 is identified as MP-1; and AG40 is identified as MP-2. AG39 and AG40 are available only on Size 400. AG41 is identified as MP3 and AG42 is identified as MP4. Both AG41 and AG42 apply only to Sizes 500, 600, 800, and 1200.

Electronic Modulation between 50% & 100% Firing Rate (Options AG7, AG8, AG9)

Depending on the heat requirements as established by the thermistor sensor, the burner modulates between 100% and 50% firing. The thermistor is a resistor that is temperature sensitive in that as the surrounding temperature changes, the Ohms resistance changes through the thermistor. This change is monitored by the solid state control center (amplifier) which furnishes varying DC current to the modulating valve to adjust the gas input.

Each modulating valve is basically a regulator with electrical means of raising and lowering the discharge pressure. When no DC current is fed to this device, it functions as a gas pressure regulator, supplying 3.5" w.c. pressure to the main operating valve. Refer to the wiring diagram supplied with the furnace for proper wiring connections. Electronic modulation for heating controlled by a specially designed room thermostat (60°-85°F) is identified as Option AG7. Electronic modulation control systems for makeup air applications controlled by a duct sensor and temperature selector (55-90°F) are identified as either Option AG8 or Option AG9. The temperature selector setting for Option AG8 is on the amplifier; Option AG9 has a remote temperature selector. Both systems are available with an override thermostat.

Computer Controlled Electronic Modulation between 50% and 100% Firing Rate (Option AG21)

With this option the furnace is equipped with a Maxitrol signal conditioner which operates much the same way as the amplifier above to control the regulator valve. The conditioner accepts an input signal of either 4-20 milliamps or 0-10 volts from a customer-supplied control device such as a computer. With the dip switches on the conditioner in the "on" positions, the conditioner accepts a 4-20 milliamp signal. In the "off" positions, the conditioner accepts a 0-10V signal. The conditioner converts the signal to the 0 to 20 volt DC current required to control the modulating valve. Temperature selection is through the computer software.

FIGURE 50 - Maxitrol conditioner in Options AG21, AG40, and AG42



Electronic Modulation between 25% and 100% Firing Rate), Options AG39, AG40, AG41, AG42 - Available only with natural gas

A Size 400 unit equipped with electronic modulation Option AG39 has a 25%-100% firing range (4:1 turndown ratio). Option AG41 applies to Sizes 500, 600, and 800 with two furnaces and Size 1200 with three furnaces. The furnace closest to the blower is equipped with the electronic modulation option. The other furnace(s) have two-stage burner control from outside air temperature sensors identified as heat stage controllers. Option AG41 provides 6:1 turndown with two furnaces and 8:1 turndown with three furnaces.

8.0 Controls (cont'd)

8.8 Gas Controls (cont'd)

8.8.4 Optional Electronic Modulation (cont'd)

Electronic Modulation between 25% and 100% Firing Rate), Options AG39, AG40, AG41, AG42 (cont'd)

The furnace with this type of electronic modulation will ignite at any input rate in the available range and will maintain average thermal efficiencies equal to or greater than the thermal efficiency at full fire. The following table applies to the furnace with the manifold illustrated in **FIGURE 51**.

Size	Maximum Turndown	MBH Input Range	Inlet Pressure to Modulating Valve (factory set)	Gas Supply Pressure Required
400	25%	100-400	4.4" w.c.	6" w.c.
500	28%	69-250	4.0" w.c.	5" w.c.
600	23%	69-300	4.0" w.c.	5" w.c.
800	25%	100-400	4.4" w.c.	6" w.c.
1200	25%	100-400	4.4" w.c.	6" w.c.

FIGURE 51 - Manifold Arrangement on Furnace with Optional Electronic Modulation between 25-100% Firing Rate

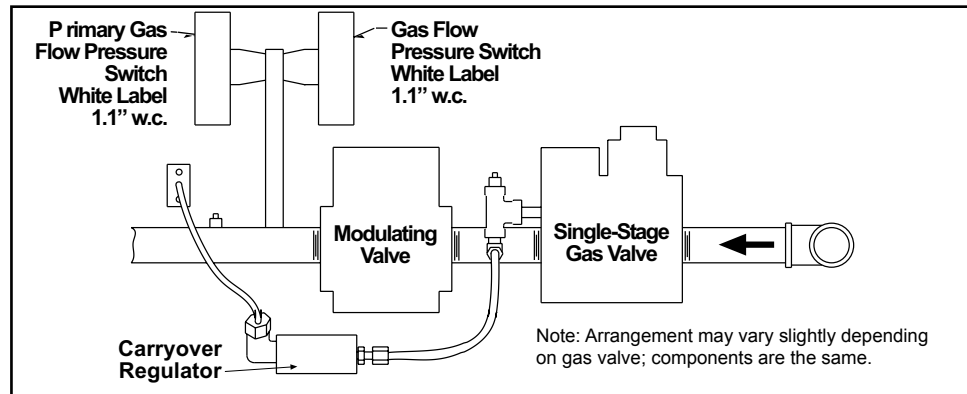

The gas train (**FIGURE 51**) in a furnace with this type of electronic modulation control includes a single-stage gas valve, a modulating valve, and two gas pressure switches. The burner rack is equipped with one flash carryover and a regulated gas lighter tube system. The carryover lighter tube receives its gas supply through the regulator, simultaneously with the gas to the burner. Control of the system is through a Maxitrol amplifier with a corresponding remote temperature dial.

Description of Operation - furnace with Option AG39, AG40, AG41 or AG42

The gas supply (6" w.c. required) connects to the single-stage gas valve. To compensate for additional pressure loss through the modulating valve, the single-stage gas valve has a custom outlet pressure setting higher than when it is used on a standard gas manifold. The pilot tubing connects to the pilot port on the single-stage gas valve. When the valve receives a call for heat from the amplifier and pilot is established, gas flow from the single-stage valve goes to both the modulating valve and the regulated lighter tube system. **When the signal from the amplifier to the modulating valve requires less-than-high fire operation**, the modulating valve functions to lessen the gas flow to the burner to reduce the input rate to that required to maintain the desired temperature. When the input rate is reduced enough to decrease the gas pressure to 1.1" w.c., the primary gas pressure switch in the manifold activates the gear motor that controls the bypass damper in the venter/combustion air system. The bypass damper opens diverting some of the incoming air directly into the flue duct, reducing airflow through the burner. Safety switches monitor the position of the bypass damper. When the gas pressure increases above 1.1" w.c., the bypass damper closes.

Combustion Air Pressure Switch Setting

This uniquely designed modulation system requires combustion air pressure settings different from the standard system. The approximate settings for the combustion air proving switch at sea-level operation are shown in the table.

w/AG 39, 40, 41, 42	Startup Cold	Equilibrium at Full Rate	Factory Setting
400	-1.2"w.c.±0.2	-0.95"w.c.±0.1	-.75"w.c.±0.5
500	-1.2"w.c.±0.2	-0.95"w.c.±0.1	-.75"w.c.±0.5
600	-1.2"w.c.±0.2	-0.95"w.c.±0.1	-.75"w.c.±0.5
800	-1.2"w.c.±0.2	-0.95"w.c.±0.1	-.75"w.c.±0.5
1200	-1.2"w.c.±0.2	-0.95"w.c.±0.1	-.75"w.c.±0.5

Sensor Location - Options AG39 and AG41

For the convenience of the installer, the duct temperature sensor is factory installed in the cabinet leg (See **FIGURE 49, page 47**). Although the sensor has a mixing tube, at this distance from the discharge it does not receive a true mix, so the temperature read by the sensor will be slightly higher than the actual air entering the ductwork. The system will provide comfort level heat if the selector is set slightly lower to compensate for this reading. The offset temperature will vary with the application. If a direct correlation of these two temperatures is required, move the duct sensor to a location in the ductwork about 10-12 feet (3 - 3.7M) from the furnace discharge.

Set Heat Stage Controllers - applies to Options AG41 and AG42 only

Systems with Option AG41 and AG42 have "heat stage controllers" that control operation of the "two-stage" furnace based on outside air temperature setpoints. Proper setpoints are important to ensure the modulating furnace ("Heat Stage 1") is always in control and avoids cycling. The proper setpoint for each controller must be determined from basic design information. Sizes 500, 600, and 800 with two furnace sections have two heat stage controllers; Size 1200 with three furnace sections has four heat stage controllers.

Follow the steps and example to determine appropriate setpoints. Follow the instructions to locate and set the controllers.

Calculate the Setpoints with Two Furnace Sections

- Use the following formulas to calculate the controller settings for Heat Stage 2 and Heat Stage 3 in a system with two furnace sections.

T_{SP} = Setpoints of Heat Stage Controllers (T_{SP2} and T_{SP3})
 T_{SA} = Desired Supply Air Temperature
 T_D = Design (minimum) Entering Air Temperature

Formulas for two furnace sections:

Setpoint for Heat Stage 2: $T_{SP2} = T_{SA} - 0.46 (T_{SA} - T_D)$

Setpoint for Heat Stage 3: $T_{SP3} = T_{SA} - 0.73 (T_{SA} - T_D)$

EXAMPLE : 3600 CFM, Power vented, 100% Outside Air, -10°F Outdoor Winter Design, 75°F Desired Supply Air

$$T_{SP2} = 75 - [.46 \times (75 - (-10))] = 75 - (.46 \times 85) = 35.9$$

$$T_{SP3} = 75 - [.73 \times (75 - (-10))] = 75 - (.73 \times 85) = 12.9$$

Set Stage Heat #2 Controller to 36°F

Set Stage Heat #3 Controller to 13°F

Calculate the Setpoints with Three Furnace Sections

- Use the following formulas to calculate the controller settings for Heat Stage 2, Heat Stage 3, Heat Stage 4, and Heat Stage 5 in a system with three furnace sections.

T_{SP} = Setpoints of Heat Stage Controllers (T_{SP2} , T_{SP3} , T_{SP4} , T_{SP5})
 T_{SA} = Desired Supply Air Temperature
 T_D = Design (minimum) Entering Air Temperature

Formulas for three furnace sections:

Setpoint for Heat Stage 2: $T_{SP2} = T_{SA} - 0.30 (T_{SA} - T_D)$

Setpoint for Heat Stage 3: $T_{SP3} = T_{SA} - 0.49 (T_{SA} - T_D)$

Setpoint for Heat Stage 4: $T_{SP4} = T_{SA} - 0.65 (T_{SA} - T_D)$

Setpoint for Heat Stage 5: $T_{SP5} = T_{SA} - 0.82 (T_{SA} - T_D)$

EXAMPLE : 8850 CFM, Power vented, 100% Outside Air, -10°F Outdoor Winter Design, 75°F Desired Supply Air

$$T_{SP2} = 75 - [.30 \times (75 - (-10))] = 75 - (.30 \times 85) = 49.5$$

$$T_{SP3} = 75 - [.49 \times (75 - (-10))] = 75 - (.49 \times 85) = 33.3$$

$$T_{SP4} = 75 - [.65 \times (75 - (-10))] = 75 - (.65 \times 85) = 19.8$$

$$T_{SP5} = 75 - [.82 \times (75 - (-10))] = 75 - (.82 \times 85) = 5.3$$

Set Stage Heat #2 Controller to 49°F

Set Stage Heat #3 Controller to 33°F

Set Stage Heat #4 Controller to 20°F

Set Stage Heat #5 Controller to 5°F

Locate and Set the Heat Stage Controllers

- In the inlet air section, locate the heat stage controllers. The same type of controller may also be used as the optional high ambient limit control (Option BN2) and as the mixed air controller that is part of certain air control options (Options AR12, AR13, AR15, and AR16). Identify the controllers marked Heat #2 and Heat #3 or Heat #2, Heat #3, Heat #4, and Heat #5.

2 Furnaces - Identify controllers marked Heat #2 and Heat #3; set as calculated above.

3 Furnaces - Identify controllers marked Heat #2, Heat #3, Heat #4, and Heat #5; set as calculated above.

- Adjust each controller to the setpoint as determined in the calculation.

8.0 Controls (cont'd)

8.8 Gas Controls (cont'd)

8.8.4 Optional Electronic Modulation (cont'd)

Electronic Modulation between 25% and 100% Firing Rate), Options AG39, AG40, AG41, AG42 (cont'd)

Wiring and Service

For wiring, consult the wiring diagram attached to the furnace. All wires in the electrical box connecting the modulation controls must be 150°C.

This is a unique system which includes custom-built components and custom settings. If service is required, follow the general troubleshooting guide and the special troubleshooting guide in **FIGURE 52**.

FIGURE 52 - Troubleshooting Guide for Checking Bypass Combustion Air Damper Safety Circuit on units with Option AG39, AG40, AG41, or AG42

Symptom - Part 1:

Main burners are inoperative.

Assumes that 24 volts is available between Terminal 2 and Terminal 7.

General Instructions:

For each step, check to ensure that the wiring is not defective and that the wiring connections are secure.

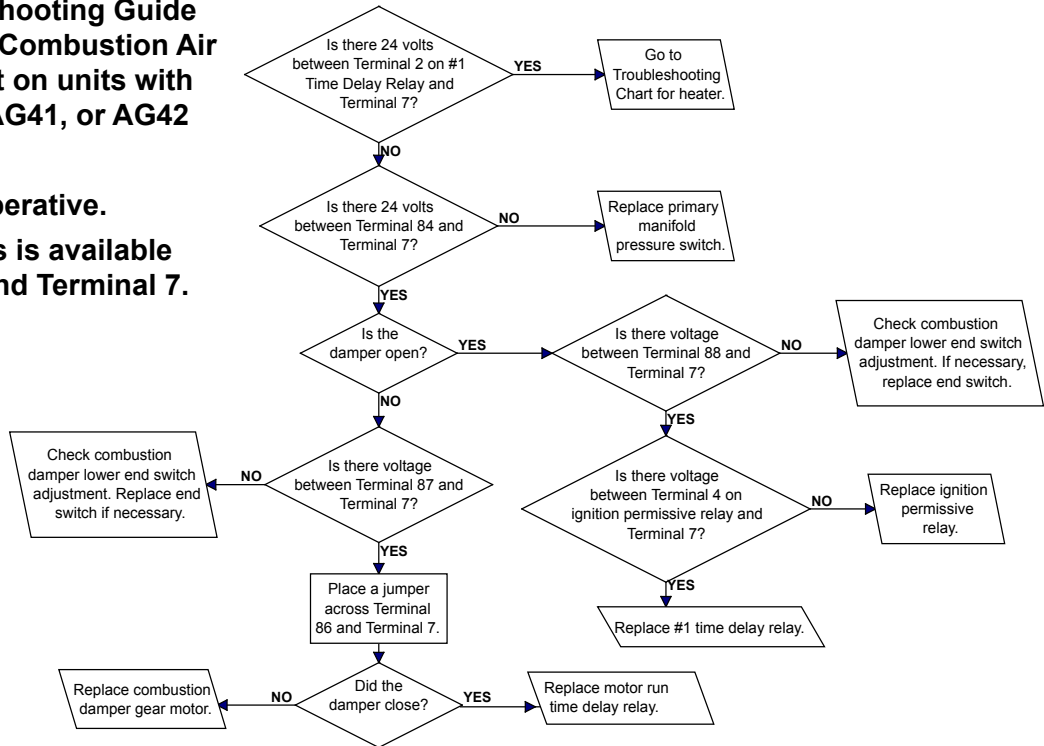

Symptom - Part 2:

Steady call for heat - burner cycles. Assumes that 24 volts is available between Terminals 11 and 7 and Terminals 2 and 7.

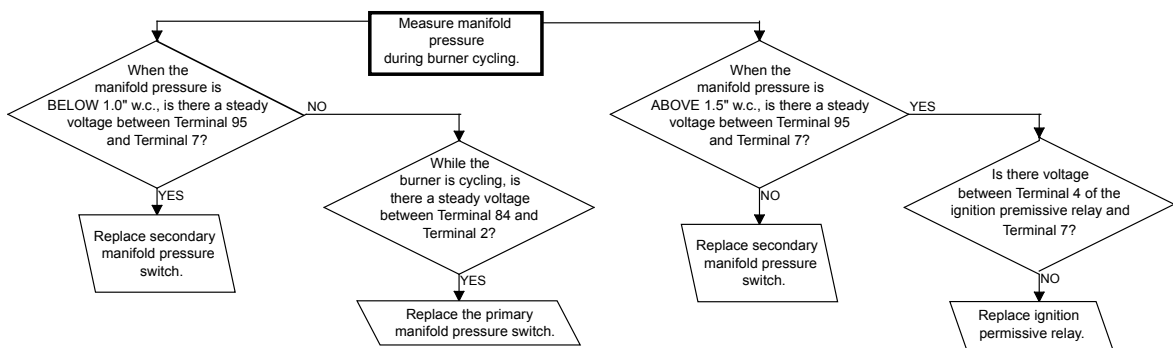

Computer Controlled Electronic Modulation between 25% and 100% Firing Rate, Option AG40 and AG42

The furnace functions and is equipped in the same way as for Options AG39 and AG41 except that the temperature settings are selected through field-supplied computer software and there is no temperature selector or duct sensor.

The furnace is equipped with a Maxitrol signal conditioner (see **FIGURE 50**) which accepts an input signal of either 4-20 milliamps or 0-10 volts from a customer-supplied control device such as a computer. With the dip switches on the conditioner in the "on" positions, the conditioner accepts a 4-20 milliamp signal. In the "off" positions, the conditioner accepts a 0-10V signal. The conditioner converts the signal to the 0 to 20 volt DC current required to control the modulating valve.

8.9 Pilot and Ignition Systems

Service NOTE: If replacing an earlier model of ignition controller, order replacement kit **P/N 257472** for a unit with recycling gas control Option AH2 or **P/N 257473** for Option AH3 gas control with lockout. (Option codes are listed on the unit wiring diagram.)

FIGURE 53 - Ignition Controllers

Ignition System - Natural gas units are equipped with a spark ignited intermittent safety pilot system that shuts off the pilot gas flow between heat cycles. Propane units (or as an option on natural gas units) require a lockout device that stops the gas flow to the pilot if the pilot fails to light in 120 seconds. The lockout device has a 1-hour retry or requires manual reset by interruption of the thermostat circuit. Refer to the wiring diagram supplied with the unit for pilot system identification and proper wiring. Pilot with lockout is Option AH3; non-lockout spark pilot is Option AH2.

Ignition Controller - As part of the intermittent safety pilot systems, the ignition controller provides the high voltage spark to ignite the pilot gas and also acts as the flame safety device. After ignition of the pilot gas, the ignition controller electronically senses the pilot flame. A low voltage DC electrical signal is imposed on the separate metal probe in the pilot assembly. The metal probe is electrically insulated from ground. The pilot flame acts as a conduction path to ground completing the DC circuit and proving pilot flame. With pilot flame proven, the ignition controller energizes the main gas valve.

CAUTION: Due to high voltage on pilot spark wire and pilot electrode, do not touch when energized. See Hazard Levels, page 2.



Pilot - All pilots are vertical, target type with lint-free feature. Pilot flame should be approximately 1-1/4" in length. Pilot gas pressure should be the same as the supply line pressure. Pilot gas is supplied through the combination valve; the pilot gas flow is controlled by an adjustment screw located in the valve body. For maintenance, see Paragraph 10.2.2.

8.10 Burners, Orifices, and Carryover System

Burners - Individually formed steel burners capable of operating on either natural or propane gas are used in this heater. These burners have accurate, machine-formed ports to give controlled flame stability and operation without lifting or flashback. All burners are lightweight and factory mounted in an assembly which permits all of the burners to be removed as a unit for inspection or service.

Burner Carryover Systems (FIGURES 54 and 55) - All **natural gas** burners (except when equipped with electronic modulation Option AG39, AG40, AG41 or AG42; see Paragraph 8.8.4) are equipped with two flash carryover systems, one on each end of the burner rack. (**NOTE:** A natural gas burner rack on furnaces manufactured prior to Series 6 had a gas lighter tube carryover and one flash carryover.)

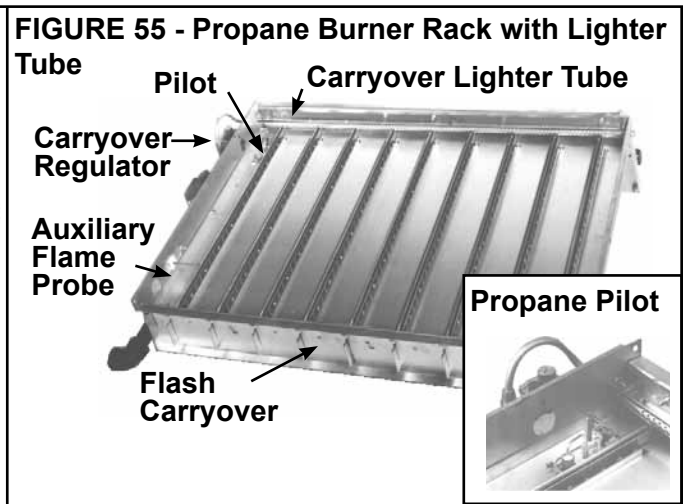
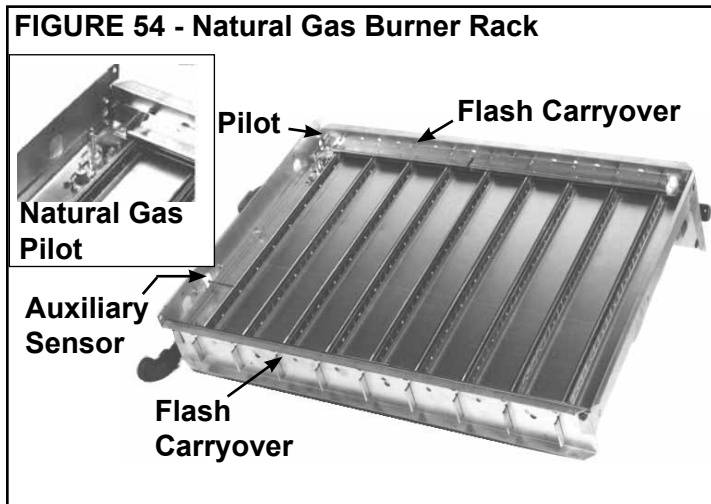

8.0 Controls (cont'd)

8.10 Burners, Orifices, and Carryover System (cont'd)

All **propane gas** burners are equipped with one flash carryover and a regulated gas lighter tube system. The carryover lighter tube receives its gas supply through a regulator, simultaneously with the gas to the burner orifices.

During regular service, check the main burner ports, the carryover assemblies, and the orifices for cleanliness.

Burner Orifices - Heaters are shipped with orifices of proper size and type for gas specified. **NOTE:** Natural gas units do not require a carryover orifice.

Size	Burner Orifices (sea level)					Propane Carryover Orifice	
	Qty per Furnace	Natural Gas		Propane		Drill Size	P/N
		Drill Size	P/N	Drill Size	P/N		
500	12	#44	11833	#55	11830	#59	10370
600	12	#42	84437	1.45 mm	61652	#59	10370
700, 1050	14	#42	84437	1.45 mm	61652	#56	9791
400, 800, 1200	16	#42	84437	1.45 mm	61652	#56	9791

8.11 Burner Air Shutters

DANGER

Failure to adjust air shutters according to directions could cause property damage, personal injury, and or death.

Air shutters are required on propane units, optional on natural units. A slotted screw on the end of the manifold bracket moves air shutters and adjusts all burners simultaneously (See **FIGURE 56**.) Turning the screw clockwise opens the air shutter; counterclockwise closes shutter.

After the furnace has been in operation for 15 minutes, close air shutter until the flame turns yellow. Open shutter until yellow disappears.

FIGURE 56 - Propane Burner Rack Showing Burner Air Shutter Adjustment Screw

Burner Air Shutter Adjustment Screw

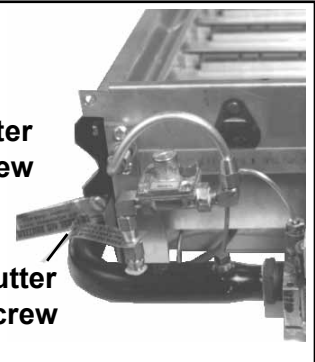

9.0 Check Installation and Start-Up

9.1 Check the installation prior to start-up:

- Verify suspension/mounting methods and clearances. See Paragraphs 4.0 & 5.0.
- Check the duct connection. See Paragraph 6.4.
- Check venting. See Paragraph 6.2. Be sure that flue discharge and combustion air openings are free of obstructions. Be sure electrical entrance and gas supply pipe openings are sealed.

Electrical Checks:

- Be certain the electrical supply matches voltage rating of the furnace. (Refer to the rating plate.)
- Check all field wiring against the wiring diagram. Be sure that wire gauges are as required for the electrical load.
- Check that fuses or circuit breakers are in place and sized correctly.
- Option AG41 or AG42 - set the heat stage controllers. See Paragraph 8.7.4.

Gas Supply Checks:

- Check piping for leaks and proper gas line pressure. Bleed gas lines of trapped air. See Paragraph 6.1.
 - a) Turn manual shutoff valve to off position.
 - b) Turn gas supply on.
 - c) Observe gas meter for movement, or
 - d) Attach pressure gauge readable to .1" w.c. and after turning gas on for ten seconds, turn gas supply off. No change in pressure should occur over a three-minute period.
 - e) If either c) or d) above indicate a leak, locate leak by brushing a soapy solution on all fittings. Bubbles will appear at a leak. Repair and repeat tests.

Blower Checks:

- Check blower pulley and motor pulley to be sure they are secure to the shafts. Check belt tension and alignment. Check blower rotation. See Paragraph 6.5.
- With optional dampers - Check damper linkage. See Paragraph 6.3.3.

9.2 Start-Up

- Close all panels tightly. Turn electric and gas supply on to the furnace. Adjust the thermostat or ductstat so that a call for heat exists. Observe for complete sequencing of safety pilot and ignition.

Operating Sequence

1. Set the thermostat switch at its lowest setting.
2. Turn on power.
3. Turn on the manual gas valves.
4. Set thermostat at desired setting.
5. Thermostat calls for heat
 - a) The venter motor is energized after 15-second (approximate) time delay.
 - b) Venter flow switches from N.C. to N. O. contacts, energizing the pilot gas valve and spark gap to produce a pilot flame on each operating cycle. The sensing probe proves the presence of the pilot flame and energizes the safety switch portion of the control. The switch action de-energizes the spark gap and energizes the main valve. The main gas ignites and the unit fires at full rate.
 - c) If the flame is extinguished during main burner operation, the safety switch closes the main valve and recycles the spark gap. On a unit equipped with a controller with lockout, if the pilot is not established within 120 seconds (approximately), the unit locks out for one hour, unless reset by interrupting the power to the control circuit (See Lighting Instructions).
6. Blower motor operates from fan time delay.
7. Thermostat is satisfied.
 - a) Solenoid gas valve de-energized.
 - b) Pilot gas valve de-energized.
 - c) Ignition controller de-energized.
 - d) Time delay relay keeps venter motor on for approximately 90 seconds (post purge).
8. To shut down, set thermostat to lowest setting. Blower motor remains on as determined by fan time delay.

9.3 Check installation after Start-up:

- Observe burner flame at full fire. Natural gas flame should be about 1-1/2" in height with blue coloring. Propane gas flame should be approximately the same length with blue coloring. Yellow tipping may appear on propane gas. If yellow extends beyond 1/2 to 3/4", adjust air shutters. See Paragraph 8.11. If shutter adjustment will not reduce yellowing, check for gas leaks at the control manifold or orifice fitting.
- Turn the unit off and on, pausing two minutes between each cycle. Observe for smooth ignition. On two-stage or modulating burner systems, manipulate temperature adjustment slowly up and down to see if control is sequencing or modulating properly. Raising temperature setting drives burner on or to full fire.
- Using a manometer or slant gauge readable up to 14" w.c., check orifice manifold for operating pressure on full fire. Natural gas should be 3.5" w.c. at this point. Propane gas should be 10" w.c. at this point. Variations from these pressures are not recommended, as ignition and efficiency performance can be adversely affected by improper pressure adjustment. See Paragraph 6.1.
- With optional dirty filter switch - Set switch. See Paragraph 6.3.4.
- Place "Owner's Envelope" containing Limited Warranty Card, this booklet, and any optional information in an accessible location near the heater. Follow the instructions on the envelope.

DANGER

The gas burner in this gas-fired equipment is designed and equipped to provide safe, complete combustion. However, if the installation does not permit the burner to receive the proper supply of combustion air, complete combustion may not occur. The result is incomplete combustion which produces carbon monoxide, a poisonous gas that can cause death. Safe operation of separated-combustion, indirect-fired gas burning equipment requires a sealed, properly operating vent system which vents all flue products to the outside atmosphere. FAILURE TO PROVIDE PROPER VENTING WILL RESULT IN A HEALTH HAZARD WHICH COULD CAUSE SERIOUS PERSONAL INJURY OR DEATH.

Install either the horizontal or vertical combustion air/vent system illustrated in Paragraph 6.2 using the concentric adapter supplied. Always comply with the combustion air requirements in the installation codes and instructions. Combustion air at the burner should be regulated only by manufacturer-provided equipment. NEVER RESTRICT OR OTHERWISE ALTER THE SUPPLY OF COMBUSTION AIR TO ANY HEATER. CHECK THE COMBUSTION AIR/VENT SYSTEM FOR SOUNDNESS AND FUNCTION; MAINTAIN IT IN PROPER OPERATING CONDITION.

10.0 Maintenance and Service

WARNING

If you turn off the power supply, turn off the gas. See Hazard Levels, page 2.

This unit will operate with a minimum of maintenance. To ensure long life and satisfactory performance, a furnace that is operating under normal conditions should be inspected every four months. If the furnace is operating in an area where an unusual amount of dust or soot or other impurities are present in the air, more frequent inspection is recommended. When servicing, follow standard safety procedures as well as those specific instructions and warnings mentioned in this manual.

10.1 Maintenance Schedule

The following procedures should be carried out at least annually (See paragraphs listed and Paragraphs 10.2.1-10.2.6 for instructions).

- Inspect the filters. Clean or replace as needed. See Paragraph 6.3.2.
- Check the blowers and belts. Check belts for tension, wear, and alignment. Adjust or replace as needed. Clean dirt from blower and motor. See Paragraph 6.5.
- Check the gas valve to ensure that gas flow is being shut off completely.
- Clean the heat exchanger both internally and externally.
- Check the pilot burner and main burners for scale, dust, or lint accumulation. Clean as needed.
- Check the vent/combustion air system; inspect all joints. Replace any parts that do not appear sound.
- Check the wiring for any damaged wire. Replace damaged wiring. (See Paragraph 7.0 for wiring requirements.)

CAUTION: When cleaning, wearing eye protection is recommended.

NOTE: Use only factory-authorized replacement parts.

10.2 Maintenance Procedures

10.2.1. Operating Gas Valve

WARNING

The operating valve is the prime safety shutoff. All gas supply lines must be free of dirt or scale before connecting to the unit to ensure positive closure. See Hazard Levels, page 2.

Remove external dirt accumulation and check wiring connections.

The combination gas valve must be checked annually to ensure that the valve is shutting off gas flow completely.

Instructions:

- 1) Locate the 1/8" FPT INLET pressure tap on the combination valve (FIGURE 57).

FIGURE 57 - Connect manometer to inlet pressure tap to check gas flow shutoff.

Single-Stage Valve

1/8" INLET Pressure Tap



1/8" Outlet Pressure Tap

Two-Stage Valve

1/8" INLET Pressure Tap

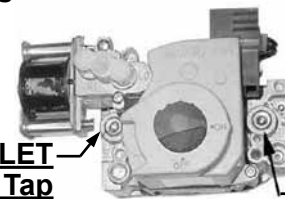

1/8" Outlet Pressure Tap

- 2) With the manual valve turned off to prevent flow to the gas valve, connect a manometer to the 1/8" inlet pressure tap in the valve. **NOTE:** A manometer (fluid-filled gauge) with an inches water column scale is recommended.
- 3) With the field-installed manual valve remaining closed, observe the manometer for two to three minutes for an indication of gas pressure. No pressure should be indicated on the manometer.
If the manometer indicates a gas pressure, the field-installed manual gas valve must be replaced or repaired before the combination gas valve can be checked.
- 4) **If the manometer does not indicate gas pressure,** slowly open the field-installed manual gas valve. After the manometer's indicated gas pressure has reached

equilibrium, close the manual shutoff valve. Observe the gas pressure. There should be no loss of gas pressure on the manometer. If the manometer indicates a loss of pressure, replace the combination gas valve before placing the heater in operation.

NOTE: Operational pressure settings and instructions for checking pressure settings are in Paragraph 6.2.

10.2.2 Pilot and Main Burners

CAUTION: When cleaning, wearing eye protection is strongly recommended.

Burner Rack Removal Instructions

Instructions apply to all furnace sections.

1. Turn off the gas supply.
2. Turn off the electric supply.
3. Remove control access side panel.
4. Disconnect the pilot tubing and flame sensor lead (spark pilot).
5. Mark and disconnect electric valve leads.
6. Uncouple the union in the gas supply.
7. Remove sheetmetal screws in the top corners of the burner rack assembly.
8. Pull "drawer-type" burner rack out of the furnace.

To disassemble the burner rack:

1. Remove Carryover System --

Natural Gas - Remove the flash carryover system from the "manifold end" of the burner rack. **NOTE:** Natural gas burner racks manufactured prior to Series 6 have a lighter tube carryover system. Break the lighter tube connection at the orifice and remove the supply tubing, the drip shield and the lighter tube.

Propane - Break the lighter tube connection at the regulator and remove the lighter tube orifice supply tubing; remove the retaining screws in the drip shield and the shield; remove the retaining screws and slide out the lighter tube.

2. Pull main burners horizontally away from injection opening and lift out.
3. Remove manifold bracket screws and remove manifold.
4. Change main burner orifices, if necessary.
5. Remove screws and lift out pilot burner.

Follow the instructions to clean. To re-assemble and replace, reverse the above procedures being careful not to create any unsafe conditions.

Cleaning Pilot and Main Burners

In the event the pilot flame is short and/or yellow, check the pilot orifice for blockage caused by lint or dust accumulation. Remove the pilot orifice and clean with air pressure. **DO NOT REAM THE ORIFICE.** Check and clean the aeration slot in the pilot burner.

Clean the metal sensing probe and the pilot hood with an emery cloth and wipe off the ceramic insulator. Check the spark gap; spark gap should be maintained to .100". (Refer to **FIGURE 58.**) After the pilot is cleaned, blow any dirt away with compressed air.

Main burners may be cleaned using air pressure. Use an air nozzle to blow out scale and dust accumulation from the burner ports. Alternately blow through the burner ports and the venturi. Use a fine wire to dislodge any stubborn particles. Do not use anything that might change the port size.

Clean the burner rack carryover systems with air pressure.

Pilot and Spark Ignition System

The ignition controller provides the high voltage spark to ignite the pilot service and also acts as the flame safety device. After ignition of the pilot gas, the controller electronically senses the pilot flame. A separate solid metal probe in the pilot burner assembly is used to sense the flame. A low voltage DC electrical signal is imposed on the metal probe which is electrically insulated from ground. **Proper operation of the electronic spark ignition system requires a minimum flame signal of .2 microamps DC as measured by a microammeter.** When the pilot flame impinges on the sensing probe, the flame acts as a conduction path to ground. This completes the DC circuit; the ignition controller responds by energizing the main gas valve.

CAUTION: Due to high voltage on pilot spark wire and pilot electrode, do not touch when energized. See Hazard Levels, 2.

10.0 Maintenance and Service (cont'd)

10.2 Maintenance Procedures (cont'd)

FIGURE 58 - Pilot Assembly Spark Gap

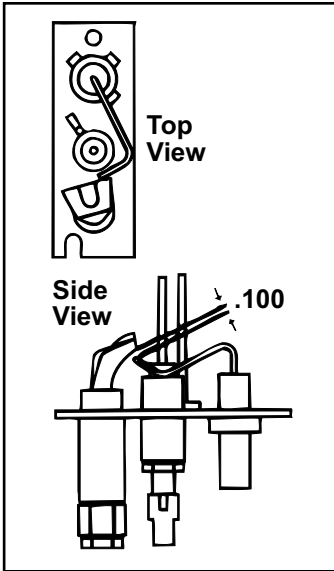

10.2.2 Pilot and Main Burners (cont'd)

Pilot and Spark Ignition System (cont'd)

If no spark occurs, check the following:

- a) Voltage between Terminals TH and 7 on the ignition controller should be at least 20 volts and no higher than 32 volts. Refer to Troubleshooting (Paragraph 10.3) if no voltage is observed.
- b) Short to ground in the high tension lead and/or ceramic insulator.
- c) Pilot spark gap should be approximately .100".

NOTE: When checking for spark with the pilot burner assembly removed from the burner rack, the pilot assembly must be grounded to the heater for proper spark.

If the above conditions are normal and no spark occurs, replace the ignition controller. (See controller illustration and replacement information on page 51.)

If the main gas valve fails to open with a normal full size pilot flame established, check for the following:

- a) If voltage between black and brown leads on the main gas valve is 20 to 32 VAC and there is no main gas flow with the built-in manual valve in FULL OPEN position, the main valve is defective.
- b) If there is no voltage between black and brown leads on the main gas valve, check for disconnected or shorted flame sensor lead or flame sensor probe.

When the above conditions are normal and the main gas flow is still off, the ignition controller is probably defective. Do not attempt to service the ignition controller; it does not contain any replaceable components.

10.2.3 Cleaning the Heat Exchanger

To clean the inner surfaces of the heat exchanger, remove the burner rack assembly (See Paragraph 10.2.2.) permitting access to the inside of the heat exchanger tubes.

Clean the tubes using a 1/2" diameter furnace brush. A mirror and flashlight are helpful in examining the narrow section of each tube. Remove any accumulated dust and soot.

10.2.4 Venter Motor

Power venter motors are permanently lubricated. No oiling is required.

10.2.5 Blower, Belt, and Drive

Check blower pulley and motor pulley to be sure they are secure to the shaft. Check belt condition and belt tension (See Paragraph 6.5).

Blower Bearings - The blower bearings on models with less than a 10 HP motor (standard blower) are permanently lubricated cartridge ball bearings and do not require greasing.

The blower bearings on models equipped with a 10-20 HP motor are pillow block ball bearings and are equipped with a grease fitting. These bearings should be lubricated twice a year with a high temperature, moisture-resistant grease. (Type NLGI-1 or -2 standard grease is recommended.) Be sure to clean the grease fitting before adding grease.

Add grease with a handgun until a slight bead of grease forms at the seal. Be careful not to unseat the seal by over lubricating. **NOTE:** If unusual environmental conditions exist (temperatures below 32°F or above 200°F; moisture; or contaminants), more frequent lubrication is required.

CAUTION: If the blower is unused for more than three months, bearings with a grease fitting should be purged with new grease prior to startup.

10.2.6 Limit Control Check

With the heater on, completely block off the distribution air. The limit control should open within a few minutes, shutting off gas supply to the main burners.

10.3 Troubleshooting

TROUBLE	PROBABLE CAUSE	REMEDY
Venter motor will not start	1. No power to the furnace.	1. Turn on power, check supply fuses or circuit breaker.
	2. No 24-volt power to venter relay.	2. Turn up thermostat, check control transformer output. Check for loose or improper wire connections.
	3. Venter relay defective.	3. Replace.
	4. Defective motor or capacitor.	4. Replace defective part.
Pilot will not light -- Venter operating	1. Manual valve not open.	1. Open manual valve.
	2. Air in gas line.	2. Bleed gas line.
	3. Dirt in pilot orifice.	3. Remove and clean with compressed air or solvent.
	4. Gas pressure too high or too low.	4. Adjust supply pressure. (See Paragraph 6.1).
	5. Kinked pilot tubing.	5. Replace tubing.
	6. Pilot valve does not open.	6. If 24 volts available at the valve, replace valve.
	7. No spark:	7.
	a) Loose wire connections	a) Be certain all wires connections are solid.
	b) Transformer failure.	b) Be certain 24 volts is available.
	c) Incorrect spark gap.	c) Maintain spark gap at .100".
	d) Spark cable shorted to ground.	d) Replace worn or grounded spark cable.
	e) Spark electrode shorted to ground.	e) Replace pilot if ceramic spark electrode is cracked or grounded.
	f) Drafts affecting pilot.	f) Make sure all panels are in place and tightly secured to prevent drafts at pilot.
	g) Ignition control not grounded.	g) Make certain ignition control is grounded to furnace chassis.
h) Faulty ignition controller.	h) If 24 volt is available to the ignition controller and all other causes have been eliminated, replace ignition control.	
8. Optional lockout device interrupting control circuit by above causes.	8. Reset lockout by interrupting control at thermostat.	
9. Faulty combustion air proving switch.	9. Replace combustion air proving switch.	
Pilot lights, main valve will not open	1. Manual valve not open.	1. Open manual valve.
	2. Main valve not operating.	2.
	a) Defective valve.	a) If 24 volt is measured at valve connections and valve remains closed, replace valve.
	b) Loose wire connections.	b) Check and tighten all wiring connections.
	3. Ignition control does not power main valve.	3.
	a) Loose wire connections.	a) Check and tighten all wiring connections.
	b) Flame sensor grounded. (Pilot lights - spark continues)	b) Be certain flame sensor lead is not grounded or insulation or ceramic is not cracked. Replace as required.
	c) Gas pressure incorrect.	c) Adjust gas pressure. (See Paragraph 6.1.)
	d) Cracked ceramic at sensor.	d) Replace sensor.
	e) Faulty ignition controller.	e) See Paragraph 10.2.2. If all checks indicate no other cause, replace ignition controller. Do not attempt to repair the ignition controller. This device has no field replaceable parts.
No heat (Heater operating)	1. Dirty filters in blower system.	1. Clean or replace filters.
	2. Incorrect manifold pressure or orifices.	2. Check manifold pressure (See Paragraph 6.1).
	3. Cycling on limit control.	3. Check air throughput.
	4. Improper thermostat location or adjustment.	4. See thermostat manufacturer's instructions.
	5. Belt slipping on blower	5. Adjust belt tension
Cold air - On startup/ during operation	1. Fan control improperly wired	1. Connect as per wiring diagram.
	2. Defective fan control.	2. Replace fan control.
	3. Incorrect manifold pressure.	3. Check manifold line pressure (See Paragraph 6.1).
	4. Blower set for too low temperature rise.	4. Slow down blower or increase static pressure. (See Paragraph 6.5.)
Motor will not run	1. Circuit open	1. Check wiring and connections.
	2. Fan control inoperative	2. Replace fan control.
	3. Contactor inoperative	3. Replace contactor.
	4. Defective motor.	4. Replace motor.
Motor turns on and off while burner is operating (see below)	1. Fan control heater element improperly wired.	1. Connect as per wiring diagram.
	2. Defective fan control	2. Replace fan control.
	3. Motor overload device cycling	3. Check motor load against motor rating plate. Replace motor or overload device.
	4. 3-phase motor rotating in opposite direction	4. Interchange two legs of supply connections.
Motor cuts out on overload	1. Improper motor pulley adjustment	1. See instructions on air throughput (See Paragraph 6.5).
	2. Improper static pressure on duct system	2. Adjust dampers in duct system.
	3. Low voltage	3. Check power supply.

INDEX

A

Optional Airflow Proving Switch 44
Ampere Rating 42

B

Blower Bearings 56
Belts 39
Belt tension 39
Adjusting Blower Speed 39
Blower Rotation 40
Blowers 39
Brackets for Attaching the Concentric Adapter Box 20, 23
Burner Air Shutters 52
Burner Carryover Systems 51
Burner Orifices 52
Burner Rack Removal 55
Burners 51

C

Check Installation and Start-Up 52
Check Valve Outlet 14
Chlorine 4
Cleaning Pilot and Main Burners 55, 56
Cleaning the Heat Exchanger 56
Clearance 17
Clearances 8
Clearances to a Horizontal Vent Terminal 19
Optional Cooling Coil Cabinet 34
Combustion Air Inlet 22
Combustion Air Inlet Pipe 15
Combustion Air Proving Switch 44
Components 22
Concentric Adapter Box 15, 17
Concentric Adapter Box Airflow 17
Package Configurations 4
Connections at the Concentric Adapter Box 18
Contact 60
Locations of Standard and Optional Controls 43
Control Wiring 42
Cooling Coil Maintenance 38
Cross Support 9

D

Inlet Air Damper Linkage 28
Optional Dampers and Controls 28

Dimensions 5
Mounting Support Dimensions 9
Roof Curb Dimensions 11
Dimensions - Concentric Adapter Box 17
Dimensions - Optional Cooling Coil Cabinet 7
Dirty Filter Switch 31
Disconnect Switch 42
Distributor 60
Drives 39
Duct Connections 38
Ductstat 46

E

Electrical Supply and Connections 41
Optional Electronic Modulation 47
Electronic Modulation between 25-100% Firing Rate 48
Electronic Modulation between 50% and 100% 47
enlarger 15
Optional Evaporative Cooling Module 31
Evaporative Cooling Media 32
Exhaust (Vent) Terminal 22

F

Fan Control 43
Optional Filter Rack and Filters 29
Float Switch 34

G

Gas Connection 13
Gas Controls 44
Gas Piping and Pressures 13
Gas Supply Lines 14
Gas Valve 54

H

Hazard Labels 2
Horizontal Vent Instructions 19, 20
Horizontal Vent Kit 19
Horizontal Vent Kit Option CC6 19

I

Ignition Controller 51
Ignition System 51
Inlet Guard 19
Installation Codes 3
Installation Information 3
Installation Instructions for Horizontal Vent Kit 19
Installation Instructions for

Vertical Vent Kit 22
Installation of Model SSCBL with Vertical Vent 25
INSTALLATION RECORD 60
Installer 60

J

join Double-Wall (Type B) Pipe and the Vent Terminal Cap 16
join the Double-Wall (Type B) Pipe to the Taper-type Reducer 17

L

Optional High Ambient Limit Control 44
Limit Control 44
Limit Control Check 56
Furnace Location 3

M

Manifold) Pressure 14
Manifold or Orifice (Valve Outlet) Pressure Settings 14
Model 60
Motor 41
Mounting 8
Mounting Outdoor Models 9, 12

O

100% Outside Air Hood 26

P

Pilot 51
Pilot and Ignition Systems 51
Pipe Diameter and Length 15, 16
Pressure Null Switch 28
Blower Pulley 40

R

reducer 15
Remote Console 42
Reverse Flow, Limit Control 44
Roof Curb 10
Roof Curb Assembly and Installation 12

S

Screened Air Hood for 30% Outside Air Opening 27
Screened Exhaust Assembly 19
Duct Temperature Sensor 47
Serial No. 60
Set Heat Stage Controllers 49
Shipped-Separate

Components 4
Spark Gap 56
Stage-Adder Module 46
Stage Adder Module 4
Start-Up 53
Supply Voltage and Wiring 41
Support 17
Support Rod Detail 8
Suspension 8
Control Switch 4

T

Remote Temperature Selector 4, 46
Thermostat 4
Troubleshooting 57
Optional Two-Stage Operation - Heating 45
Typical Separated-Combustion Unit with Horizontal 21

U

Uncrating 4

V

Valve 44, 54
Optional Variable Frequency Drive 41
Vent/Combustion Air Terminal Kit 5
Venter Motor 56
Venter Outlet 15
Horizontal Vent Terminal/Combustion Air Package (O 19)
Venting and Combustion Air 15, 16
Venting Requirements 15
Vent Pipe 15
Vertical Flue Discharge (Option CC3) 25
Vertical Vent Instructions 22, 24
Vertical Vent Kit 22

W

Warranty 3

INSTALLATION RECORD - to be completed by the installer:

Installer:

Name _____
Company _____
Address _____

Phone _____

Distributor (company from which the unit was purchased):

Company _____
Contact _____
Address _____

Phone _____

Model _____ Serial No. _____ Date of Installation _____

SPECIFIC INSTALLATION NOTES: (i.e. Location, Amps, Gas Pressure, Temperature, Voltage, Adjustments, Warranty, etc.)

BUILDING OWNER OR MAINTENANCE PERSONNEL:

For service or repair

- Contact the installer listed above.
- If you need additional assistance, contact the Reznor® Distributor listed above.
- For more information, contact your Reznor® Representative by calling 800-695-1901.

Reznor
150 McKinley Avenue
Mercer, PA 16137

www.ReznorHVAC.com; (800) 695-1901

©2015 Reznor LLC, All rights reserved.

Trademark Notes: Reznor® is registered in at least the United States. All other trademarks are the property of their respective organizations.
5/15 Form I-SSCBL/RPBL (Version E.3)

REZNOR®

Form I-SSCBL/RPBL, P/N 149159 R8, Page 60