

# REZNOR®

## INSTALLATION INSTRUCTIONS

FORM RZ-NA-I-XBWU  
MAY 29, 2014  
SUPERCEDES 09-27-13  
OXX-2XERV

ENERGY RECOVERY VENTILATOR

Applies to Model XBWU

### INSTALLATION INSTRUCTIONS FOR ROOFTOP STAND ALONE ENERGY RECOVERY UNIT IN OVER/UNDER DESIGN



Energy recovery COMPONENT certified to the AHRI Air-to-Air Energy Recovery Ventilation Equipment Certification Program in accordance with AHRI Standard 1060-2000. Actual performance in packaged equipment may vary.



ETL Certified per UL 1995 and CSA 22.2

#### I - Shipping And Packing List

Package contains:

- 1 - Energy Recovery Ventilator Assembly

#### II - Shipping Damage

Check unit for shipping damage. Receiving party should contact last carrier immediately if shipping damage is found.

#### III - General

These instructions are intended as a general guide and do not supersede local codes in any way. Authorities having jurisdiction should be consulted before installation.

#### IV - Requirements

When installed, the unit must be electrically wired and grounded in accordance with local codes or, in absence of local codes, with the current National Electric Code, ANSI/NFPA No. 70.

#### V - Application

These Energy Recovery Ventilators (ERV) are used in a down discharge manner equipped with field provided balancing damper assembly through the roof. A roof curb must be provided to Rooftop Systems specifications. These wheels conserve energy by mixing warmer air with cooler air in the following manner:

#### Recovery Wheel Mode

The Recovery Wheel mode is accomplished by two blowers providing continuous exhaust of stale indoor air and replacement by equal amount of outdoor air. Energy recovery is achieved by slowly rotating the energy recovery wheel within the cassette frame work. In winter, the ERV adsorbs heat and moisture from the exhaust air stream during one half of a complete rotation and gives them back to the cold, drier intake air supply during the other half rotation. In summer, the process is automatically reversed. Heat and moisture are absorbed from incoming fresh air supply and transferred to the exhaust air stream. This process allows outdoor air ventilation rates to be increased by factors of three or more without additional energy penalty or increase in size of heating or air conditioning systems.

#### VI - Rigging Unit For Lifting

1. Maximum weight of unit is — Varies per Series {300-1200 Lbs.} (Crated)
2. Remove crating.
3. All panels must be in place for rigging.
4. Remove barometric exhaust hood from door marked filter access. Install barometric exhaust hood over exhaust blower outlet.

5. Duct work should be installed into roof curb before installing ERV on curb.
6. Roof curb gasket must be applied to all top surfaces of the curb.
7. Forklift channels must be removed from the base of ERV before setting unit on curb. **See Figure 1.**
8. Position unit on roof curb and provide service access to ERV control access door and wheel.

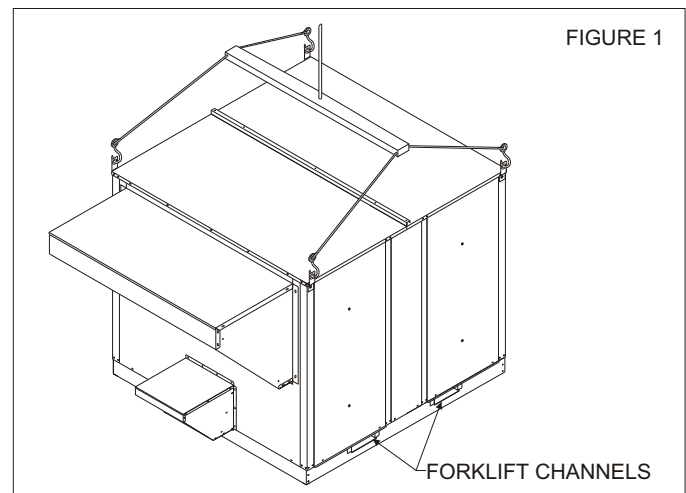

### CAUTION

Danger of sharp metallic edges. Can cause injury. Take care when servicing unit to avoid accidental contact with sharp edges.

#### VII - Installation

1. Attach duct work to duct flanges on roof curb.
2. Remove forklift channels from base of ERV.
3. Set ERV on curb. Verify ERV is positioned on curb properly.

### WARNING



Electric shock hazard. Can cause injury or death. Before attempting to perform any service or maintenance, turn the electrical power to unit OFF at disconnect switch(es). Unit may have multiple power supplies.

4. Remove barometric exhaust hood from door marked filter access. Install barometric exhaust hood over exhaust blower outlet.
5. Remove ERV control access panel to connect field wiring.
6. Route class II low voltage wire (3 conductor) from thermostat or energy management through small bushing in end panel of ERV. **See wiring diagram.**
  - a. Thermostat (dependent) - connect in parallel at rooftop unit with "G", "C" and "W". Then connect matching color at terminal 1, 2, and 3 respectively on ERV circuit board.
  - b. Energy Management - provide +24 VAC to "1" and common, 24 VAC to "2" terminals on ERV circuit board.
  - c. Thermostat (dedicated) - splice into +24 vac (blue wire) at (control circuit board) transformer connection run wire to "R" terminal. Then run another wire from "G" terminal to ERV (control circuit board) terminal block #1.
7. All electrical connections must conform to any local codes and current National Electric Codes (NEC) and Canadian Electric Codes (CEC). Refer closely to unit wiring diagram in unit and/or in these instructions for proper wiring connections.
8. Refer to the unit nameplate for minimum circuit ampacity (MCA) and maximum overcurrent protection size (fuse).
9. Electrical data is listed on unit rating plate and motor name plates.
10. Connect line voltage power supply to ERV fuse block in control box of unit from disconnect switch. **See wiring diagram.**
11. Ground unit with a suitable ground connection either through unit supply wiring or an earth ground.

**Note: Unit voltage entries must be sealed weather tight after wiring is complete.**

12. Remove motor access panels. Locate belts fastened to blower assembly. Install belt onto motor and blower pulley. Adjust motor sheave to correct blower RPM for CFM and external static pressure requirements. See charts in this instruction. Multiple pulley arrangements are available to meet the entire range.

**Caution: Blower speed must be adjusted for the given external static pressure and airflow (CFM) requirements. If blower speed is not adjusted for conditions, possible motor over loading can occur.**

13. Replace access panel onto the ERV unit and secure.
14. Restore power to unit.
15. Cleanup once unit is operating properly, caulk any open joints, holes or seams to make the unit completely air and water tight.
16. Leave this instruction manual with owner or in an envelope to be kept near unit.

## VIII - Operation

### How It Works

The unit contains an Energy Recovery Wheel (ERW) that is a new concept in rotary air-to-air heat exchangers. Designed as a packaged unit for ease of installation and maintenance, only the connection of electrical power is required to make the system operational.

When slowly rotating through counter flowing exhaust and fresh air streams the ERW adsorbs sensible heat and

latent heat from the warmer air stream and transfers this total energy to the cooler air stream during the second half of its rotating cycle. Rotating at 50-60 revolutions per minute, the wheel provides constant flow of energy from warmer to cooler air stream. The large energy transfer surface and laminar flow through the wheel causes this constant flow of recovered energy to represent up to 85% of the difference in total energy contained within the two air streams.

Sensible and latent heat are the two components of total heat. Sensible heat is energy contained in dry air and latent heat is the energy contained within the moisture of the air. The latent heat load from the outdoor fresh air on an air conditioning system can often be two to three times that of the sensible heat load and in the winter it is a significant part of a humidification heat load.

During both the summer and winter, the ERW transfers moisture entirely in the vapor phase. This eliminates wet surfaces that retain dust and promote fungal growth as well as the need for a condensate pan and drain to carry water.

Because it is constantly rotating when in the air stream, the ERV is always being cleaned by air, first in one direction then the other. Because it is always dry, dust or other particles impinging on the surface during one half cycle, are readily removed during the next half cycle.

During the heating season, when outdoor air temperatures are below 15°F, it is recommended to use the (optional) low ambient kit (field installed).

Low Ambient Kit is appropriate for climates with limited HVAC system operation when outdoor temperatures are below 10°F.

The frost threshold is the outdoor temperature at which frost will begin to form on the ERV wheel. For Energy Recovery Ventilators, the frost threshold is typically below 10°F. Frost threshold is dependent on indoor temperature and humidity. The table shows how the frost threshold temperatures vary depending on indoor conditions.

FROST THRESHOLD TEMPERATURE	
INDOOR RH AT 70°F	FROST THRESHOLD TEMPERATURE
20%	0°F
30%	5°F
40%	10°F

Because Energy Recovery Ventilators have a low frost threshold, frost control options are not necessary in many climates. Where outdoor temperatures may drop below the frost threshold during the ERV operational hours, exhaust only frost control option is available.

### Low Ambient Kit (Optional)

Low Ambient Kit turns off the supply blower when outdoor temperatures fall below the frost threshold. The exhaust only thermostat set points are field adjustable. Supply fan operation is automatically restored when the exhaust air temperature rises above the thermostat set point. Provisions for introducing make-up air into the building when the supply blower is off to avoid depressurization should be considered.

### Recovery Wheel Mode

On a thermostat call for blower operation in heating, cooling or continuous blower, the ERW will rotate between fresh air and exhaust air streams. Both the fresh air and exhaust air blowers will also be operating to overcome the air resistance of the ERV.

## IX - System Check

1. Disconnect main power.

2. Turn to "Cont" for blower operation on thermostat controlled models.
3. Restore power to unit. Observe ERV wheel rotation and both fresh air and exhaust air blowers while operating.

**Note: If Low ambient kit is used the jumper between TB37-5 & TB37-6 should be removed. Also if system check out is being conducted at low ambient temperatures, technician should be aware that this kit can cause system not to operate.**

4. Verify that the ERV (3) three phase blower motors are phased sequentially ensuring correct rotation and operation.
  - a - Disconnect power.
  - b - Reverse any two field power leads to the ERV.
  - c - Reapply power.
5. Verify that both blower motors are operating under their full load AMP rating (FLA). The FLA can be found on each motor and the unit nameplate

#### A - Return Damper Settings

Manually adjust position of field installed dampers to balance air flow.

#### B - Air Flow / Blower Speed Adjustment

Blower speed selection is accomplished by changing the sheave setting on both fresh air and exhaust air blowers. To set ERV for the required air flow (CFM), the external static pressure applied to the ERV (duct static) must be known. See the CFM vs External Static Pressure chart for the appropriate unit to determine the correct blower RPM for the specified CFM and External Static Pressure.

After blower speed adjustments have been made. Ensure that when the belt is replaced it is tensioned correctly. The motor mounting plate can be adjusted to tension the belt. If using a belt tension checker, adjust the span to the appropriate setting and check the belt deflection force. The belt deflection force should be between 5-8 lbs or the lowest tension at which the belt will not slip under peak load conditions.

1. Disconnect main power to unit before making adjustment to economizer and/or ERV unit.
2. Replace ERV control access cover.
3. Set thermostat to normal operating position.
4. Restore power to unit.

#### X - Maintenance

1. All motors use prelubricated sealed bearings; no further lubrication is necessary.
2. Make visual inspection of motors, belts and wheel rotating bearings during routine maintenance.
3. Eight pie-shaped segments are seated on stops between the segment retainer which pivots on the wheel rim and is secured to the hub and rim of the wheel. Annual inspection of the self cleaning wheel is recommended. With power disconnected, remove ERV access panels (rear) and unplug [J150 & P150] **(Refer to wiring diagram in this instruction manual)**. Remove segment and wash with water and/or mild detergent.
4. To install wheel segments follow steps A through E . **See Figure 2.** Reverse procedure for segment removal.
  - a. Unlock two segment retainers (one on each side of the selected segment opening).

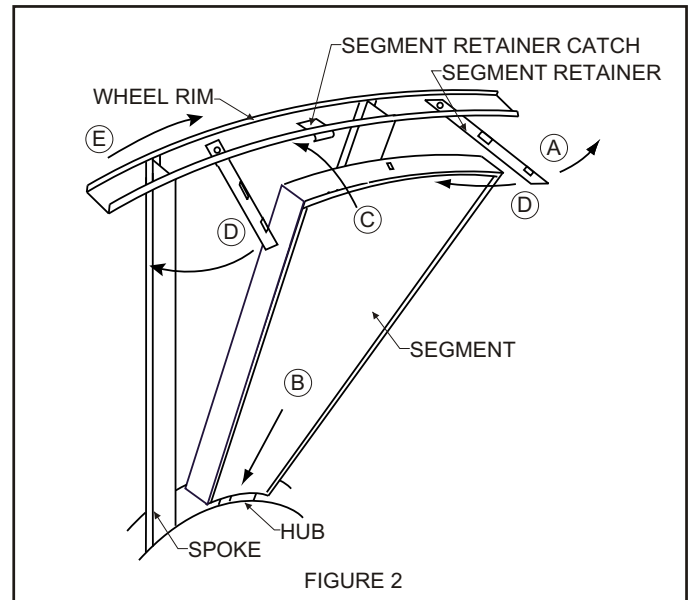

FIGURE 2

- b. With the embedded stiffener facing the motor side, insert the nose of the segment between the hub plates.
- c. Holding segment by the two outer corners, press the segment towards the center of the wheel and inwards against the spoke flanges. If hand pressure does not fully seat the segment, insert the flat tip of a screw driver between the wheel rim and outer corners of the segment and apply downward force while guiding the segment into place.
- d. Close and latch each segment retainer under segment retaining catch.
- e. Slowly rotate the wheel 180°. Install the second segment opposite the first for counterbalance. Rotate the two installed segments 90° to balance the wheel while the third segment is installed. Rotate the wheel 180° again to install the fourth segment opposite the third. Repeat this sequence with the remaining four segments.

#### XI - Pulley Kit Installation

The units are shipped from the factory at the low static setting. Pulley kits are available for the medium and high static settings. To install a pulley kit.

1. Check content of pulley kit, if pulley kit contains:
  - a. An adjustable sheave and a fixed pitch pulley then remove belt and both motor and blower pulley
  - b. An adjustable sheave then remove the motor pulley.
  - c. A fixed pitch pulley then remove the blower pulley.
2. Replace pulley(s) with the pulley(s) from pulley kit. Make sure each pulley is installed with a key. Tighten the set screw on the pulley(s) to 100 in.lb.
3. Install the belt that came with the pulley kit. Tension belt as explained in the blower speed adjustment section.
4. Check the speed of the blower. Adjust the motor sheave to increase or decrease the speed of the blower. See blower adjustment section.

# Stand Alone ERV'S For Over and Under Duct Arrangements

## Features and Notes

1. Stand alone design allows higher levels of outdoor air to be introduced into the conditioned space.
2. Static test ports provided to verify intake and exhaust CFM.
3. Balancing damper(s) is field provided when connected to ductwork. System may not operate properly without balancing damper.
4. Roof curbs are available for the ERV's.
5. See blower performance charts for airflow at various E.S.P.
6. Filter rack with 2" pleated filters included.

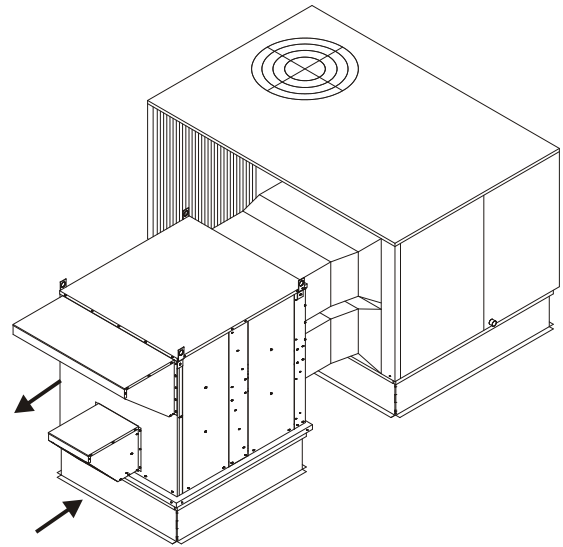

**ERV with Horizontal Ductwork**  
(balancing damper(s) field supplied)

Roof Curbs (Option Codes)		
Size	14"	24"
11	CJ51-11	CJ52-11
20	CJ51-20	CJ52-20
28	CJ51-28	CJ52-28
36	CJ51-36	CJ52-36
46	CJ51-46	CJ52-46
62	CJ51-62	CJ52-62

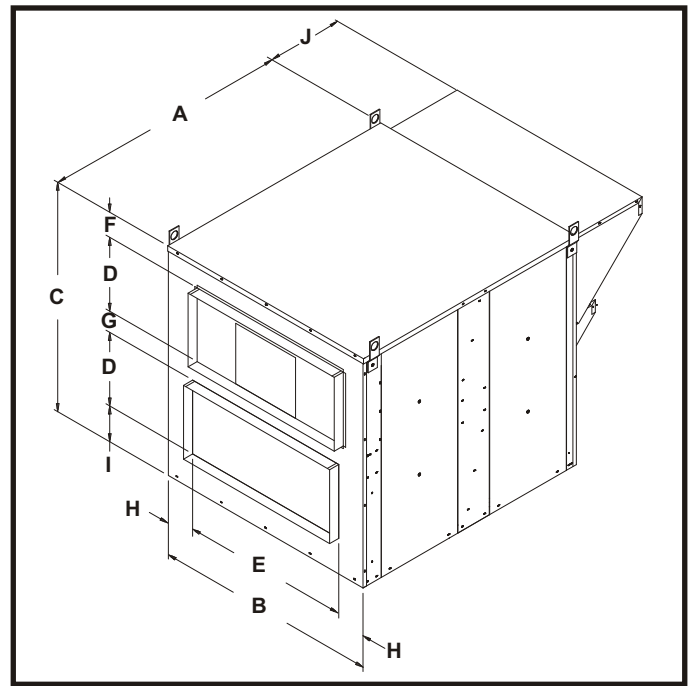
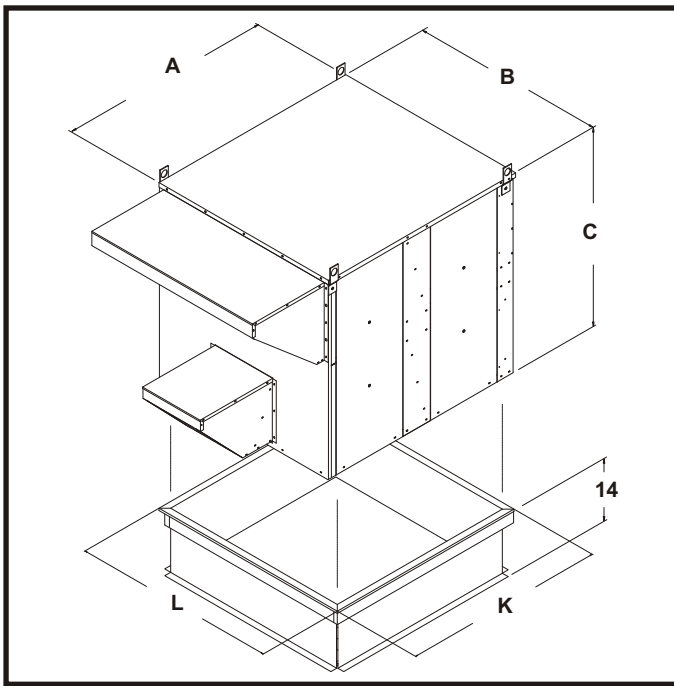

ERV Data		Dimensional Data											
Size	CFM Range	A	B	C	D	E	F	G	H	I	J	K	L
11	300-1100	56.75	32.13	39.50	11.00	27.00	6.50	10.00	2.56	1.00	11.00	55.00	30.25
20	1200-2000	54.38	37.25	37.50	12.00	30.00	8.00	4.00	3.63	1.50	20.32	52.75	35.50
28	1200-2800	60.00	42.62	43.56	14.00	32.00	9.56	4.50	5.31	1.50	18.32	49.50	41.00
36	2000-3600	60.00	46.69	57.37	16.50	39.50	12.13	6.38	3.59	5.88	18.32	55.75	41.81
46	3000-4600	60.00	52.69	57.37	16.50	39.50	12.13	6.38	6.59	5.88	18.32	55.75	47.81
62	4600-6200	72.00	70.88	63.63	19.50	39.50	12.13	6.50	15.69	5.88	18.32	67.75	66.00



**COMPONENT CODE**

A131	Fixed Relay Board	J150	Jack, Wheel Motor Harness	P161	Plug, Damper Exhaust Motor Harness
B26	Motor, Exhaust Air	J151	Jack, Exhaust Air Motor Harness	RS-1	Rotation Sensor (Optional)
B27	Motor, Intake Air	J160	Jack, Damper Intake Motor Harness	S26	Switch, Low Ambient (Optional)
B28	Motor, Desiccant Wheel	J161	Jack, Damper Exhaust Motor Harness	S51	Switch, Door
B30	Motor, Damper Intake (Optional)	K163	Contact, Exhaust Air Motor	S52	Switch, Damper Intake
B31	Motor, Damper Exhaust (Optional)	K164	Contact, Intake Air Motor	S53	Switch, Damper Exhaust
C23	Capacitor, Wheel Motor	MPD-1	Missing Pulse Detector Board (Optional)	SD	Smoke Detector (Optional)
C25	Capacitor, Exhaust Air	P48	Plug, Intake Air Motor Harness	SSJ	Climate Smart Board (Optional)
C26	Capacitor, Intake Air	P50	Plug, Wheel Motor Harness	T27	Transformer, Control
F29	Fuse	P51	Plug, Exhaust Air Motor Harness	T28	Transformer, Step-down (Optional)
J48	Jack, Control Box (Intake Air)	P56	Plug, Damper Motor Harness	TB37	Terminal Block (Low Voltage)
J50	Jack, Control Box (Wheel)	P148	Plug, Intake Air Motor	TB39	Terminal Block (Monitoring)
J51	Jack, Control Box (Exhaust Air)	P150	Plug, Wheel Motor	WHL	Relay, Wheel Motor
J56	Jack, Control Box (Damper)	P151	Plug, Exhaust Air Motor		
J148	Jack, Intake Air Motor Harness	P160	Plug, Damper Intake Motor Harness		

**WIRE COLOR CODE**

BK	Black
BL	Blue
GR	Green
GY	Gray
OR	Orange
PK	Pink
RD	Red
WT	White
YL	Yellow

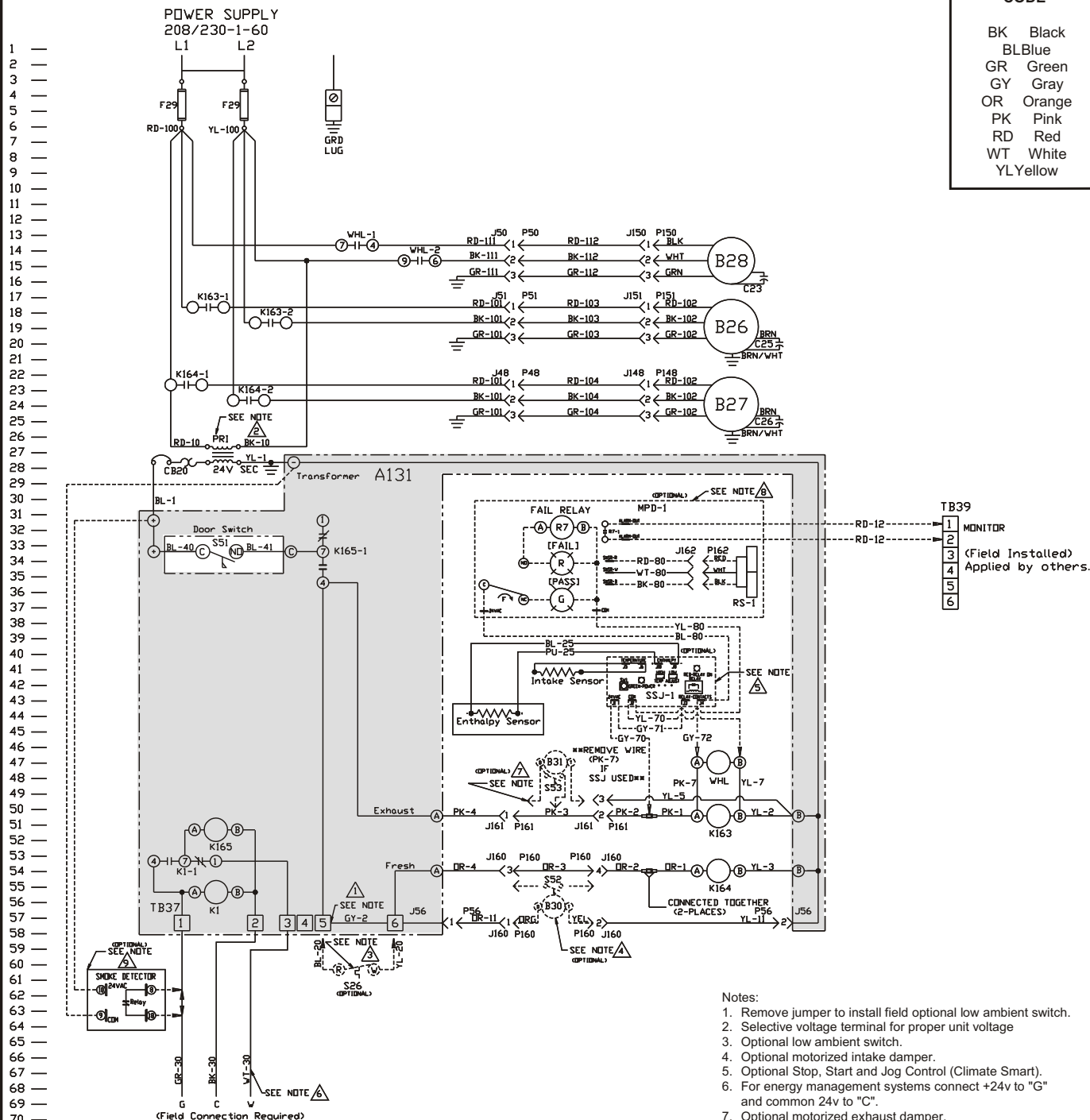

- Notes:
1. Remove jumper to install field optional low ambient switch.
  2. Selective voltage terminal for proper unit voltage
  3. Optional low ambient switch.
  4. Optional motorized intake damper.
  5. Optional Stop, Start and Jog Control (Climate Smart).
  6. For energy management systems connect +24v to "G" and common 24v to "C".
  7. Optional motorized exhaust damper.
  8. Optional wheel rotation sensor.
  9. Optional smoke detector.

O11-21-2ZERV

# ERV UNIT WIRING DIAGRAM

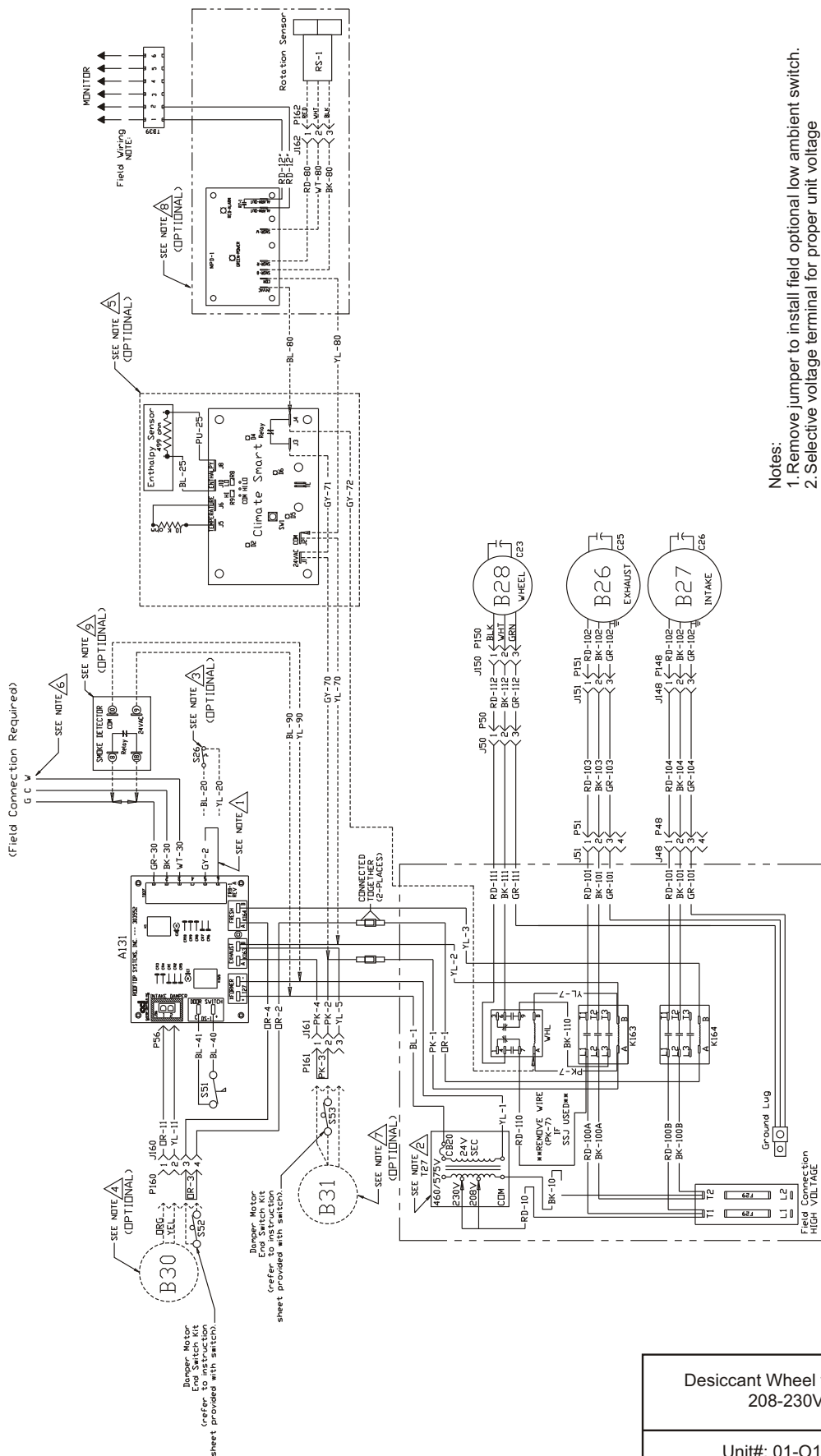

- Notes:
1. Remove jumper to install field optional low ambient switch.
  2. Selective voltage terminal for proper unit voltage
  3. Optional low ambient switch.
  4. Optional motorized intake damper.
  5. Optional Stop Start and Jog Control (Climate Smart).
  6. For energy management systems connect +24v to "G" and common 24v to "C".
  7. Optional motorized exhaust damper.
  8. Optional wheel rotation sensor.
  9. Optional smoke detector.

Desiccant Wheel for Rooftop Unit  
208-230V (1 PH)

Unit#: 01-O11-02XX-21

**COMPONENT CODE**

A131	Fixed Relay Board	J152	Jack, Transformer (High Voltage)	P161	Plug, Damper Exhaust Motor Harness
B26	Motor, Exhaust Air	J160	Jack, Damper Intake Motor Harness	RS-1	Rotation Sensor (Optional)
B27	Motor, Intake Air	J161	Jack, Damper Exhaust Motor Harness	S26	Switch, Low Ambient (Optional)
B28	Motor, Desiccant Wheel	K163	Contact, Exhaust Air Motor	S51	Switch, Door
B30	Motor, Damper Intake (Optional)	K164	Contact, Intake Air Motor	S52	Switch, Damper Intake
B31	Motor, Damper Exhaust (Optional)	MPD-1	Missing Pulse Detector Board (Optional)	S53	Switch, Damper Exhaust
C23	Capacitor, Wheel Motor	P48	Plug, Intake Air Motor Harness	SD	Smoke Detector (Optional)
F29	Fuse	P50	Plug, Wheel Motor Harness	SSJ	Climate Smart Board (Optional)
J48	Jack, Control Box (Intake Air)	P51	Plug, Exhaust Air Motor Harness	T27	Transformer, Control
J50	Jack, Control Box (Wheel)	P56	Plug, Damper Motor Harness	T28	Transformer, Step-down (Optional)
J51	Jack, Control Box (Exhaust Air)	P148	Plug, Intake Air Motor	TB37	Terminal Block (Low Voltage)
J56	Jack, Control Box (Damper)	P150	Plug, Wheel Motor	TB39	Terminal Block (Monitoring)
J148	Jack, Intake Air Motor Harness	P151	Plug, Exhaust Air Motor	WHL	Relay, Wheel Motor
J150	Jack, Wheel Motor Harness	P152	Plug, Transformer (High Voltage)		
J151	Jack, Exhaust Air Motor Harness	P160	Plug, Damper Intake Motor Harness		

**WIRE COLOR CODE**

BK	Black
BL	Blue
GR	Green
GY	Gray
OR	Orange
PK	Pink
RD	Red
WT	White
YL	Yellow

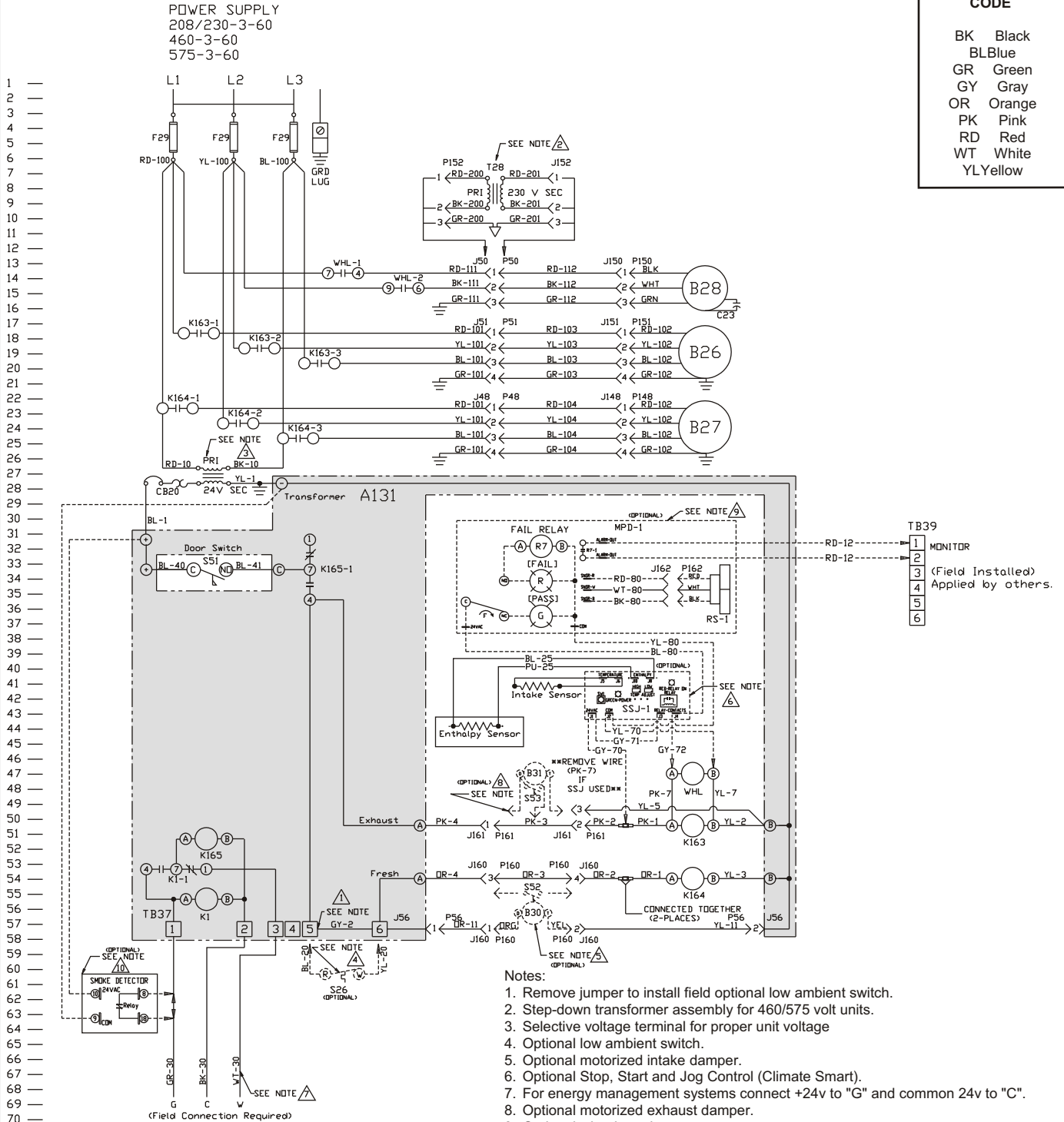

O11-O62-2ZERV





## Blower RPM for XBWU11

### SUPPLY

		Mist Eliminator Filter in Intake Hood (1.5HP)						
		External Static Pressure (in water)						
		0	0.25	0.5	0.75	1	1.25	1.5
CFM	300	N/A	N/A	1175	1350	1450	1605	1730
	500	N/A	1170	1340	1540	1655	1725	1840
	700	1295	1425	1600	1625	1795	1960	2035
	900	1540	1660	1720	1790	2030	2110	2195
	1100	1785	1915	2025	2185	N/A	N/A	N/A

### EXHAUST

		Barometric Hood, 2" Pleated Filters (1.5HP)						
		External Static Pressure (in water)						
		0	0.25	0.5	0.75	1	1.25	1.5
CFM	300	N/A	N/A	1030	1225	N/A	N/A	N/A
	500	N/A	1025	1180	1265	1425	1535	N/A
	700	1120	1190	1340	1445	1540	1645	1720
	900	1285	1525	1500	1575	1670	1785	1865
	1100	1570	1665	1670	1775	1860	1920	N/A

Notes:

1. Drive losses included in the above tables.
2. Performance can vary depending on ambient conditions
3. Blower RPMs are for reference only

		RPM Range		
	Low	1000-1300	Standard Unit	
	Medium	1300-1700	Optional Kit	
	High	1750-2200	Optional Kit	

## Blower RPM for XBWU20

### SUPPLY

		Mist Eliminator Filter in Intake Hood (2HP)						
		External Static Pressure (in water)						
		0	0.25	0.5	0.75	1	1.25	1.5
CFM	1200	1055	1135	1295	1420	1540	1650	1725
	1400	1140	1240	1340	1490	1600	1690	1795
	1600	1200	1330	1460	1565	1645	1740	1830
	1800	1320	1405	1525	1615	1705	1785	1885
	2000	1415	1515	1605	1690	1775	1875	1960

### EXHAUST

		Barometric Hood, 2" Pleated Filters (2HP)						
		External Static Pressure (in water)						
		0	0.25	0.5	0.75	1	1.25	1.5
CFM	1200	1010	1195	1350	1445	1580	1685	1735
	1400	1125	1315	1435	1545	1620	1730	1800
	1600	1185	1370	1500	1610	1695	1790	1965
	1800	1305	1485	1600	1685	1781	1955	2030
	2000	1410	1550	1670	1765	1855	N/A	N/A

Notes:

1. Drive losses included in the above tables.
2. Performance can vary depending on ambient conditions
3. Blower RPMs are for reference only

		RPM Range		
	Low	1000-1300	Standard Unit	
	Medium	1300-1700	Optional Kit	
	High	1700-2080	Optional Kit	

## Blower RPM for XBWU28

### SUPPLY



		Mist Eliminator Filter in Intake Hood (3HP)						
		External Static Pressure (in water)						
		0	0.25	0.5	0.75	1	1.25	1.5
CFM	1200	N/A	790	960	1110	1210	1315	1380
	1600	750	900	1005	1145	1230	1365	1410
	2000	900	1005	1105	1210	1275	1400	1450
	2400	1005	1125	1210	1275	1365	1450	1500
	2800	1125	1230	1315	1380	1450	1535	1600

### EXHAUST

		Barometric Hood, 2" Pleated Filters (3HP)						
		External Static Pressure (in water)						
		0	0.25	0.5	0.75	1	1.25	1.5
CFM	1200	750	885	1015	1145	1260	1350	1485
	1600	870	1015	1125	1215	1325	1410	1500
	2000	1015	1145	1240	1345	1410	1485	1560
	2400	1125	1250	1345	1430	1500	1575	1630
	2800	1250	1410	1485	1520	1630	1650	1675

Notes:

1. Drive losses included in the above tables.
2. Performance can vary depending on ambient conditions
3. Blower RPMs are for reference only

RPM Range		
	Low	750-975
	Medium	1008-1314
	High	1311-1708

Standard Unit  
Optional Kit  
Optional Kit

## Blower RPM for XBWU36

### SUPPLY



		Mist Eliminator Filter in Intake Hood (3HP)						
		External Static Pressure (in water)						
		0	0.25	0.5	0.75	1	1.25	1.5
CFM	2000	725	825	900	1000	1070	1180	1250
	2400	800	900	1000	1070	1160	1250	1275
	2800	900	1000	1070	1160	1250	1275	1340
	3200	1000	1070	1160	1250	1275	1340	1400
	3600	1055	1180	1250	1300	1360	N/A	N/A

### EXHAUST

		Barometric Hood, 2" Pleated Filters (3HP)						
		External Static Pressure (in water)						
		0	0.25	0.5	0.75	1	1.25	1.5
CFM	2000	750	865	950	1030	1100	1200	1265
	2400	820	950	1035	1100	1200	1265	1300
	2800	925	1035	1150	1200	1265	1315	1350
	3200	1035	1160	1215	1265	1325	1350	1390
	3600	1100	1215	1300	1350	1390	N/A	N/A

Notes:

1. Drive losses included in the above tables.
2. Performance can vary depending on ambient conditions
3. Blower RPMs are for reference only

RPM Range		
	Low	725-975
	Medium	1000-1315
	High	1215-1425

Standard Unit  
Optional Kit  
Optional Kit

## Blower RPM for XBWU46

### SUPPLY

		Mist Eliminator Filter in Intake Hood (5HP)						
		External Static Pressure (in water)						
		0	0.25	0.5	0.75	1	1.25	1.5
CFM	3000	900	1030	1100	1165	1240	1285	1350
	3400	975	1085	1175	1240	1290	1350	1400
	3800	1070	1175	1240	1290	1350	1400	1465
	4200	1165	1240	1320	1350	1430	1465	1515
	4600	1240	1320	1375	1430	1500	1515	1580

### EXHAUST

		Barometric Hood, 2" Pleated Filters (5HP)						
		External Static Pressure (in water)						
		0	0.25	0.5	0.75	1	1.25	1.5
CFM	3000	955	1100	1160	1245	1280	1360	1425
	3400	1055	1185	1245	1300	1375	1425	1480
	3800	1160	1300	1360	1400	1425	1530	1585
	4200	1245	1375	1450	1480	1500	1585	1650
	4600	1360	1450	1500	1585	1600	1650	1700

Notes:

1. Drive losses included in the above tables.
2. Performance can vary depending on ambient conditions
3. Blower RPMs are for reference only

		RPM Range		
	Low	780-1020	Standard Unit	
	Medium	1000-1315	Optional Kit	
	High	1315-1700	Optional Kit	

## Blower RPM for XBWU62

### SUPPLY

		Mist Eliminator Filter in Intake Hood (5HP)						
		External Static Pressure (in water)						
		0	0.25	0.5	0.75	1	1.25	1.5
CFM	4600	815	900	975	1045	1085	1125	1175
	5000	880	940	1015	1060	1135	1175	1215
	5400	915	975	1045	1125	1150	1195	1250
	5800	975	1045	1085	1175	1250	1260	N/A
	6200	1000	1075	1165	1200	N/A	N/A	N/A

### EXHAUST

		Barometric Hood, 2" Pleated Filters (5HP)						
		External Static Pressure (in water)						
		0	0.25	0.5	0.75	1	1.25	1.5
CFM	4600	825	915	1000	1025	1100	1140	1170
	5000	890	975	1025	1100	1140	1170	1240
	5400	925	1000	1085	1140	1170	1240	1280
	5800	975	1025	1140	1170	1240	N/A	N/A
	6200	1025	1120	1170	N/A	N/A	N/A	N/A

Notes:

1. Drive losses included in the above tables.
2. Performance can vary depending on ambient conditions
3. Blower RPMs are for reference only

		RPM Range		
	Low	820-1000	Standard Unit	
	Medium	1000-1200	Optional Kit	
	High	1175-1375	Optional Kit	

# START UP INFORMATION SHEET

## VOLTAGE - ERV UNIT

Incoming Voltage L1-L2 \_\_\_\_\_ L1-L3 \_\_\_\_\_ L2-L3 \_\_\_\_\_  
Running Voltage L1-L2 \_\_\_\_\_ L 1-L3 \_\_\_\_\_ L2-L3 \_\_\_\_\_  
Secondary Voltage \_\_\_\_\_ C (black) to G (green) Volts\* \_\_\_\_\_  
C (black) to W (white) Volts\* \_\_\_\_\_

\* With thermostat calling.

## AMPERAGE - ERV MOTORS

Intake Motor: Nominal HP \_\_\_\_\_ Rated Amps \_\_\_\_\_ Running Amps \_\_\_\_\_  
Exhaust Motor: Nominal HP \_\_\_\_\_ Rated Amps \_\_\_\_\_ Running Amps \_\_\_\_\_  
Wheel Motor: Nominal HP \_\_\_\_\_ Rated Amps \_\_\_\_\_ Running Amps \_\_\_\_\_

## AIRFLOW

Intake Design CFM \_\_\_\_\_ Pressure Drop \_\_\_\_\_ Calculated CFM \_\_\_\_\_  
Exhaust Design CFM \_\_\_\_\_ Pressure Drop \_\_\_\_\_ Calculated CFM \_\_\_\_\_  
Amb. db Temp \_\_\_\_\_ Return Air db Temp\* \_\_\_\_\_ Tempered Air db Temp\* \_\_\_\_\_  
Amb. wb Temp \_\_\_\_\_ Return Air wb Temp\* \_\_\_\_\_ Tempered Air wbTemp\* \_\_\_\_\_

\* Measure after 15 minutes of run time

## INSTALLATION CHECK LIST

ERV Model # \_\_\_\_\_ Serial # \_\_\_\_\_  
Owner \_\_\_\_\_ Owner Phone # \_\_\_\_\_  
Owner Address \_\_\_\_\_  
Installing Contractor \_\_\_\_\_ Start Up Mechanic \_\_\_\_\_

- Inspect the unit for transit damage and report any damage on the carrier's freight bill.
- Check model number to insure it matches the job requirements.
- Install field accessories and unit adapter panels as required. Follow accessory and unit installation manuals.
- Verify field wiring, including the wiring to any accessories.
- Check all multi-tap transformers, to insure they are set to the proper incoming voltage.
- Verify correct belt tension, as well as the belt/pulley alignment. Tighten if needed.
- Prior to energizing the unit, inspect all the electrical connections.
- Power the unit. Bump the motor contactor to check rotation. Three phase motors are synchronized at the factory. If blower motor fans are running backwards, de-energize power to the unit, then swap two of the three incoming electrical lines to obtain proper phasing. Re-check.
- Perform all start up procedures outlined in the installation manual shipped with the unit.
- Fill in the Start Up Information as outlined on the opposite side of this sheet.
- Provide owner with information packet. Explain the thermostat and unit operation.

# REZNOR®

1-800-695-1901; [www.ReznorHVAC.com](http://www.ReznorHVAC.com)

©2014 Reznor, LLC. All rights reserved. Printed in U.S.A.  
Reznor® is registered in at least the United States.  
All other marks are the property of their respective organizations.